

019-1.5" INTERMEDIATE PIVOT, 1 -1/2" OFFSET, HANDED

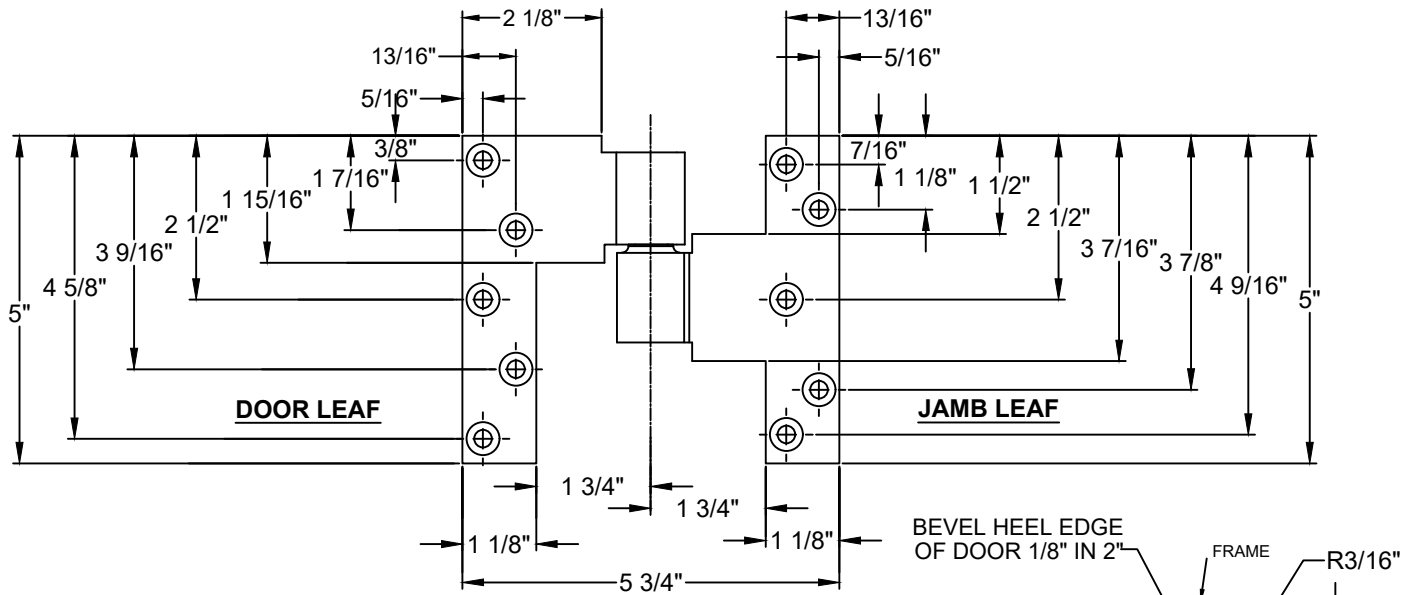

NOTES:

1. PIVOTS DRILLED FOR 1/4-20 x 3/4" FHMS OR #14 x 2" FHWS.
2. REINFORCING BY OTHERS.
3. IT IS THE DOOR AND FRAME MANUFACTURERS RESPONSIBILITY TO CHECK THE HARDWARE SCHEDULE AND PREP THE DOORS AND FRAMES.
4. MAXIMUM DEGREE OF OPENING, 180°, TRIM PERMITTING.
5. RIGHT HAND SHOWN.

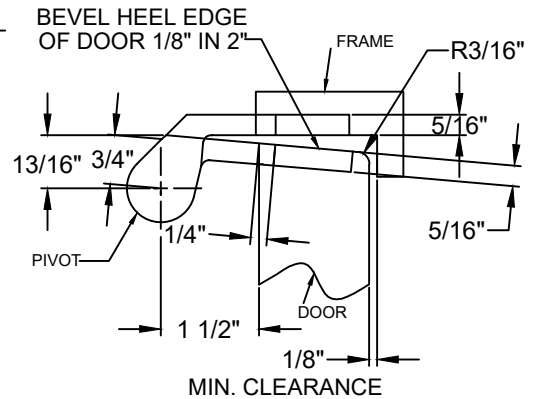

TOP VIEW

INSTALLATION INSTRUCTIONS

NOTE: DOOR SHOULD ALREADY BE HUNG WITH TOP PIVOT AND BOTTOM PIVOT (OR FLOOR CLOSER).

1. MORTISE DOOR & FRAME PER TEMPLATE ABOVE.
2. INSTALL 019-1.5" DOOR & FRAME PIVOT LEAVES.
3. ALIGN PIVOT POINT FROM TOP PIVOT TO BOTTOM ARM (SEE DRAWING).
4. REMOVE 019 END CAP.
5. TURN 019 RETAINER SCREW CLOCKWISE TO RAISE THE DOOR OR COUNTERCLOCKWISE TO LOWER DOOR UNTIL YOU REACH THE DESIRED HEIGHT.
6. TURN 019 RETAINER SCREW .
7. TIGHTEN 019 RETAINER SCREW UNTIL YOU FEEL RESISTANCE.
8. REPLACE 019 END CAP.

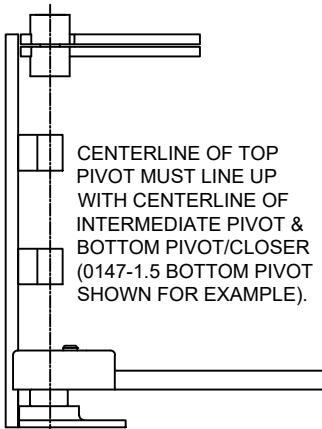

CENTERLINE OF TOP PIVOT MUST LINE UP WITH CENTERLINE OF INTERMEDIATE PIVOT & BOTTOM PIVOT/CLOSER (0147-1.5 BOTTOM PIVOT SHOWN FOR EXAMPLE).

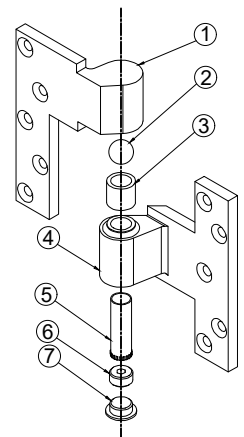

ITEM NO.	QTY.	PART NO.
1	1	019-1.5" Door Leaf
2	1	019 Alignment Ball
3	1	019 Needle Bearing
4	1	019-1.5" Jamb Leaf
5	1	019 Pivot Pin
6	1	019 Retainer Screw
7	1	019 End Cap

Disclaimer: This template is to be used for installation, as shown, of said product and is not suitable for every application method. Custom applications, where door sizes, weights and conflicting hardware are a factor, need to be addressed with ABH and proper instructions provided. ABH is not liable for failure or performance of the product due to improper installation methods and/or use. Improper use and/or installation of this product will void the standard warranty.