

0370 PIVOT SET, CENTER HUNG, NON-HANDED

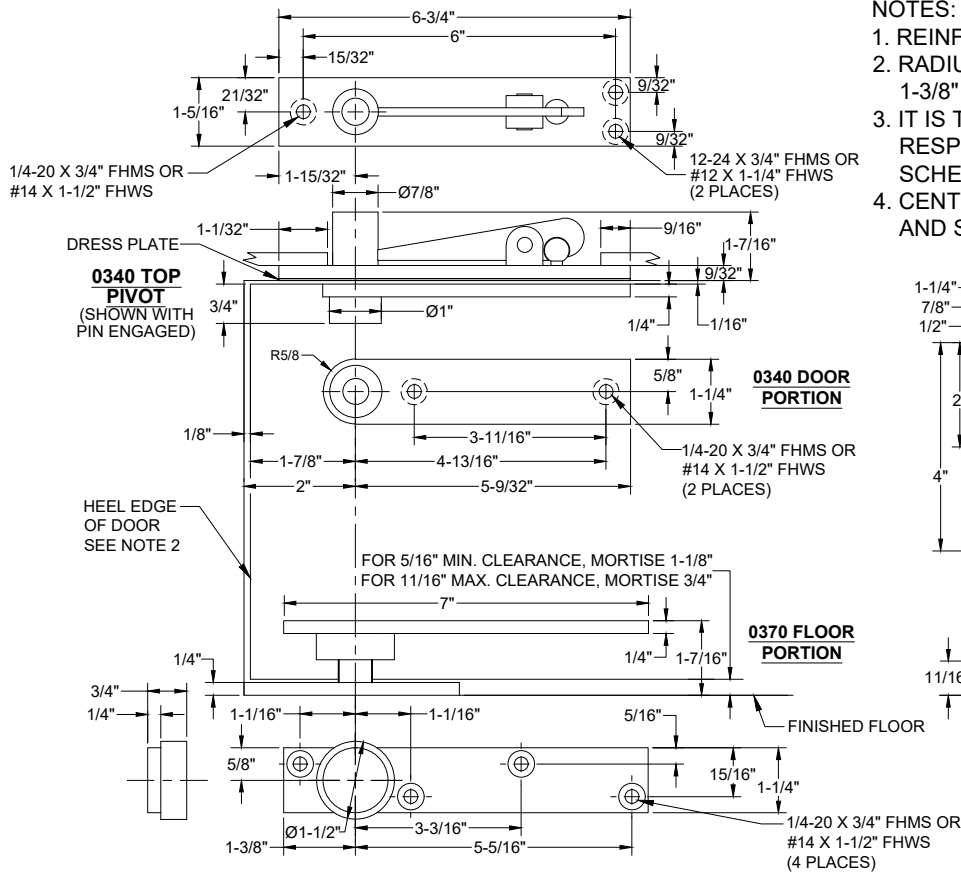

NOTES:

1. REINFORCING BY OTHERS.
2. RADIUS HEEL EDGE OF DOOR 1-7/8" MAX FOR 1-3/8" TO 2-1/2" THICK DOORS.
3. IT IS THE DOOR AND FRAME MANUFACTURERS RESPONSIBILITY TO CHECK THE HARDWARE SCHEDULE AND PREP THE DOORS AND FRAMES.
4. CENTERLINE OF TOP PIVOT PIN MUST BE PLUMB AND STRAIGHT WITH BOTTOM PIVOT.

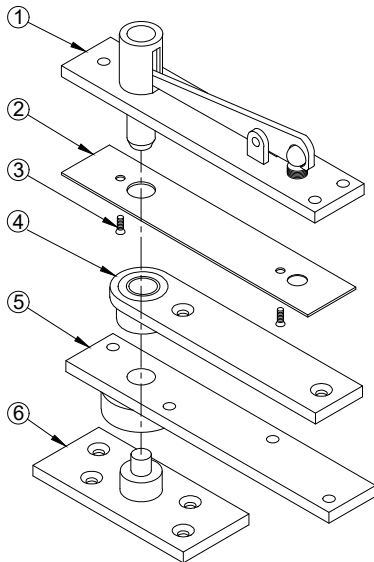
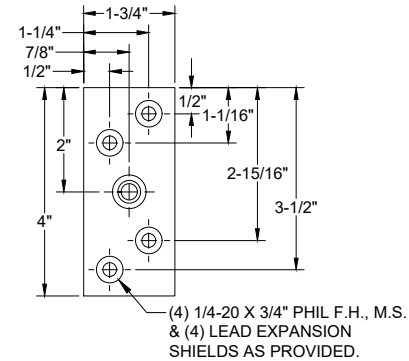

ITEM NO.	QTY.	PART NO.
1	1	0340 JAMB PORTION
2	1	0340 DRESS PLATE
3	2	0340 DRESS PLATE SCREW
4	1	0340 DOOR PORTION
5	1	0370 DOOR PORTION
6	1	0370 FLOOR PORTION

INSTALLATION INSTRUCTIONS

1. MEASURE 2" OUT FROM DOOR JAMB ON CENTERLINE OF DOOR. THIS IS THE LOCATION OF SPINDLE CENTER.
2. RADIUS HINGE EDGE AND PREPARE DOOR FOR 1/16" MIN. CLEARANCE THRU ENTIRE OPENING.
3. INSTALL 0370 DOOR PORTION PER TEMPLATE.
4. INSTALL 0370 FLOOR PORTION PER TEMPLATE.
5. INSTALL 0340 DOOR PORTION PER TEMPLATE.
6. INSTALL 0340 JAMB PORTION PER TEMPLATE.
7. FASTEN 0340 DRESS PLATE TO 0340 JAMB PORTION.
8. CENTERLINE OF PIVOT SHOULD ALIGN WITH CENTERLINE OF BOTTOM SPINDLE. USE A PLUMB LINE TO ASSURE ACCURACY.
9. SET INSTALLED 0370 DOOR PORTION ON 0370 FLOOR PORTION SPINDLE.
10. ENGAGE THE TOP PIVOT PIN BY TURNING PIN RETRACTING SCREW CLOCKWISE.

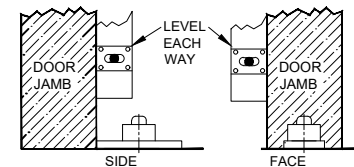
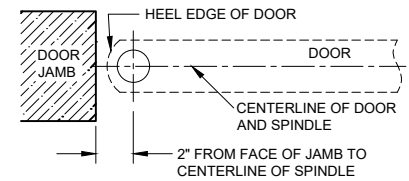

DISMOUNT DOOR (IF REQUIRED)

1. OPEN THE DOOR ENOUGH TO DISENGAGE THE TOP PIVOT.
2. ROTATE THE DOOR TO CLOSED POSITION.
3. WITH THE TOP OF THE DOOR LEANING TOWARD YOU, LIFT THE DOOR CLEAR OF THE SPINDLE.

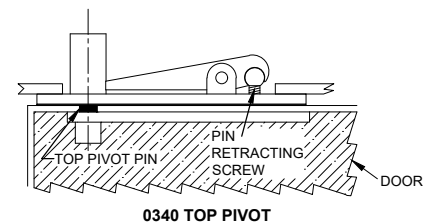

Disclaimer: This template is to be used for installation, as shown, of said product and is not suitable for every application method. Custom applications, where door sizes, weights and conflicting hardware are a factor, need to be addressed with ABH and proper instructions provided. ABH is not liable for failure or performance of the product due to improper installation methods and/or use. Improper use and/or installation of this product will void the standard warranty.