

SARGENT 3520 SERIES POWER SUPPLIES OPERATION AND INSTALLATION INSTRUCTIONS

MODELS: 3520 (24 VOLT); 3521 (12 VOLT) SUPPLIES;
AND 737-12 VOLT AND 738-24 VOLT BATTERY BACKUP KITS

SARGENT®

ASSA ABLOY

DESCRIPTION

SARGENT Model 3521 is a 12-volt, 1-amp* power supply delivered in a single lockable enclosure with the line voltage connections made by screw terminals. Model 3520 is the same unit with 24-volt, 1-amp output. All units feature regulated, adjustable power with integral sealed lead acid/gel cell battery charging capability. All units also meet Class 2 electrical requirements, which means under the National Electrical Code that output wiring does not need to be in conduit; however, compliance with applicable wiring codes should always be checked with the local building department before installing these units.

WARNING: The power supply must only be opened by trained service personnel when the cover LED is on.

SAFETY

Two hazards are present in the Sargent 3520 series supply:

- Line voltage input presents a high voltage shock hazard.
- Battery output presents a high energy hazard. If shorted, the battery output can generate sufficient heat to ignite some materials.

To insure safety, the cover LED should be on whenever the supply offers danger, which is either if it is receiving line voltage or if batteries are operating.

OPERATING CHARACTERISTICS

Line Voltage Input

110–120 VAC should be input to terminals **H**, **N**, **G**, as shown in Figure 1. Wiring for Model 3521 and Model 3520. The line voltage current drawn by the power supply module will be approximately 500 mA.

DC OUTPUT AND VOLTAGE ADJUSTMENT

The power supply DC capacity depends on the exact voltage that is set and on whether or not batteries are employed. The power supplies can output 1 amp* when set at precisely 12 or 24 VDC. However, it is recommended that the power supplies not be operated at maximum capacity. This reduces the possibility of heat-induced failure and also allows for later installation expansion. When the power supply is used with batteries, available current capacity is reduced. This is because the voltage must be set higher to 13.5 or 27 volts (factory set values) and also because some current is used to charge the batteries. Model 3521 output range is 11.1–13.5 VDC and Model 3520 output range is 23.0–27.0 VDC.

* For UL listed applications, DC output current shall not exceed 650 mA when batteries are not used. For UL applications where batteries are used, the total output shall not exceed 1 amp (650 mA DC output + 350 mA battery charging current).

SARGENT 3520 SERIES POWER SUPPLIES OPERATION AND INSTALLATION INSTRUCTIONS

MODELS: 3520 (24 VOLT); 3521 (12 VOLT) SUPPLIES;
AND 737-12 VOLT AND 738-24 VOLT BATTERY BACKUP KITS

SARGENT®

ASSA ABLOY

Model 3521

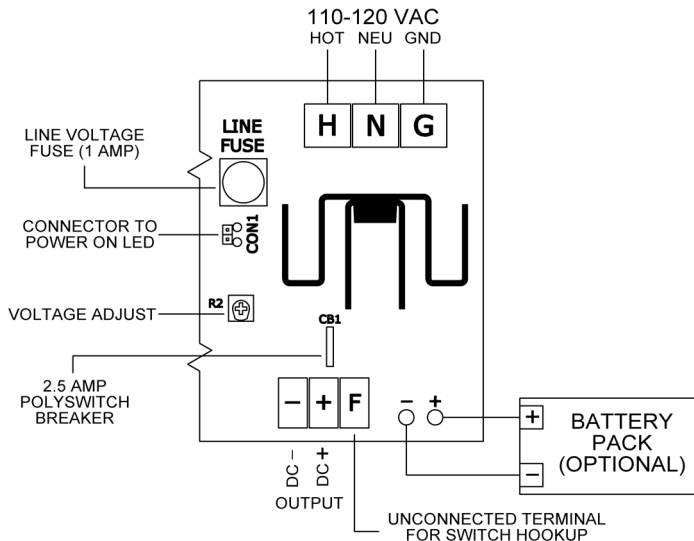

Model 3520

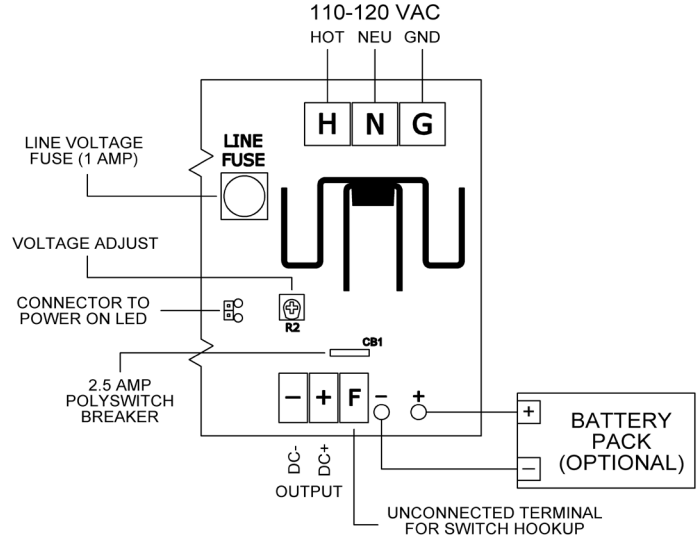

Figure 1. Wiring for Model 3521 and Model 3520

Battery Charging Capability

The Model 3521 and Model 3520 power supply incorporates a battery charging circuit appropriate for standby-rated sealed lead acid or gel cell batteries. Batteries are an option; the power supply can be used with or without them. A battery pack of the appropriate voltage (see Table 1 Battery Pack Selection) is connected to the red and black battery leads following correct polarity. The batteries will be kept charged at all times by the power supply acting in concert with the components on the power supply board. In the event of a line voltage power failure, the batteries automatically drive the load; however, if the emergency release terminals are opened, battery power will be cut off.

No matter whether the unit is 12 or 24 volts, battery charging is available for battery packs up to 20 amp hours in capacity. Certain long backup times are not achievable with the maximum size battery packs (N/A appears in Table 1). Table 1 should be consulted to calculate the correct battery pack based on desired backup time and the current drawn. For proper battery charging, the power supply must be set at 27 volts for a 24-volt system, and at 13.5 volts for a 12-volt system. If the power supply is not set as such, the batteries will not hold full capacity or have normal operating life, and may be damaged.

Copyright © 2009, Sargent Manufacturing Company, an ASSA ABLOY Group company. All rights reserved. Reproductions in whole or in part without express written permission of Sargent Manufacturing Company is prohibited.

SARGENT 3520 SERIES POWER SUPPLIES OPERATION AND INSTALLATION INSTRUCTIONS

MODELS: 3520 (24 VOLT); 3521 (12 VOLT) SUPPLIES;
AND 737-12 VOLT AND 738-24 VOLT BATTERY BACKUP KITS

SARGENT®

ASSA ABLOY

CURRENT DRAW	BACKUP TIME DESIRED									
	Min	1 HR	2 HRs	4 HRs	UL Std	8 HRs	16 HRs	24 HRs	48 HRs	72 HRs
150 mA	4 AH	4 AH	4 AH	4 AH	4 AH	4 AH	4 AH	8 AH	8 AH	12 AH
300 mA	4 AH	4 AH	4 AH	4 AH	4 AH	4 AH	8 AH	12 AH	16 AH	N/A
500 mA	4 AH	4 AH	4 AH	4 AH	4 AH	8 AH	12 AH	16 AH	N/A	N/A
750 mA	4 AH	4 AH	4 AH	8 AH	12 AH	12 AH	16 AH	20 AH	N/A	N/A
Min: Refers to a facility using an emergency generator, where the batteries are only required to operate the system for under 3 minutes until takeover by the generator.										
UL Std: Requires 4 hours of battery operation followed by a 24-hour recharge period and then a second 4 hours of operation.										
Notes: 1. Batteries must be sealed lead acid or gel cell type. Dry cells will not recharge and will be damaged. 2. The above table is only valid if batteries are operated at room temperature. Capacity is reduced in cold environment. 3. Batteries should be replaced after five (5) years of use.										

Table 1. Battery Pack Selection

Circuit Polyswitches and Fusing

The SARGENT 3520 series has a 1-amp AC fuse on the board along with a 2.5-amp DC Polyswitch. The AC fuse is located on the hot 120 VAC input and protects against a transformer internal short. A short in the DC load will not blow the AC fuse as the power supply is short-circuit protected and will shut off if there is an attempt to draw more than its rated output. A DC short cannot damage the power supply, but will cause problems as the load will be shut off. Additionally if batteries are used, they will switch into the short when the power supply shuts down and will supply a tremendous amount of current into a short, which could easily melt wire insulation. To protect against a short circuit when batteries are being employed, a 2.5-amp DC Polyswitch breaker is provided. The Polyswitch, functioning as an automatic circuit breaker, receives an overload and rapidly cuts the current down to a small leakage current (about 100 mA).

EXAMPLE: If a short circuit appeared, tripped the Polyswitch and the short was corrected, but the wire from the – terminal was not disconnected, the Polyswitch would see the normal load and would continue to block current flow until reset.

The reset procedure is as follows:

REMOVE all current from the Polyswitch for a period of ten (10) seconds by disconnecting the wire from the + or – terminal.

SARGENT 3520 SERIES POWER SUPPLIES OPERATION AND INSTALLATION INSTRUCTIONS

MODELS: 3520 (24 VOLT); 3521 (12 VOLT) SUPPLIES;
AND 737-12 VOLT AND 738-24 VOLT BATTERY BACKUP KITS

SARGENT®

ASSA ABLOY

Emergency Release

Emergency release of power supply DC output is easily accomplished by using the unconnected **F** terminal. The NC contacts of the release switch are connected between **+** and **F** (see Figure 2, Adding Switch for Emergency Release) and then a load is connected to **-** and **F**. When the emergency release contacts open, all DC power will be cut off. When the connection is to a UL-listed fire alarm system, the auxiliary latching normally closed contacts are used. Do not use trouble contacts.

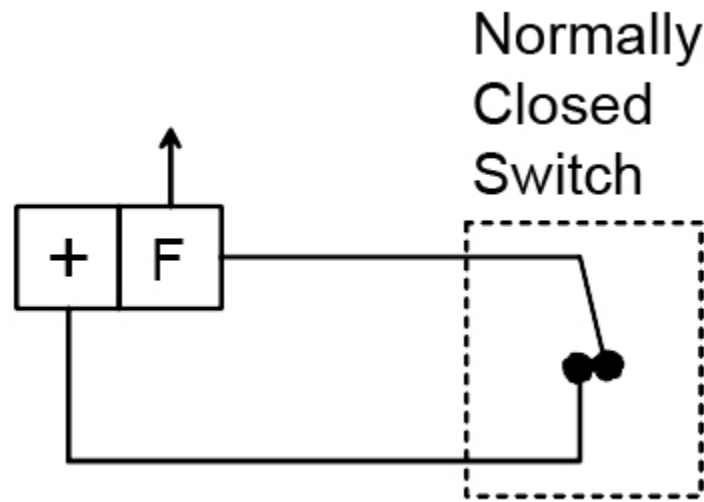

Figure 2. Adding Switch for Emergency Release

IMPORTANT: This product must be installed according to all applicable building and life safety codes.

INSTALLATION

1. ENSURE during product installation with circuit conductors operating at 150 volts or less to ground, that a minimum ¼ inch (6.4 mm) separation is provided between all Class 2 or 3 cable conductors extending beyond the jacket and all electric light, power, Class 1 conductors, non-Class 2 or 3 signaling conductors and medium-power network-powered broadband communications-circuit conductors.

WARRANTY

The Model 3521 and Model 3520 are covered by the Sargent lifetime replacement no fault warranty. No registration is required. Product will be replaced forever, for any reason, including but not limited to installation error, vandalism, or act of God. Replacement product is shipped at Sargent's expense next day air, if needed.

For more information visit www.SargentLock.com.