

4400RA ADJUSTABLE SERIES HOLDERS & STOPS

SURFACE MOUNT, DOOR THICKNESS 1-3/4" TO 2-1/4"

- 4410RA HOLD-OPEN
- 4420RA STOP
- 4430RA FRICTION

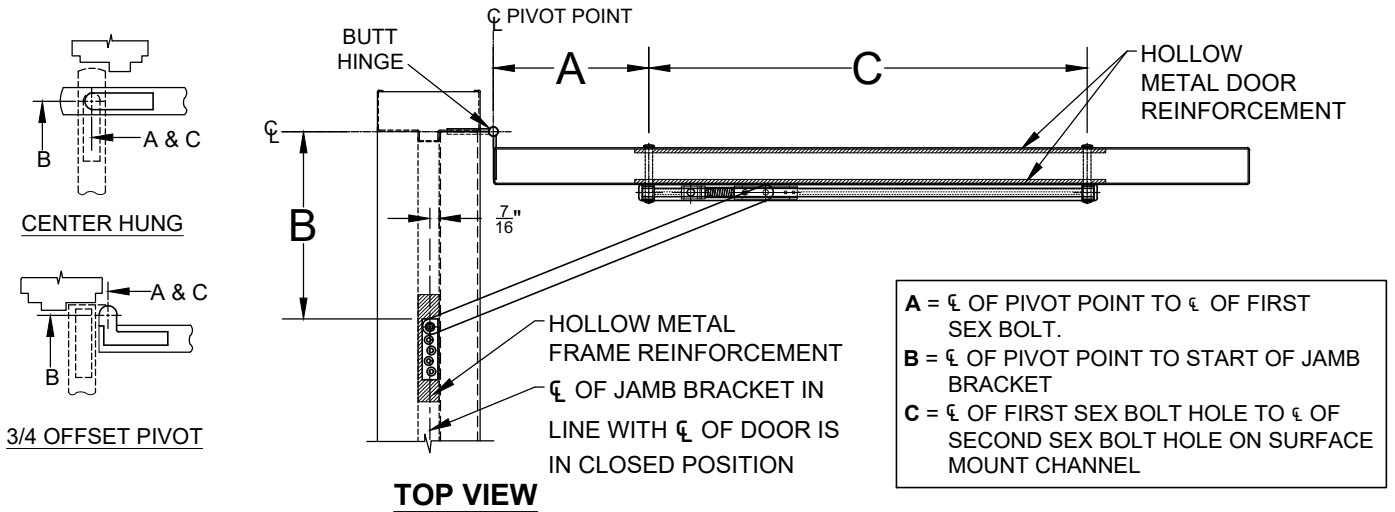

TOP VIEW

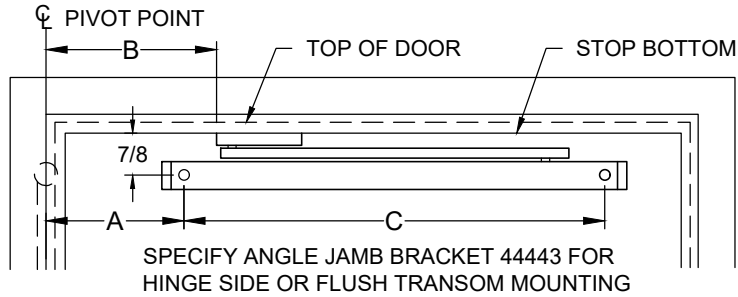

FRONT VIEW
PUSH SIDE OF DOOR

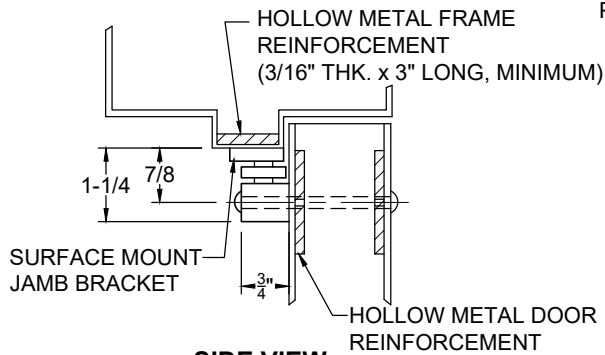

SIDE VIEW
CROSS SECTION

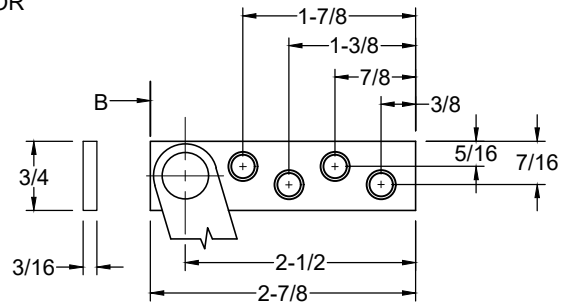

JAMB BRACKET

SCREW DETAIL			
	QTY	WOOD	METAL
JAMB	4	• #10 x 1-1/2" FLAT HEAD WOOD SCREW	• 10-32 x 1/2" FLAT HEAD MACHINE SCREW
DOOR	2	• 10-32 x 1-1/2" TRUSS HEAD MACHINE SCREW	
	2	• 5/16" DIA. SEX BOLT	

NOTES:

1. REVERSIBLE, NON - HANDED
2. FOR SINGLE ACTING DOORS ONLY
3. ALL DRILLING & TAPPING TO BE DONE IN FIELD.
4. ALWAYS REQUEST LATEST TEMPLATE/ DRAWING FOR NEW INSTALLATIONS.
5. ALL DIMENSIONS ARE IN INCHES, UNLESS NOTED.
6. DRAWING IS NOT TO SCALE

4400RA-1-00.DWG



www.abhmfg.com
 E-mail: abhinfo@abhmfg.com
 Architectural Builders Hardware Mfg., Inc.
 1222 Ardmore Ave., Itasca, IL 60143
 630.875.9900; FAX 800.9FAXABH (932.9224)

© 2021 ABH Mfg., Inc.
 printed in USA

4400RA

PAGE 1 OF 2
 ISSUED 05-03-21

4400RA ADJUSTABLE SERIES HOLDERS & STOPS

SURFACE MOUNT, DOOR THICKNESS 1-3/4" TO 2-1/4" , REVERSIBLE, NON-HANDED

- 4410RA HOLD-OPEN
- 4420RA STOP
- 4430RA FRICTION

1. ADD 5/8" TO "A" DIMENSION FOR DEAD STOP.
2. ALL DIMENSIONS ARE IN INCHES.

WHEN USING CENTER HUNG PIVOTS, CHECK PIVOT MANUFACTURER'S COMPATIBILITY PRIOR TO SPECIFYING

BUTT HINGE & 3/4" OFFSET PIVOT						
MODEL NUMBER			* BUTT HINGE MOUNTING ONLY			
HOLD OPEN	STOP	FRICTION	FRAME OPENING	A	B	C
* 4411RA	* 4421RA	* 4431RA	* 18 TO 24	* 1-3/16	* 3-7/8	14-13/16
4412RA	4422RA	4432RA	24-1/16 TO 30	4-1/4	4-5/8	16
4413RA	4423RA	4433RA	30-1/16 TO 36	6-3/16	5-3/8	17-3/4
4414RA	4424RA	4434RA	36-1/16 TO 42	9-3/8	7-1/8	20-3/16
4415RA	4425RA	4435RA	42-1/16 TO 48	13-5/8	7-1/2	22

CENTER HUNG						
MODEL NUMBER						
HOLD OPEN	STOP	FRICTION	FRAME OPENING	A	B	C
4411RA	4421RA	4431RA	21 TO 26-1/2	1-3/4	4-5/8	14-13/16
4412RA	4422RA	4432RA	26-9/16 TO 32	5-3/4	4-5/16	16
4413RA	4423RA	4433RA	32-1/16 TO 38	6-15/16	6-1/8	17-3/4
4414RA	4424RA	4434RA	38-1/16 TO 45	10-1/16	7-13/16	20-3/16
4415RA	4425RA	4435RA	45-1/16 TO 48	14	8-13/16	22

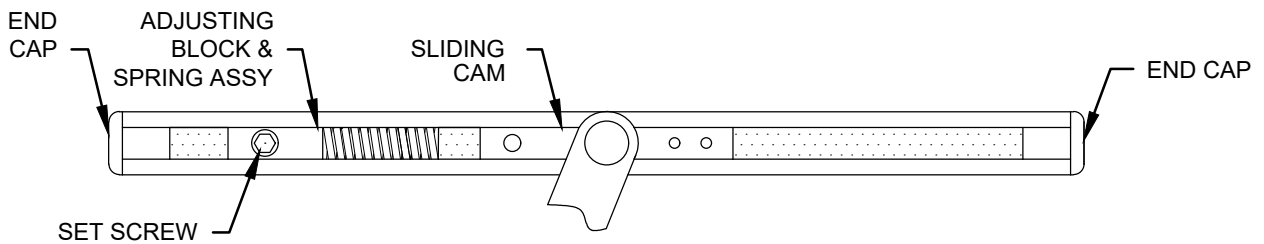

TO SELECT MAX. DEGREE (up to 110°) OF DOOR OPENING

- a. LOOSEN SET SCREW IN ADJUSTING BLOCK WITH 3/16 HEX KEY
- b. OPEN DOOR TO DEGREE REQUIRED
- c. SLIDE ADJUSTING BLOCK/SPRING ASSEMBLY UNTIL THE SPRING TOUCHES SLIDING CAM.
- d. TIGHTEN SET SCREW
- e. **110° MAX.** DOOR SWING

4400RA-2-00.DWG



www.abhmfg.com
 E-mail: abhinfo@abhmfg.com
 Architectural Builders Hardware Mfg., Inc.
 1222 Ardmore Ave., Itasca, IL 60143
 630.875.9900; FAX 800.9FAXABH (932.9224)

© 2021 ABH Mfg., Inc.
 printed in USA

4400RA

PAGE 2 OF 2
 ISSUED 05-03-21