

RM441CU DOME STOP COMBINATION UNIT

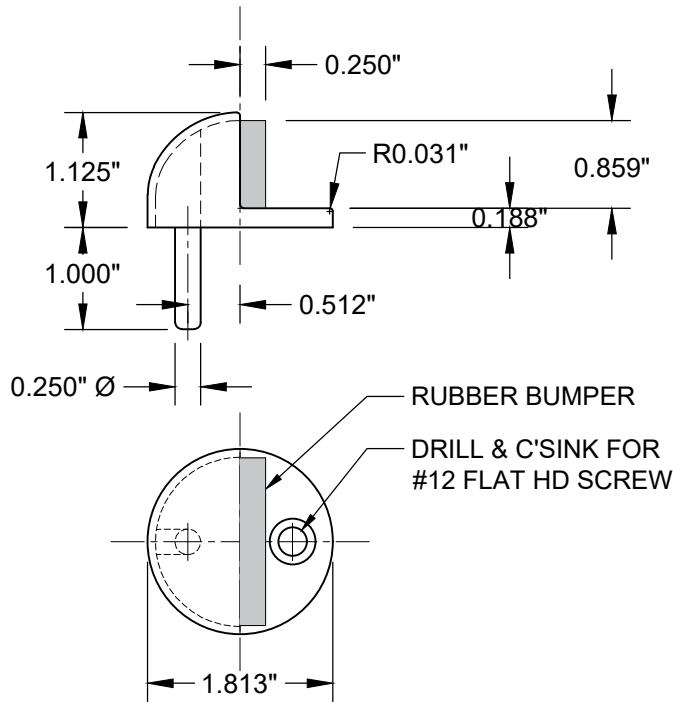

RM441 - DOME STOP BASE

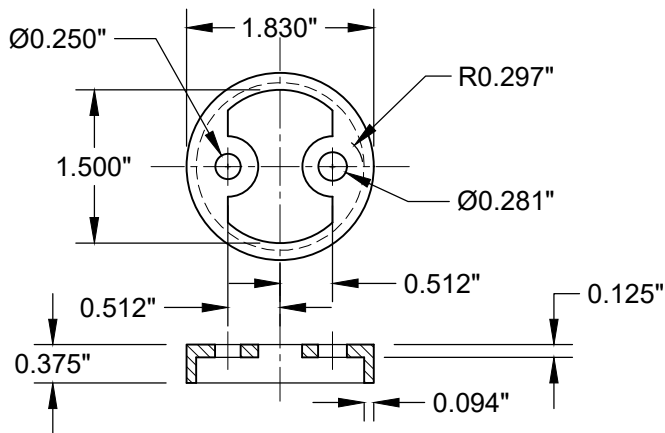
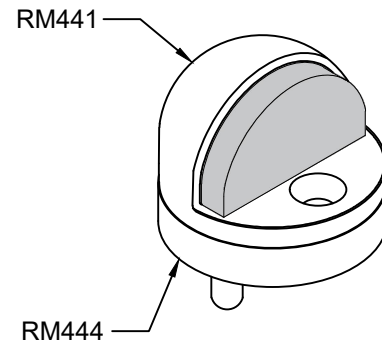

RM444 - RISER BASE

NOTES:

1. ALL DIMENSIONS ARE IN INCHES
2. DO NOT SCALE DRAWING
3. SET CONSIST OF DOME STOP & RISER BASE.
4. FOR USE AT DOORS WITH or WITHOUT THRESHOLD.
5. CONVERTIBLE FOR UNDERCUT OR NOT UNDERCUT DOORS.
6. #12x1-1/2"/12-24x1-1/2" FLAT HEAD WOOD/MACHINE SCREW(1 PLACE)

RM 441CU-00 DOME STOP.DWG



www.abhmfg.com
 E-mail: abhinfo@abhmfg.com
 Architectural Builders Hardware Mfg., Inc.
 1222 Ardmore Ave., Itasca, IL 60143
 630.875.9900; FAX 800.9FAXABH (932.9224)

© 2021 ABH Mfg., Inc.
 printed in USA

RM441CU

PAGE 1 OF 1
 ISSUED 06-09-21