

57- 59-

**80 Series
Exit Device
PCB Module Assembly
Installation Instructions**

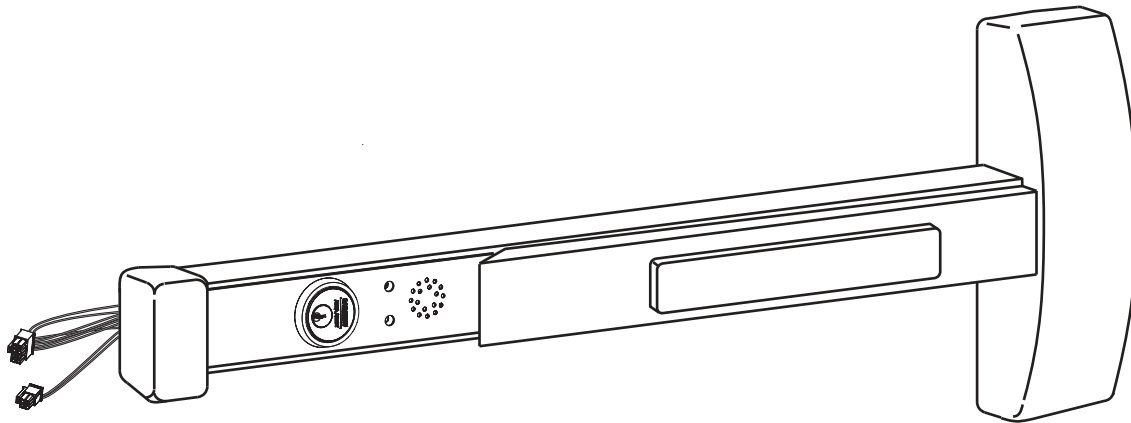

For installation assistance, contact SARGENT at 800-810-WIRE (9473)

Table of Contents

1	Warning.....	4
2	Replacement Instructions.....	5
3	57- Troubleshooting.....	8
4	59- Troubleshooting.....	11



ElectroLynx®

As part of their promise to provide innovative, fast and effective, and higher security solutions to their customers, ASSA ABLOY Group companies offer ElectroLynx, a universal quick-connect system that simplifies the electrification of the door opening.

ElectroLynx® is a registered trademark of ASSA ABLOY, Inc.

1 Warning

Changes or modifications to this device not expressly approved by ASSA ABLOY could void the user's authority to operate the equipment.

FCC:

This equipment has been tested and found to comply with the limits for a Class B digital device, pursuant to Part 15 of the FCC Rules. These limits are designed to provide reasonable protection against harmful interference in a residential installation. This equipment generates, uses, and can radiate radio frequency energy and, if not installed and used in accordance with the instructions, may cause harmful interference to radio communications. However, there is no guarantee that interference will not occur in a particular installation. If this equipment does cause harmful interference to radio or television reception, which can be determined by turning the equipment off and on, the user is encouraged to try to correct the interference by one or more of the following measures:

- Reorient or relocate the receiving antenna.
- Increase the separation between the equipment and receiver.
- Connect the equipment into an outlet on a circuit different from that to which the receiver is connected.
- Consult the dealer or an experienced radio/TV technician for help.

Industry Canada:

This Class B digital apparatus meets all requirements of the Canadian Interference Causing Equipment Regulations. Operation is subject to the following two conditions: (1) this device may not cause harmful interference, and (2) this device must accept any interference received, including interference that may cause undesired operation.

Cet appareillage numérique de la classe B répond à toutes les exigences de l'interférence canadienne causant des règlements d'équipement. L'opération est sujette aux deux conditions suivantes: (1) ce dispositif peut ne pas causer l'interférence nocive, et (2) ce dispositif doit accepter n'importe quelle interférence reçue, y compris l'interférence qui peut causer l'opération peu désirée.

"This equipment complies with FCC radiation exposure limits set forth for an uncontrolled environment. This equipment should be installed and operated with minimum distance 20cm between the radiator and your body. This transmitter must not be co-located or operating in conjunction with any other antenna or transmitter."

Under Industry Canada regulations, this radio transmitter may only operate using an antenna of a type and maximum (or lesser) gain approved for the transmitter by Industry Canada. To reduce potential radio interference to other users, the antenna type and its gain should be so chosen that the equivalent isotropically radiated power (e.i.r.p.) is not more than that necessary for successful communication.

Conformément à la réglementation d'Industrie Canada, le présent émetteur radio peut fonctionner avec une antenne d'un type et d'un gain maximal (ou inférieur) approuvé pour l'émetteur par Industrie Canada. Dans le but de réduire les risques de brouillage radioélectrique à l'intention des autres utilisateurs, il faut choisir le type d'antenne et son gain de sorte que la puissance isotrope rayonnée équivalente (p.i.r.e.) ne dépasse pas l'intensité nécessaire à l'établissement d'une communication satisfaisante.

 Any retrofit or other field modification to a fire rated opening can potentially impact the fire rating of the opening, and SARGENT Manufacturing makes no representations or warranties concerning what such impact may be in any specific situation. When retrofitting any portion of an existing fire rated opening, or specifying and installing a new fire-rated opening, please consult with a code specialist or local code official (Authority Having Jurisdiction) to ensure compliance with all applicable codes and ratings.

2 Replacement Instructions

Prefix	Part Number	Description PCB Module Assembly Replacement
59-	52-4837	Standard
59- BC-	52-4838	BOCA (30 seconds)
57-	52-4830	Standard
57- BC-	52-4831	BOCA (30 seconds)

NOTE: Use caution when removing insert assembly to avoid damaging the rail harness connected to the PCB module assembly.

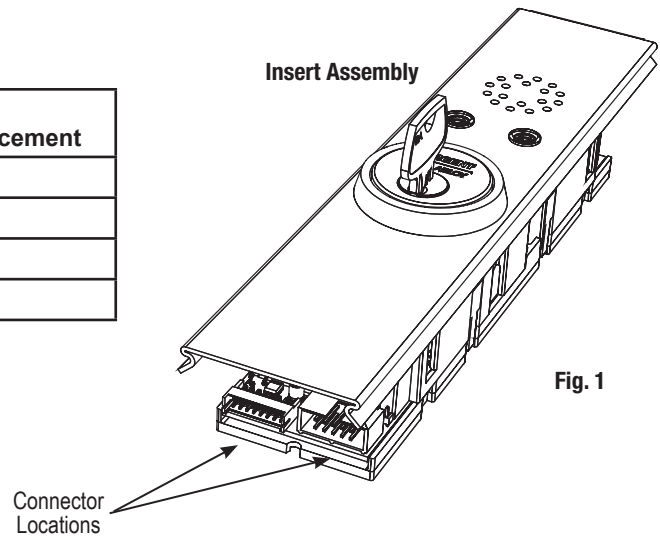

1. Ensure power to device is disconnected.
2. Carefully disconnect all connectors (Fig. 1).
3. Remove insert assembly from rail mounting assembly.
4. Loosen set screw by turning counter-clockwise using 5/64" allen wrench.
5. Extract and slide cylinder through spring and collar.

When replacing cylinder, slide cylinder through spring then collar, taking care to orient cylinder as shown.

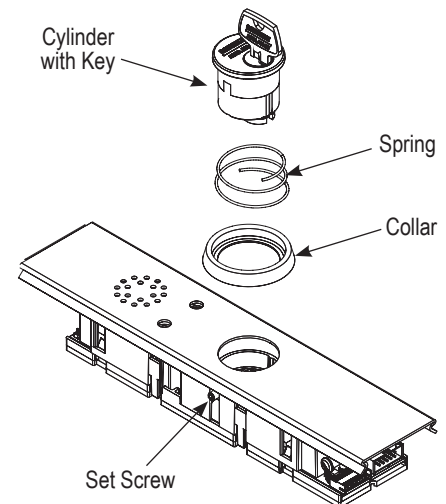

Cylinder Orientation

See illustration on circuit board for correct orientation of cylinder/cam when installing. Note that proper position of cam allows for removal of key.

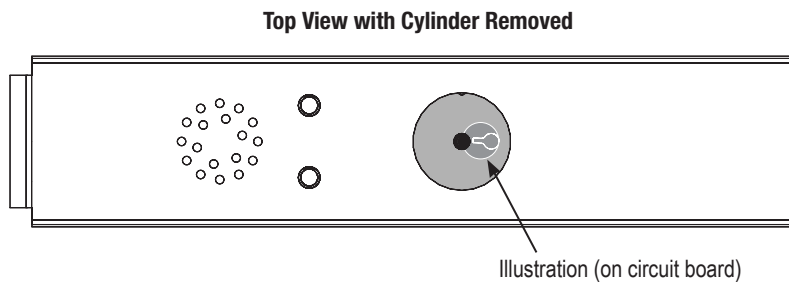

Top of Cylinder

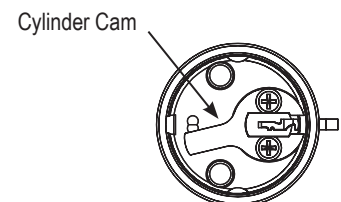

Bottom of Cylinder

2 Replacement Instructions (Continued)

NOTES:

With Rim, Mortise and Vertical Rod Exit Devices:

When jumper is missing or in wrong position, the Yellow Diagnostic LED turns ON. To locate (J5) jumper, remove Insert Assembly and Insert Assembly Plate:

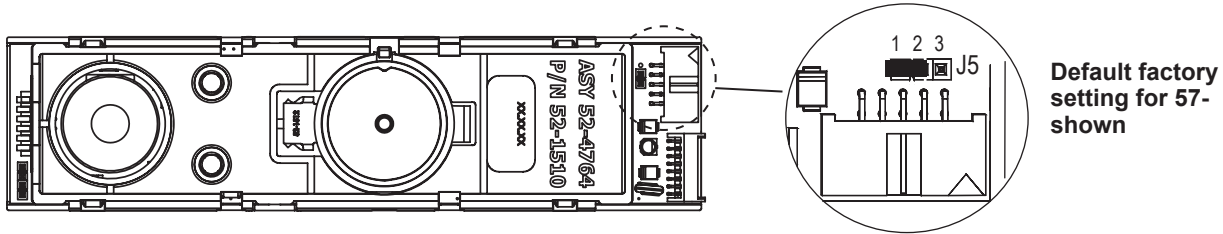

FUNCTION	JUMPER
57-	J5-1 & J5-2
59-STD	J5-2 & J5-3

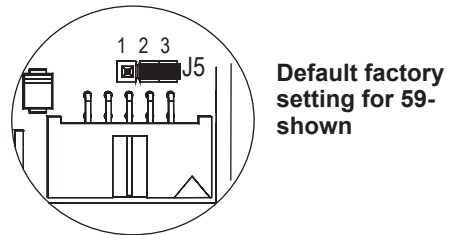

Dip Switch Settings

Installer should note DIP switch settings of **module being replaced** to ensure same settings are made for replacement module.

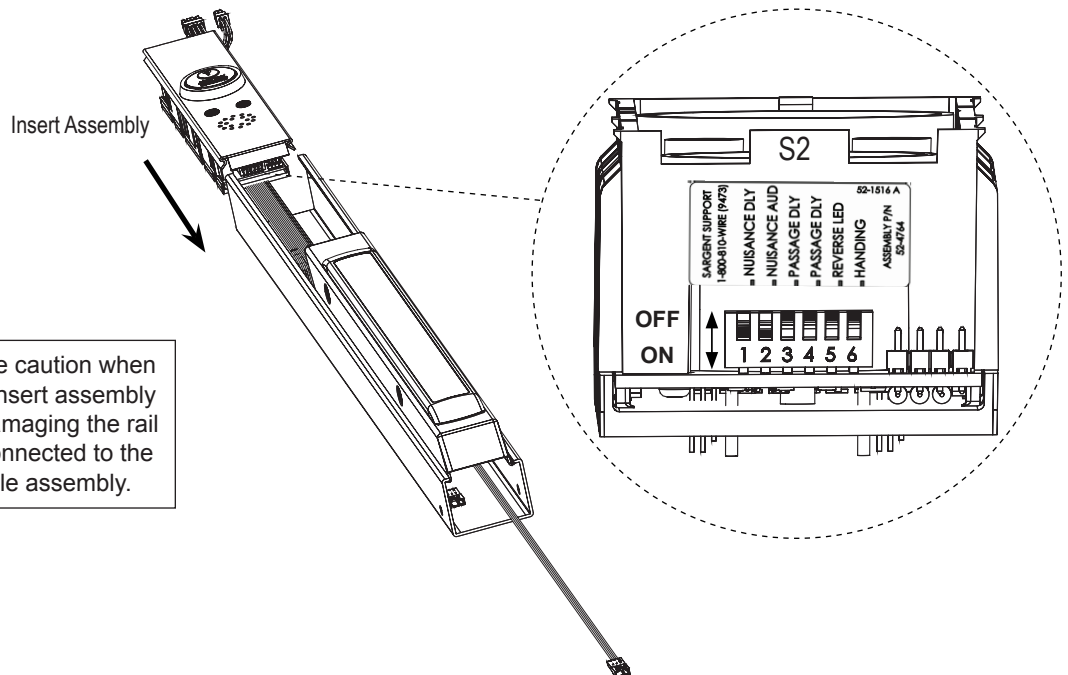

2 Replacement Instructions (Continued)

S2-1 Nuisance Delay - (Field selectable 0 or 1 second) A one second nuisance delay can be enabled by setting Dip Switch (S2-1) to the “On” position. When nuisance delay is enabled, the unit will require the push bar to be depressed for more than one second in order to trigger an irreversible alarm condition. If the push bar is released before the 1 second has elapsed, the unit will go back into the “delayed egress mode” and the alarm will not sound. Nuisance delay is set to “On” position at factory.

If the Dip Switch S2-1 is in the “Off” position, there will be no nuisance delay and alarm horn will sound immediately when the push bar is depressed.

S2-2 Nuisance Audible - (Field selectable on or off) An audible horn is enabled by setting Dip Switch S2-2 to the “On” position. The internal horn will sound as soon as the push bar is depressed, signaling that the device is armed. If the pushbar is held down for more than 1 second, an irreversible alarm condition begins. If Dip Switch S2-2 is in the “Off” position, the horn will not sound during nuisance delay.

Nuisance audible is set to “On” position at factory to sound horn when rail is depressed during nuisance delay.

S2-1 On - (1) second Nuisance Delay
S2-1 Off - No Nuisance Delay

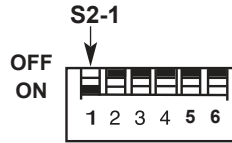

S2-2 On - Nuisance Audible On
S2-2 Off - Nuisance Audible Off

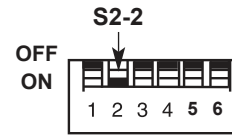

S2-3 & S2-4 Momentary Egress Time - Used to select the momentary egress time of 5, 10, 20 or 40 seconds. This switch is preset at the factory for five seconds.

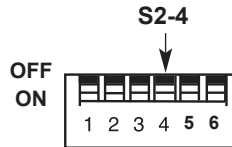
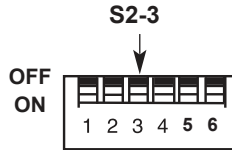

S2 Dip Switch Position		Momentary Egress Time
S2-3	S2-4	
OFF	OFF	5 seconds (Default)
OFF	ON	10 seconds
ON	OFF	20 seconds
ON	ON	40 seconds

S2-5 Reverse LED - Field selectable green or red. When S2-5 is “Off” the exit device LED is **green** when in armed mode (default) and **red** when in maintained or momentary egress mode. When S2-5 is “On” the exit device LED is **red** when in armed mode and **green** when in maintained or momentary egress.

S2-5 On - Red (Armed); Green (maintained or momentary egress)
S2-5 Off - Green (Armed); Red (maintained or momentary egress)

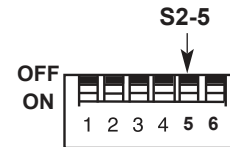

S2-6 Handing - Field selectable LHRB or RHRB. For a LHRB exit device S2-6 is “Off” for the top LED on the insert to be used when the device is armed. For a RHRB exit device S2-6 is “On” for the top LED on the insert to be used when the device is armed.

S2-6 Off - LHRB; Top LED indicates “Armed”
S2-6 On - RHRB; Top LED indicates “Armed”



3 57- Troubleshooting

The tables below are provided to assist in the installation and troubleshooting of the 57- exit device.

The following table lists the status and function of the (2) Green/Red LEDs located on the rail insert.

Visible Insert LEDs	Function
Green (Default) or Red ON only	Rail is Armed - Delayed Egress Mode
Red(Default) or Green ON only	Rail is Disarmed – Maintained (Free) Egress Mode
Red (Default) or Green “Flashing”	Rail is in Momentary Egress Mode
Green and Red “Alternate”, Rail Horn is ON	Rail is in violation

IMPORTANT: Always remove power to the rail before disconnecting or reconnecting connectors at the 57- PCB module assembly. Disconnect the 24VDC Power Supply or remove the Red (+24VDC) power wire at the rail.

The diagnostic LEDs are visible after install with end cap removed.

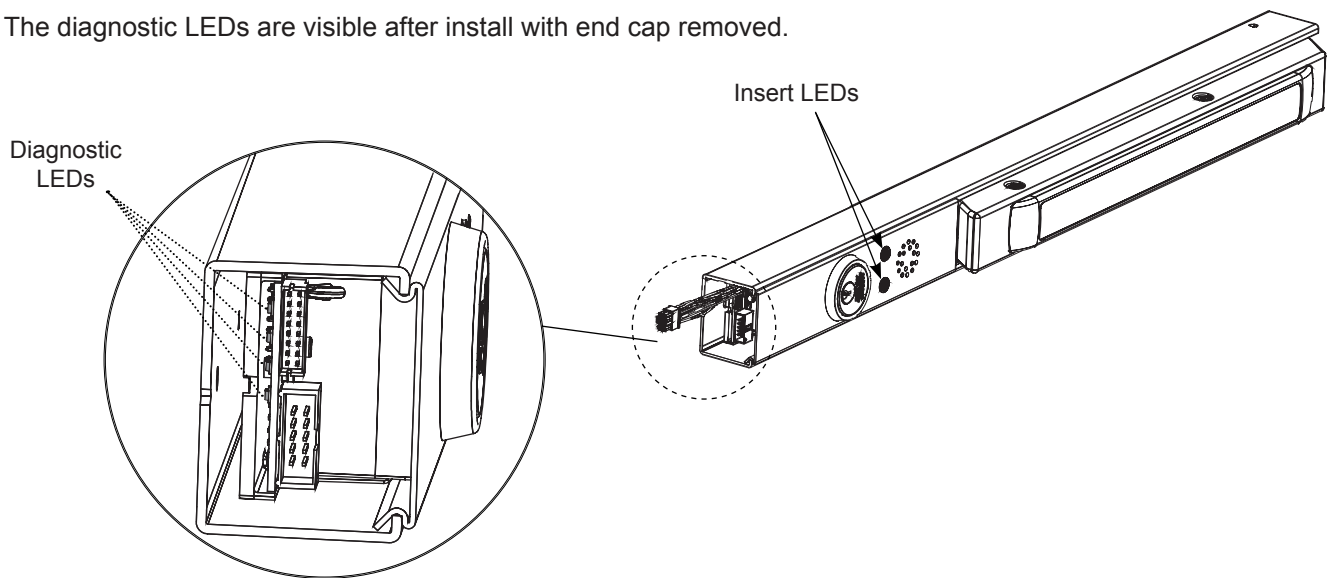

Refer to the following table and notes for an explanation of each LED's function.

Diagnostic LEDs	Function
Yellow	ON – *Jumper is missing or in wrong position OFF – should always be OFF
Green (Magnet)	ON – External Magnet is energized (+24VDC from main board) OFF – External Magnet is de-energized
Red (Push Rail Switch)	ON – Rail Push Bar is depressed OFF – Rail Push Bar is released
Orange (Door Status Switch)	ON – Door Status Switch is open. Door is open/violated. OFF – Door Status Switch is closed. Door is closed and secure.

*See Jumper position and function table on following page

3 57- Troubleshooting (Continued)

NOTES

With Rim, Mortise and Vertical Rod Exit Devices:

When jumper is missing or in wrong position, the Yellow Diagnostic LED turns ON. To locate (J5) jumper, remove Insert Assembly and Insert Assembly Plate:

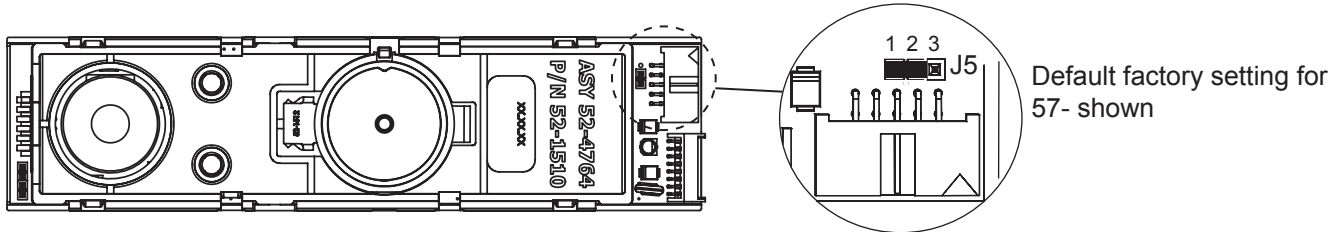

FUNCTION	JUMPER
57-	J5-1 & J5-2
59-STD	J5-2 & J5-3

1. When the rail is armed (in Delayed Egress Mode) and the door is closed and latched, the Green (default) or Red LED and the Green Diagnostic LED should be ON only. All other diagnostic LEDs should be OFF.
2. With the rail armed, depressing the rail push bar slightly will turn the Red Diagnostic LED ON. The rail should go into alarm immediately (no nuisance delay) or after being pressed in for 1 second (1-second nuisance delay). The rail will be in the irreversible alarm mode – Insert Green and Red LED flash and the rail horn sounds. After a standard delay of 15 seconds (or 30-second optional delay), the external magnet de-energizes and passage is allowed. The rail horn will continue to sound until the rail is reset either with a key or remotely.
3. When a Door Status switch is used and the door is opened the Orange Diagnostic LED will turn ON, which indicates that the door is not secure. When NOT using a Door Status switch, the Blue wire should be connected to Black (-Return). In this case, the LED will always be OFF.

MINIMUM REQUIREMENTS FOR ARMING RAIL (DELAYED EGRESS MODE)

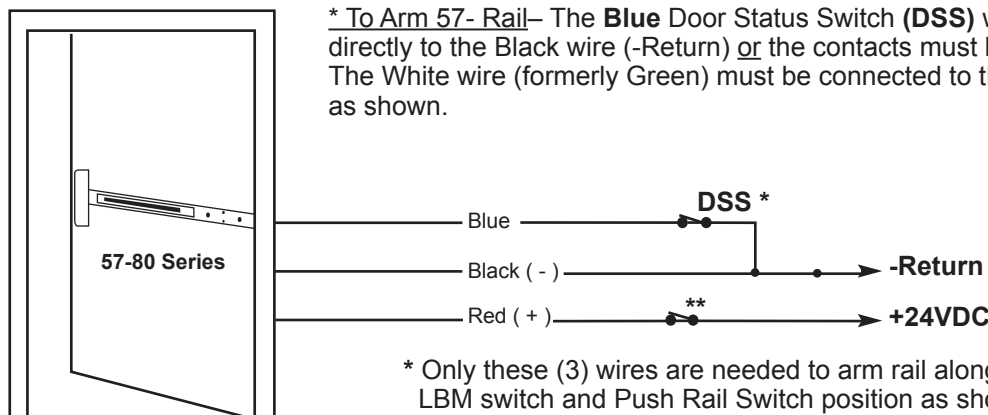

* To Arm 57- Rail– The **Blue** Door Status Switch (**DSS**) wire must be connected directly to the Black wire (-Return) or the contacts must be closed as shown. The White wire (formerly Green) must be connected to the Black wire (-Return) as shown.

* Only these (3) wires are needed to arm rail along with the correct LBM switch and Push Rail Switch position as shown before

** Fire Alarm Contact (if required)

3 57- Troubleshooting (Continued)**Symptom / Failure**

* Refer to Diagnostic LED Table/Description and Minimum Requirements to Arm Rail sections.

A. Rail won't arm - (Armed LED won't turn ON / Horn sounds immediately or after a delay) -

When trying to arm, the rail goes into alarm immediately after momentary egress times out or after a short delay after the momentary egress times out.

- Are the Yellow, Red and Orange Diagnostic LEDs OFF?

YES – Replace defective PCB module assembly.

***NO** – All of these LEDs should be OFF. Troubleshoot according to which LED is ON. If any LED stays ON after troubleshooting, consult 1-800-810-WIRE

B. Rail won't arm - (Armed LED won't turn ON / Horn stays OFF) -

- The rail is receiving an external inhibit signal

- The Orange wire is connected to Black wire (-Return) through external device or directly

- The rail is in fire alarm condition

C. Rail arms, but the external electromagnet is not energized when pushbar is depressed - (Armed LED and Green Diagnostic LED are ON) -

- Troubleshoot external electromagnet or external wiring. If wires can't be repaired, consult 1-800-810-WIRE

D. Rail Arms, but will not go into alarm when depressing push bar -

- Does the Red Diagnostic LED turn ON when depressing push bar?

YES – Replace defective PCB module assembly.

NO – The push rail hall switch is defective or out of activation range. If wires can't be repaired or if switch can't be adjusted (on rails which allow adjustment), consult **1-800-810-WIRE**.

E. Horn sounds / LEDs flash RED then GREEN and sequence every second. No diagnostic LEDs are on -

- Rail may or may not arm prior to this error code

- Check harnesses are connected to controller PCBs

- Push rail hall switch circuit defective or out of activation range. Consult **1-800-810-WIRE**



IMPORTANT: RAIL IS NOT ARMED WHEN IN THIS CONDITION!

ATTENTION:

Electrified Trim applications require a separate raceway & power transfer device. Installation of conductors or harnesses (by others) through the exit device rail is prohibited as it could lead to product performance issues up to and including product failure.

4 59- Troubleshooting

The tables below are provided to assist in the installation and troubleshooting of the 59- Electroguard™ exit device.

The following table lists the status and function of the (2) Green/Red LEDs located on the rail insert.

Visible Insert LEDs	Function
Green (Default) or Red ON only	Rail is Armed - Delayed Egress Mode
Red(Default) or Green ON only	Rail is Disarmed – Maintained (Free) Egress Mode
Red (Default) or Green “Flashing”	Rail is in Momentary Egress Mode
Green and Red “Alternate”, Rail Horn is ON	Rail is in violation

IMPORTANT: Always remove power to the rail before disconnecting or reconnecting connectors at the 59- PCB module assembly. Disconnect the 24VDC Power Supply or remove the Red (+24VDC) power wire at the rail.

The diagnostic LEDs are visible after install with end cap removed.

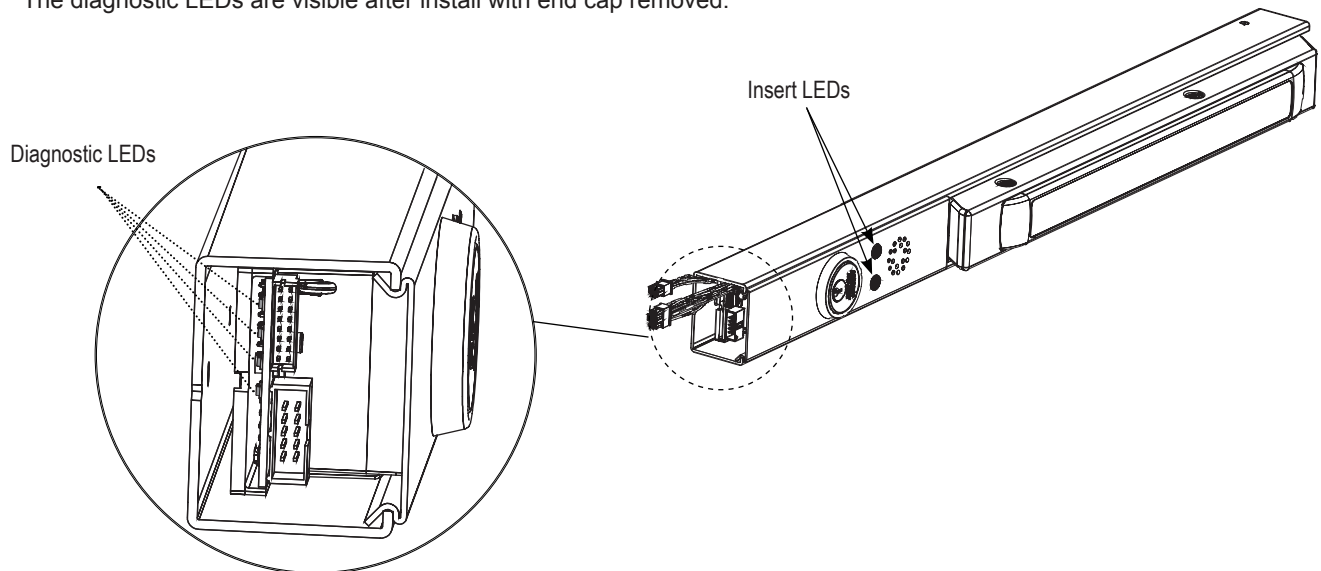

Refer to the following table and notes for an explanation of each LED's function.

Diagnostic LEDs	Function
Yellow (Latch Bolt/Rod Monitor)	ON – Latch Bolt or Vertical Rods are retracted OFF – Latch Bolt or Vertical Rods are extended/latched
Green (Magnet)	ON – Rail Magnet is energized (+24VDC from main board) OFF – Rail Magnet is de-energized
Red (Push Rail Switch)	ON – Rail Push Bar is depressed OFF – Rail Push Bar is released
Orange (Door Status Switch)	ON – Door Status Switch is open. Door is open/violated OFF – Door Status Switch is closed. Door is closed and secure

4 59- Troubleshooting (Continued)

NOTES

1. With Rim and Mortise type exit devices - When the latch bolt is retracted about half-way, the **Yellow Diagnostic LED** turns ON. The LED will be ON from half- way to the fully retracted position; otherwise the LED will be OFF.
2. With Vertical Rod type exit devices – When the rods are retracted and the door is opened, the Rod Monitor Switch is activated and the **Yellow Diagnostic LED** turns ON. The LED will remain on until the door closes and the rods are reset and engaged.
3. When the rail is armed (in Delayed Egress Mode) and the door is closed and latched, the **Green (default) or Red LED** and the **Green Diagnostic LED** should be ON only. All other LEDs should be OFF.
4. With the rail armed, depressing the rail push bar slightly will turn the **Red Diagnostic LED** ON. The rail should go into alarm immediately (no nuisance delay) or after being pressed in for 1 second (1-second nuisance delay). The rail will be in the irreversible alarm mode – **Insert Green and Red LED** flash and the rail horn sounds. After a standard delay of 15 seconds (or 30-second optional delay), the rail magnet de-energizes and passage is allowed. The rail horn will continue to sound until the rail is reset with a key.
5. When a Door Status switch is used and the door is opened the **Orange Diagnostic LED** will turn ON, which indicates that the door is not secure. When NOT using a Door Status switch, the Blue wire should be connected to Black (-Return). In this case, the LED will always be OFF.

MINIMUM REQUIREMENTS FOR ARMING RAIL (DELAYED EGRESS MODE)

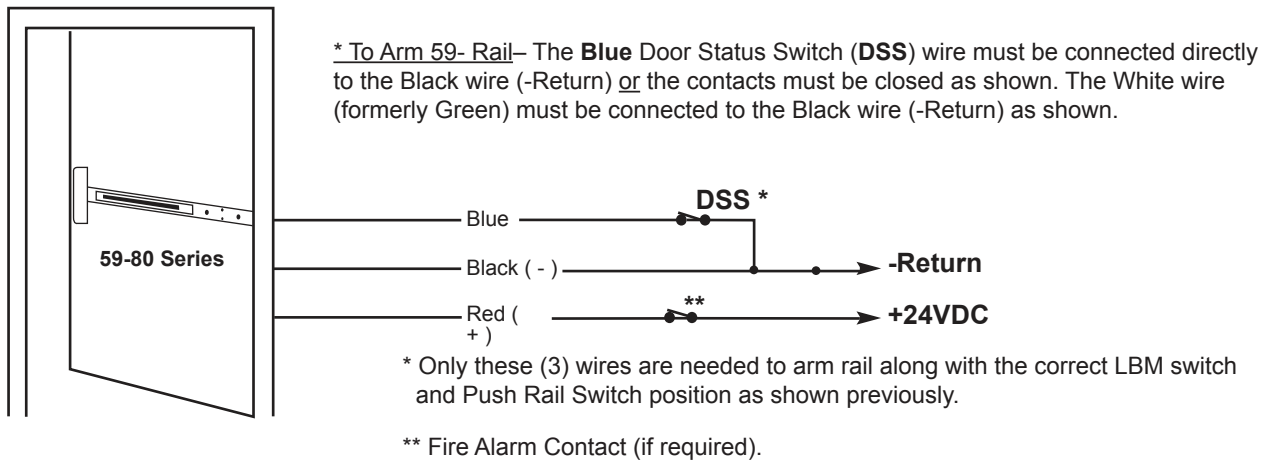

6. With Rim, Mortise and Vertical Rod exit devices - If jumper (J5) is in wrong position, the latchbolt monitor switch is bypassed (if held, will not go into alarm). To locate (J5) jumper, remove Insert Assembly and Insert Assembly Plate.

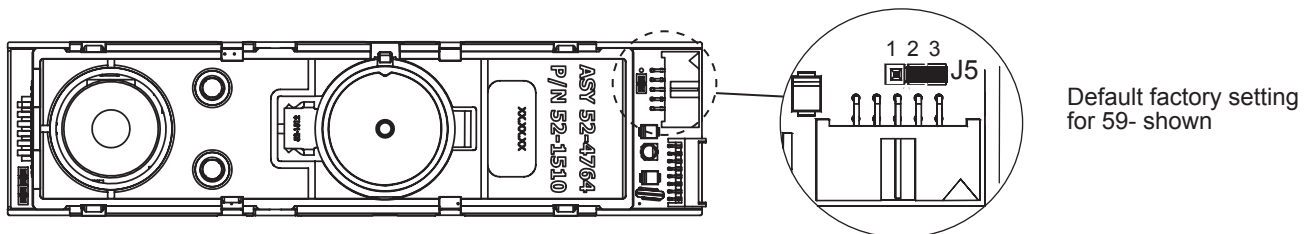

FUNCTION	JUMPER
59-STD	J5-2 & J5-3
57-	J5-1 & J5-2

4 59- Troubleshooting (Continued)

Symptom / Failure

* Refer to Diagnostic LED Table/Description and Minimum Requirements to Arm Rail sections.

A. Rail won't arm - (Armed LED won't turn ON / Horn sounds immediately or after a delay) -

When trying to arm, the rail goes into alarm immediately after momentary egress times out or after a short delay after the momentary egress times out.

- Are the Yellow, Red and Orange Diagnostic LEDs OFF?

YES – Replace defective PCB module assembly.

***NO** – All of these LEDs should be OFF. Troubleshoot according to which LED is ON. If any LED stays ON after troubleshooting, consult 1-800-810-WIRE

B. Rail won't arm - (Armed LED won't turn ON / Horn stays OFF) -

- The rail is receiving an external inhibit signal

- The Orange wire is connected to Black wire (-Return) through external device or directly

- The rail is in fire alarm condition

C. Rail Arms, but the push bar does not guard (hold back) when depressed - (Armed LED and Green Diagnostic LED are ON) -

- Defective push mechanism, rail magnet or open magnet wires. If wires can't be repaired, consult 1-800-810-WIRE

D. Rail Arms, but will not go into alarm when depressing push bar -

- Does the Red Diagnostic LED turn ON when depressing push bar?

YES – Replace defective PCB module assembly.

NO – The push rail hall switch is defective or out of activation range. If wires can't be repaired or if switch can't be adjusted (on rails which allow adjustment), consult **1-800-810-WIRE**

E. Horn sounds / LEDs flash RED then GREEN and sequence every second. No diagnostic LEDs are on -



- Rail may or may not arm prior to this error code

- Check harnesses are connected to controller PCBs

- Push rail hall switch circuit defective or out of activation range. Consult **1-800-810-WIRE**



IMPORTANT: RAIL IS NOT ARMED WHEN IN THIS CONDITION!

ATTENTION:

Electrified Trim applications require a separate raceway & power transfer device. Installation of conductors or harnesses (by others) through the exit device rail is prohibited as it could lead to product performance issues up to and including product failure.

SARGENT®

ASSA ABLOY

SARGENT Manufacturing
100 Sargent Drive
New Haven, CT 06511 USA
800-810-WIRE (9473) • www.sargentlock.com

Founded in the early 1800s, SARGENT® is a market leader in locksets, cylinders, door closers, exit devices, electro-mechanical products and access control systems for new construction, renovation, and replacement applications. The company's customer base includes commercial construction, institutional, and industrial markets.

Copyright © 2015, Sargent Manufacturing Company, an ASSA ABLOY Group company. All rights reserved. Reproduction in whole or in part without the express written permission of Sargent Manufacturing Company is prohibited.

ASSA ABLOY is the global leader in door opening solutions, dedicated to satisfying end-user needs for security, safety and convenience.

A8184B -02/15