

6000 PS or PL SERIES EXIT ONLY PUSH/PULL LATCH



NOTES

1. TRIM CAN BE MOUNTED UP, DOWN, HORIZONTALLY OR VERTICALLY. **
2. USES STANDARD 161 DOOR PREP.
3. VISION LITE MUST BE AT LEAST 6" FROM CENTERLINE OF TRIM.

ITEM	QTY	PART DESCRIPTION
1	1	COVER
2	4	8-32 x 3/8" FHMS
3	4	10-32 x 1-1/2" PAN HD M.S.
4	1	PUSH OR PULL SIDE HANDLE ASSY
5	2	#8 x 3/4" FHWS
6	1	LATCH
7	4	10-32 x 1" SEX BOLT
8	1	EXIT ONLY TRIM ASSEMBLY

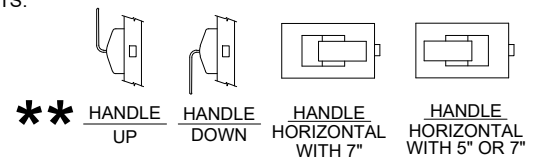
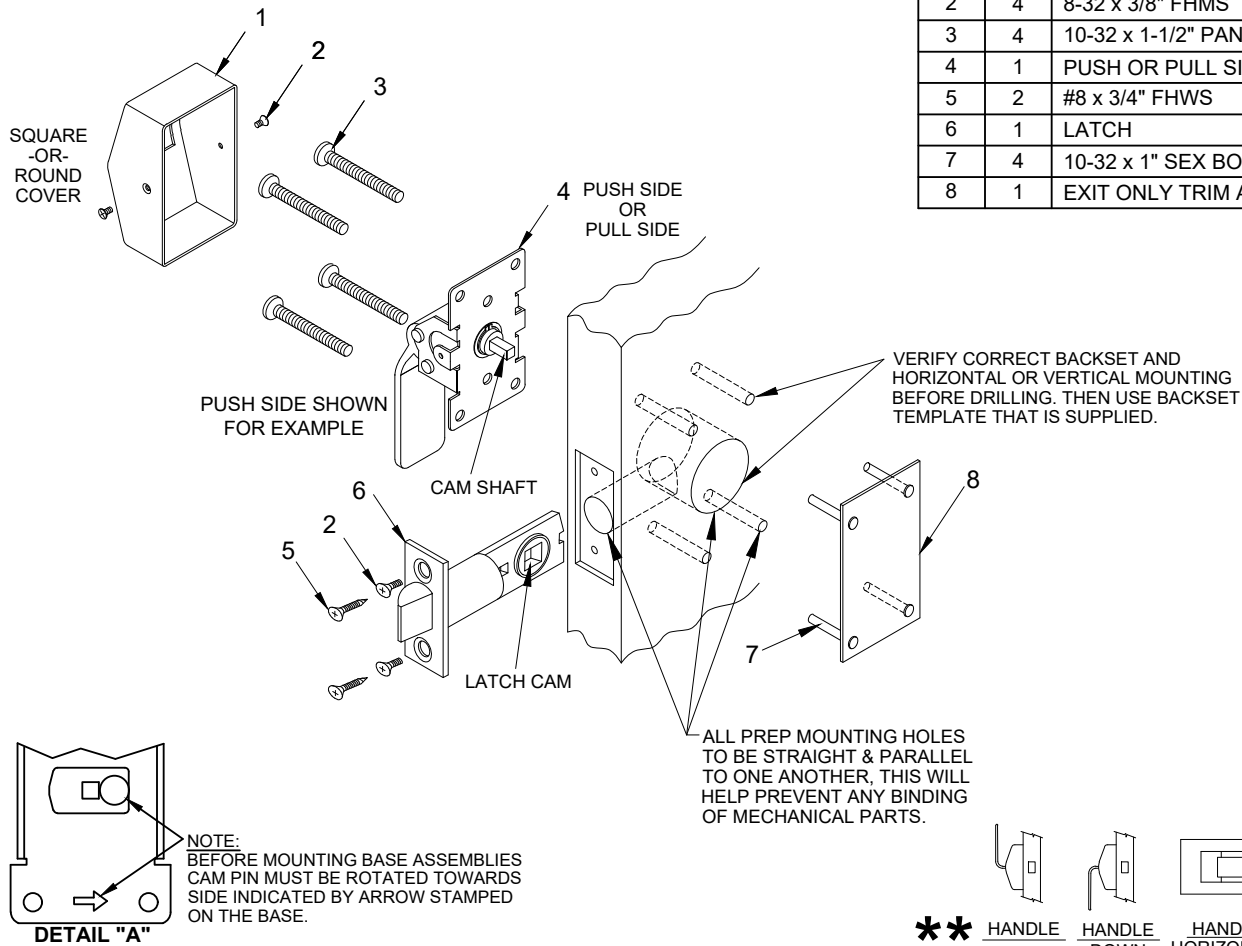

INSTALLATION INSTRUCTIONS:

1. Prep door according to latch backset and determine if trim is to be mounted horizontal or vertical mounting using backset template.
2. Install latch using either wood (item 5) or machine screws (item 2) depending on door type. Make certain bolt bevel faces the direction of door closing.
3. Place exit only plate assembly (item 8) onto appropriate side of door.
4. Place push or pull trim assembly (item 4) on appropriate side of door and slide cam shaft into latch cam. Fasten to exit only trim assembly on opposite side with (4) 10-32 screws (item 3).
5. Test for proper operation and check that the mounting hardware (item 3 & item 7) **is tight** before proceeding with the next step.
6. Place cover (item 1) over trim assembly and secure with (2) 8-32 FHMS (item 2).

PATENT No. 6,196,599



www.abhmfg.com
E-mail: abhinfo@abhmfg.com
Architectural Builders Hardware Mfg., Inc.
1222 Ardmore Ave., Itasca, IL 60143
630.875.9900; FAX 800.9FAXABH (932.9224)

© 2022 ABH Mfg., Inc.
printed in USA

6000 PS or PL

PAGE 1 OF 3

REVISED 03-02-22

6000 PS or PL-1-01.DWG

6000 PS or PL SERIES EXIT ONLY PUSH/PULL LATCH - DOOR PREP

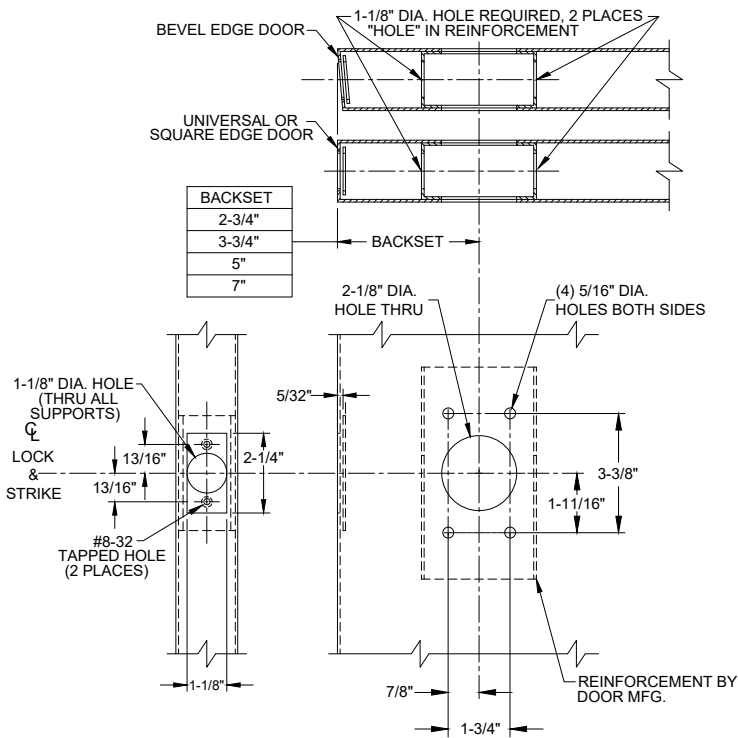

METAL DOOR

(VERTICAL MOUNTING SHOWN
SEE BELOW FOR HORIZONTAL MOUNTING)

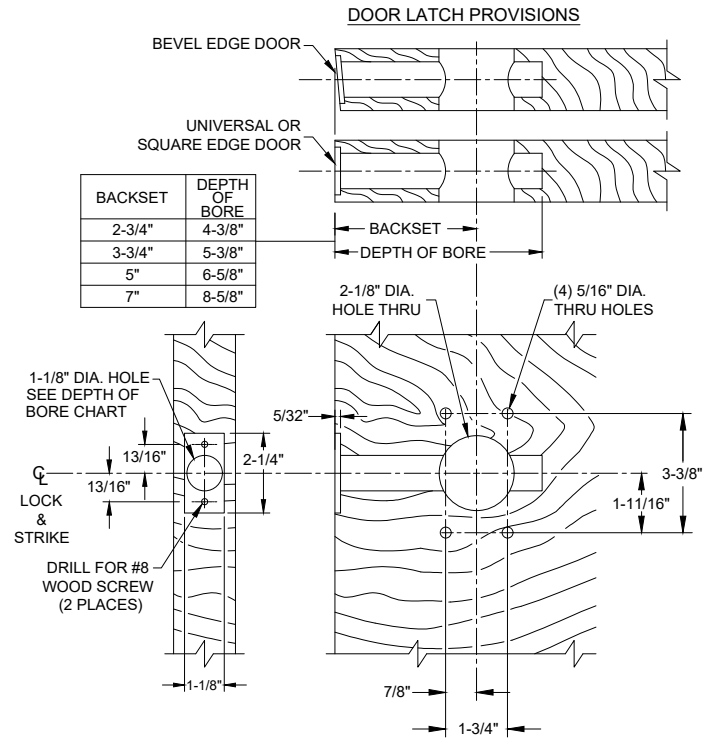

WOOD DOOR

(VERTICAL MOUNTING SHOWN
SEE BELOW FOR HORIZONTAL MOUNTING)

DOOR PREP INFORMATION:

1. BACKSET DIMENSION FROM LOW EDGE OF BEVEL.
2. CENTER PUNCH ALL HOLES.
3. DRILL HOLES (FOR HOLLOW METAL DOORS, DO NOT DRILL THRU. CENTER PUNCH & DRILL HOLES FROM BOTH SIDES OF DOOR).
4. REINFORCEMENT MUST BE APPLIED ON METAL DOORS AT THE SCREW LOCATIONS.
5. REINFORCEMENT TO BE SUPPLIED BY DOOR MANUFACTURER. THE HANDLE ASSYS MUST BE SUPPORTED. THE LATCH BOLT UNIT MUST BE SUPPORTED AND CENTERED WITHIN 1/16" OF THE CENTERLINE AT THE BACK END.

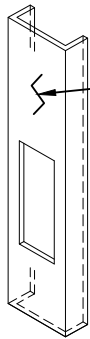

EDGE GUARD NOTE:
WHEN PREPPING THE DOOR FOR THE BACKSET, DETERMINE IF THE DOOR WILL RECEIVE AN EDGE GUARD. IF SO, THE EDGE GUARD SHOULD BE INSTALLED FIRST AND THEN THE PREP FOR THE LATCH BACKSET SHOULD BE MEASURED FROM THE OUTSIDE EDGE OF THE EDGE GUARD.

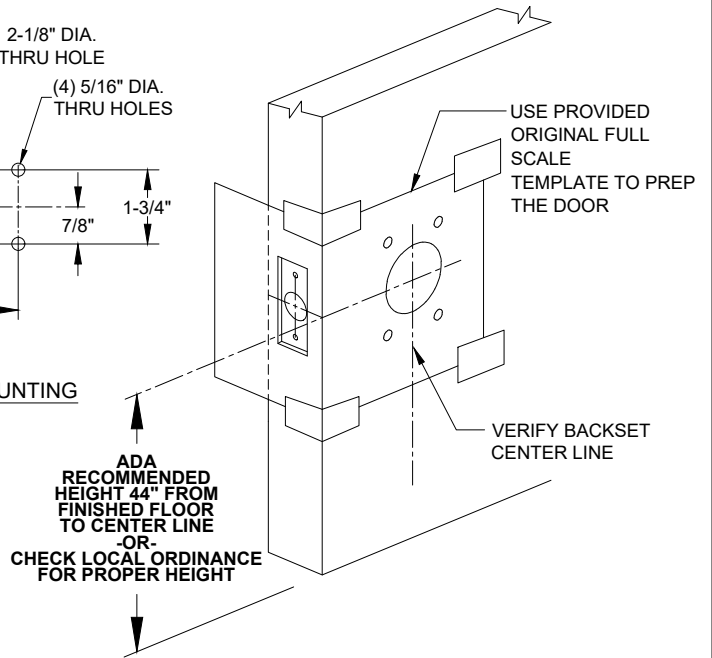
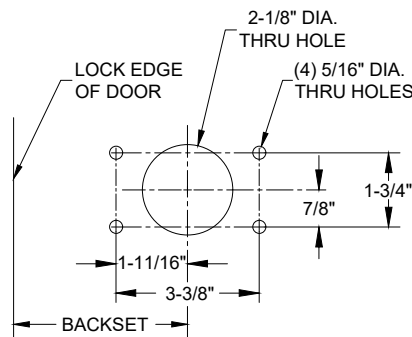

6000 PS or PL SERIES EXIT ONLY PUSH/PULL LATCH - FRAME PREP

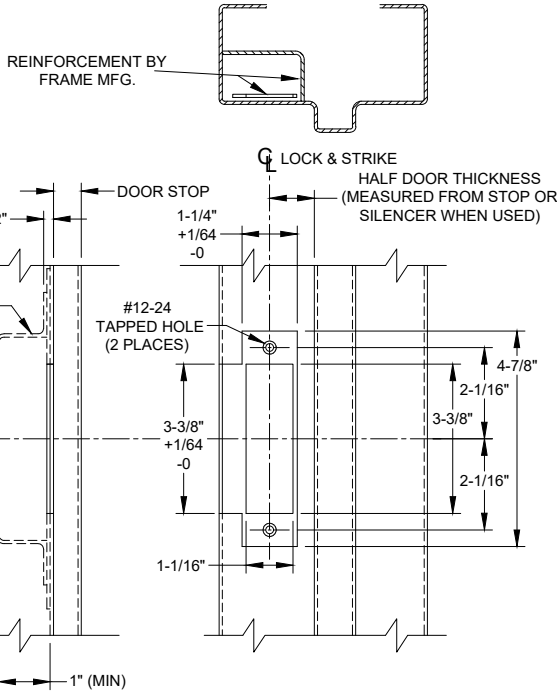

METAL FRAME
(ASA STRIKE SHOWN FOR EXAMPLE)

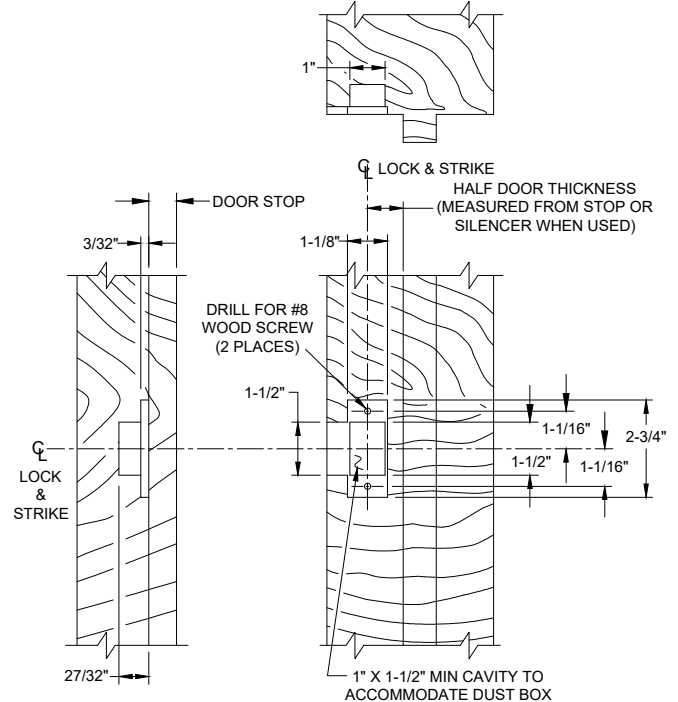

WOOD FRAME
("T" STRIKE SHOWN FOR EXAMPLE)

FRAME PREP:

1. Mark centerline of latch bolt on frame.
2. Center strike and mark screw positions.
3. Mortise to required strike and box depth.
4. All dimensions in inches.

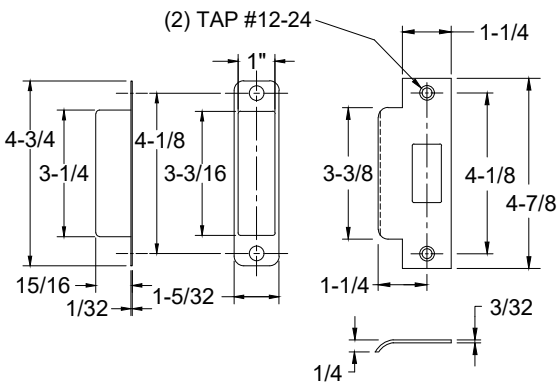
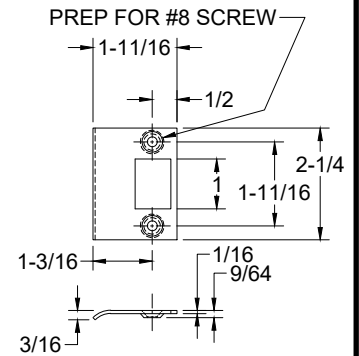
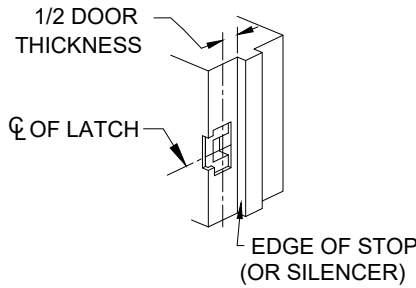

ASA STRIKE & DUST BOX

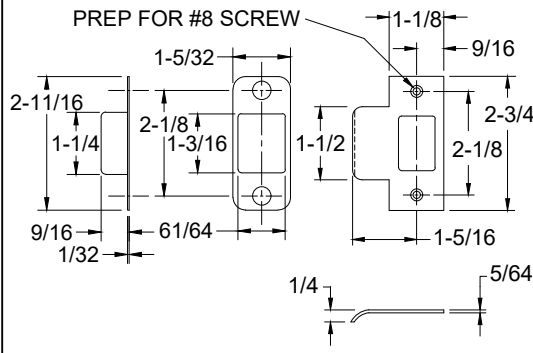

"T" STRIKE & DUST BOX

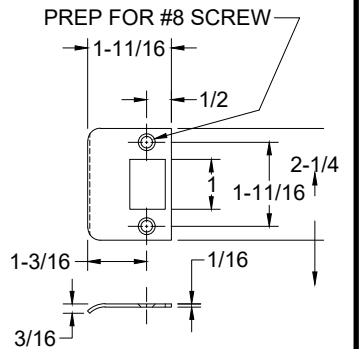

"D" STRIKE

6000 PS or PL-3-01.DWG



www.abhmfg.com
E-mail: abhinfo@abhmfg.com
Architectural Builders Hardware Mfg., Inc.
1222 Ardmore Ave., Itasca, IL 60143
630.875.9900; FAX 800.9FAXABH (932.9224)

© 2022 ABH Mfg., Inc.
printed in USA

6000 PS or PL

PAGE 3 OF 3

REVISED 03-02-22