

6000 SERIES INSTALLATION



NOTES

1. TRIM CAN BE MOUNTED UP, DOWN, HORIZONTALLY OR VERTICALLY. **
2. USES STANDARD 161 DOOR PREP.
3. VISION LITE MUST BE AT LEAST 6" FROM CENTERLINE OF TRIM.

ITEM	QTY	PART DESCRIPTION
1	2	COVER
2	6	8-32 x 3/8" FHMS
3	4	12-24 x 2-3/8" TRUSS HD. M.S.
4	1	PUSH SIDE HANDLE ASSEMBLY
5	2	#8 x 3/4" FHWS
6	1	LATCH
7	4	12-24 NUT W/ NYLON WASHER
8	1	PULL SIDE HANDLE ASSEMBLY
9	REF	SPRING
10	REF	PIN & COTTER PIN

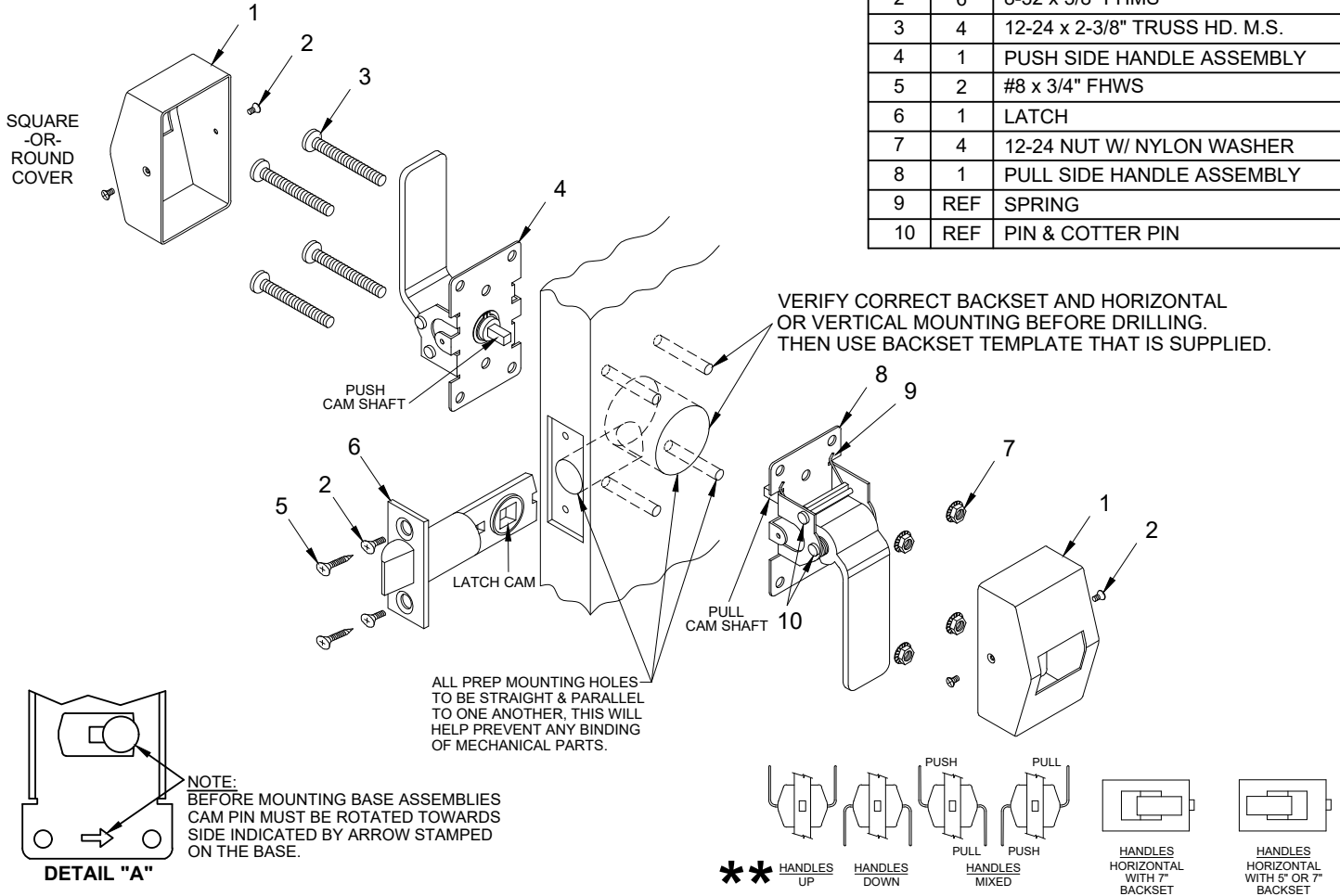

INSTALLATION INSTRUCTIONS:

1. Prep door according to latch backset and determine if trim is to be mounted horizontal or vertical mounting using backset template.
2. Install latch using either wood (item 5) or machine screws (item 2) depending on door type.
3. Install trim:
 - A) Test both handle assemblies to determine which is the push or pull type.
 - B) Select the pull handle assembly (item 8) first.
 - C) Place pull handle on pull side of the door and slide cam shaft into latch cam. Then place the push side handle assembly (item 4) on the push side of the door. Slide push side cam shaft into latch cam. By hand, fasten both trim handles with (4) 12-24 machine screws (item 3) and (4) 12-24 hex nuts (item 7). Test both handles for free movement of the latch bolt before tightening all screws. If latch bolt does not extend or retract freely because of any type of binding, loosen mounting screws to adjust alignment of trim handles and re-tighten screws one at a time while checking latch bolt movement from both handles.
 - D) Test for proper operation and check that the mounting hardware (item 3) & (item 7) **is tight** before proceeding with the next step.
 - E) Place covers (item 1) over push and pull trims and secure with (2) 8-32 flat head screws (item 2) on each cover.

PATENT No. 6,196,599

ABH
MANUFACTURING INC.

www.abhmfg.com
E-mail: abhinfo@abhmfg.com
Architectural Builders Hardware Mfg., Inc.
1222 Ardmore Ave., Itasca, IL 60143
630.875.9900; FAX 800.9FAXABH (932.9224)

© 2022 ABH Mfg., Inc.
printed in USA

6000-1-16.DWG

6000

PAGE 1 OF 3

REVISED 03-02-22

6000 SERIES PUSH/PULL LATCH - DOOR PREP

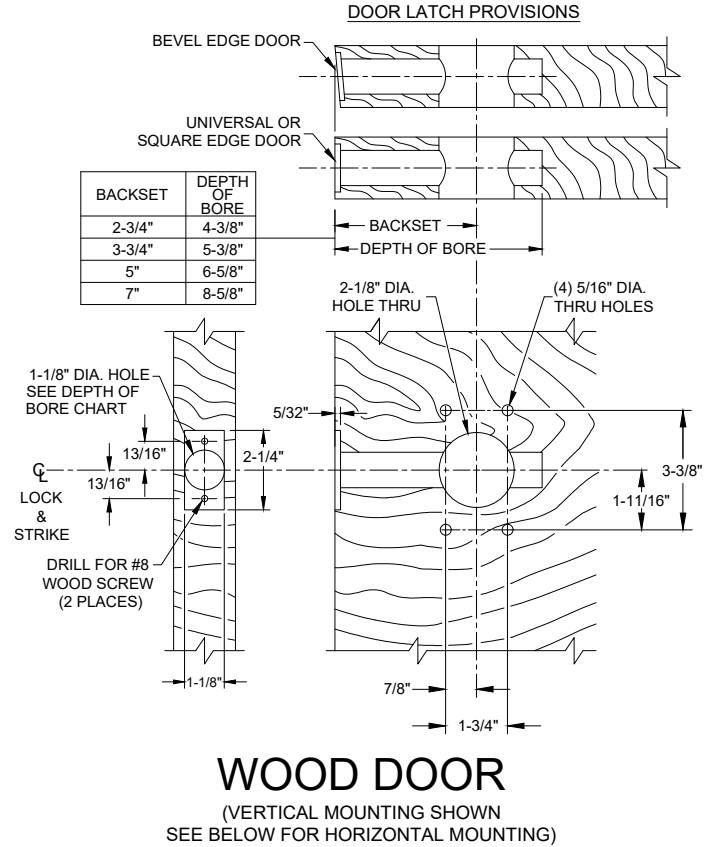
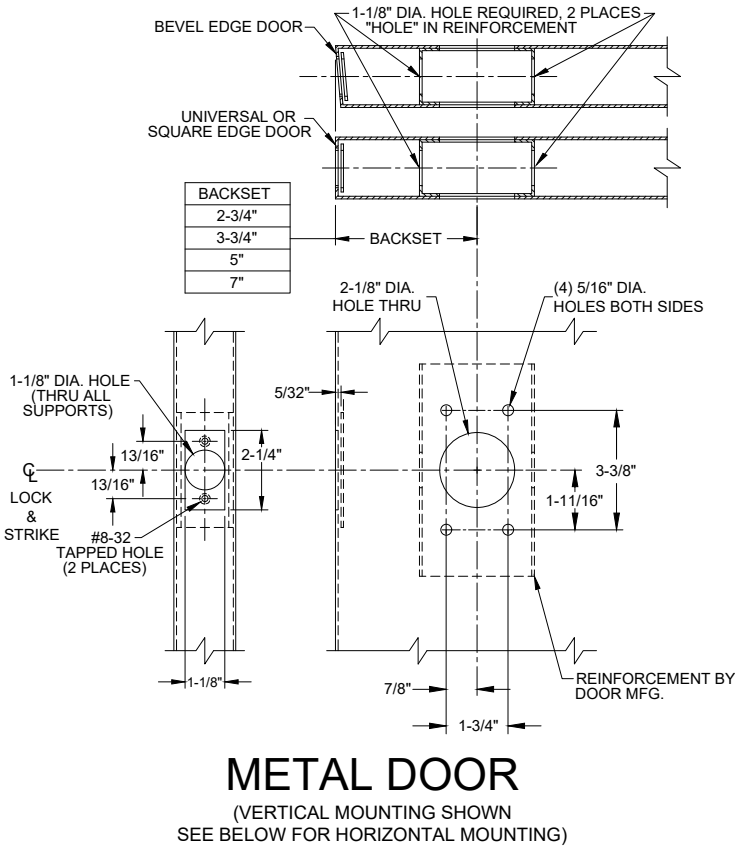

DOOR PREP INFORMATION:

1. BACKSET DIMENSION FROM LOW EDGE OF BEVEL.
2. CENTER PUNCH ALL HOLES.
3. DRILL HOLES (FOR HOLLOW METAL DOORS, DO NOT DRILL THRU. CENTER PUNCH & DRILL HOLES FROM BOTH SIDES OF DOOR).
4. REINFORCEMENT MUST BE APPLIED ON METAL DOORS AT THE SCREW LOCATIONS.
5. REINFORCEMENT TO BE SUPPLIED BY DOOR MANUFACTURER. THE HANDLE ASSYS MUST BE SUPPORTED. THE LATCH BOLT UNIT MUST BE SUPPORTED AND CENTERED WITHIN 1/16" OF THE CENTERLINE AT THE BACK END.

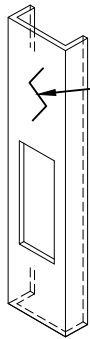

EDGE GUARD NOTE:
WHEN PREPPING THE DOOR FOR THE BACKSET, DETERMINE IF THE DOOR WILL RECEIVE AN EDGE GUARD. IF SO, THE EDGE GUARD SHOULD BE INSTALLED FIRST AND THEN THE PREP FOR THE LATCH BACKSET SHOULD BE MEASURED FROM THE OUTSIDE EDGE OF THE EDGE GUARD.

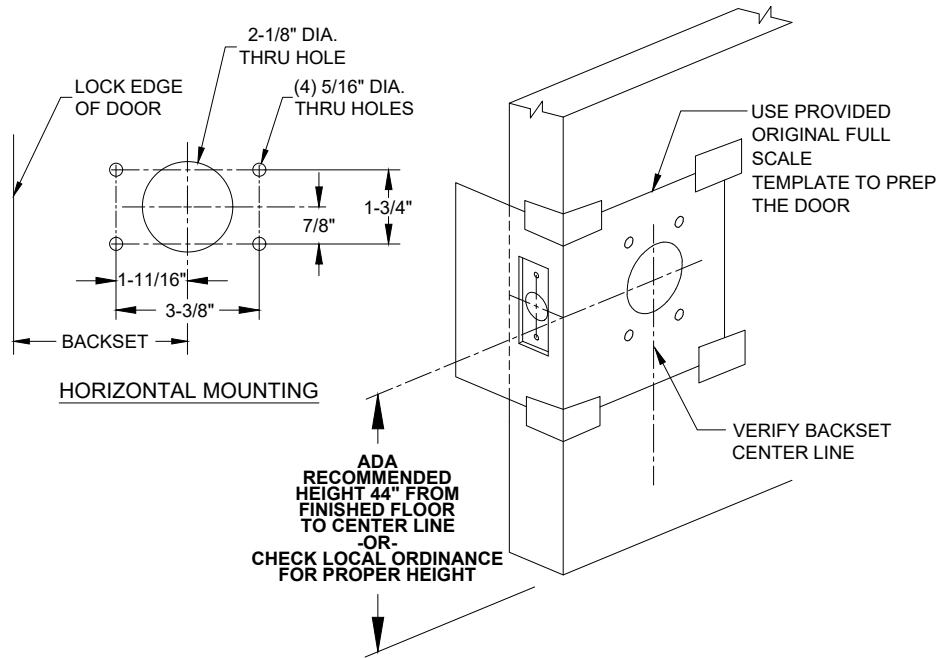

6000 SERIES PUSH/PULL LATCH - FRAME PREP

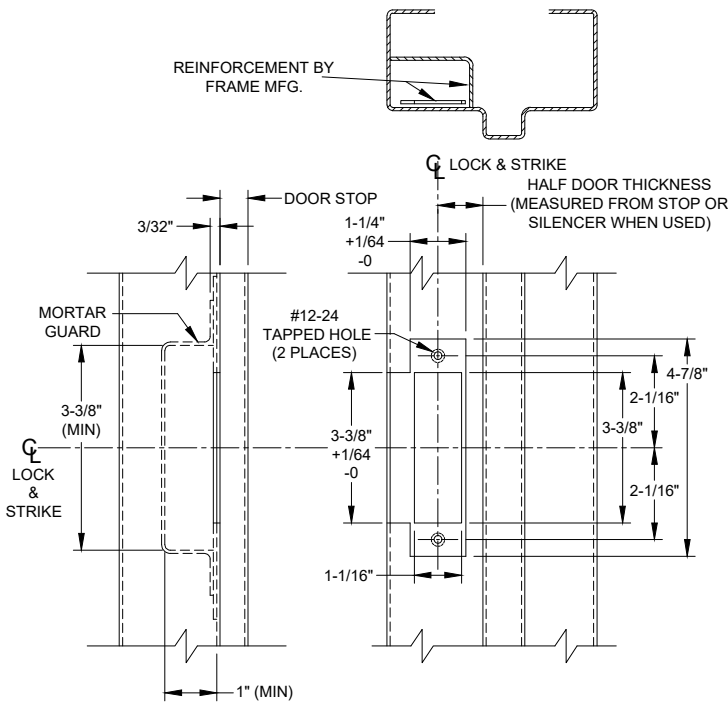

METAL FRAME
(ASA STRIKE SHOWN FOR EXAMPLE)

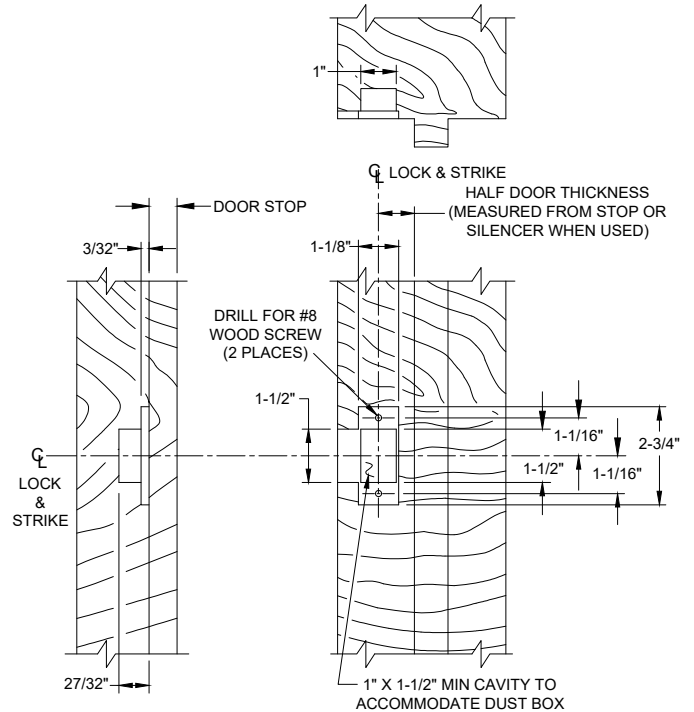

WOOD FRAME
("T" STRIKE SHOWN FOR EXAMPLE)

FRAME PREP:

1. Mark centerline of latch bolt on frame.
2. Center strike and mark screw positions.
3. Mortise to required strike and box depth.
4. All dimensions in inches.

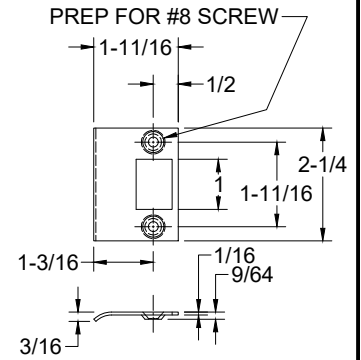
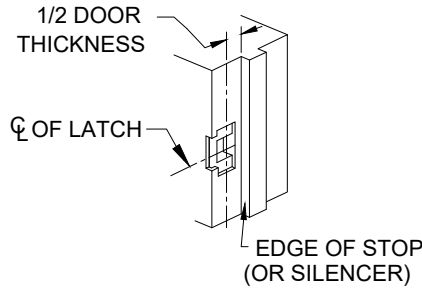

601LB STRIKE

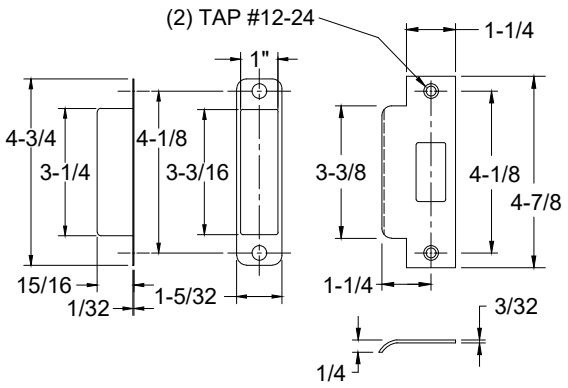

ASA STRIKE & DUST BOX

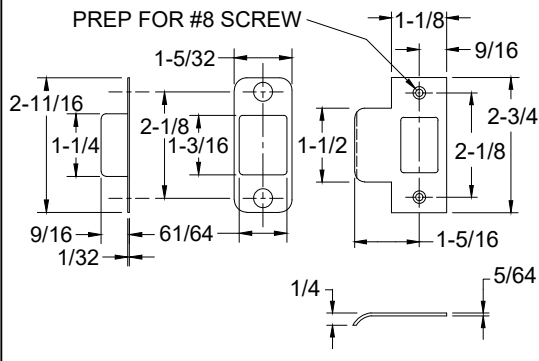

"T" STRIKE & DUST BOX

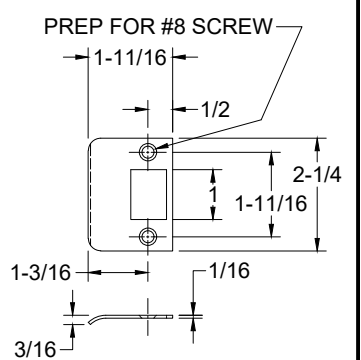

"D" STRIKE



www.abhmfg.com
 E-mail: abhinfo@abhmfg.com
 Architectural Builders Hardware Mfg., Inc.
 1222 Ardmore Ave., Itasca, IL 60143
 630.875.9900; FAX 800.9FAXABH (932.9224)

© 2022 ABH Mfg., Inc.
 printed in USA

6000-3-16.DWG

6000

PAGE 3 OF 3

REVISED 03-02-22