

8800 & 12-8800 Series

Rim Exit Device for 16, 28, 63, & 66 Functions

Product Overview

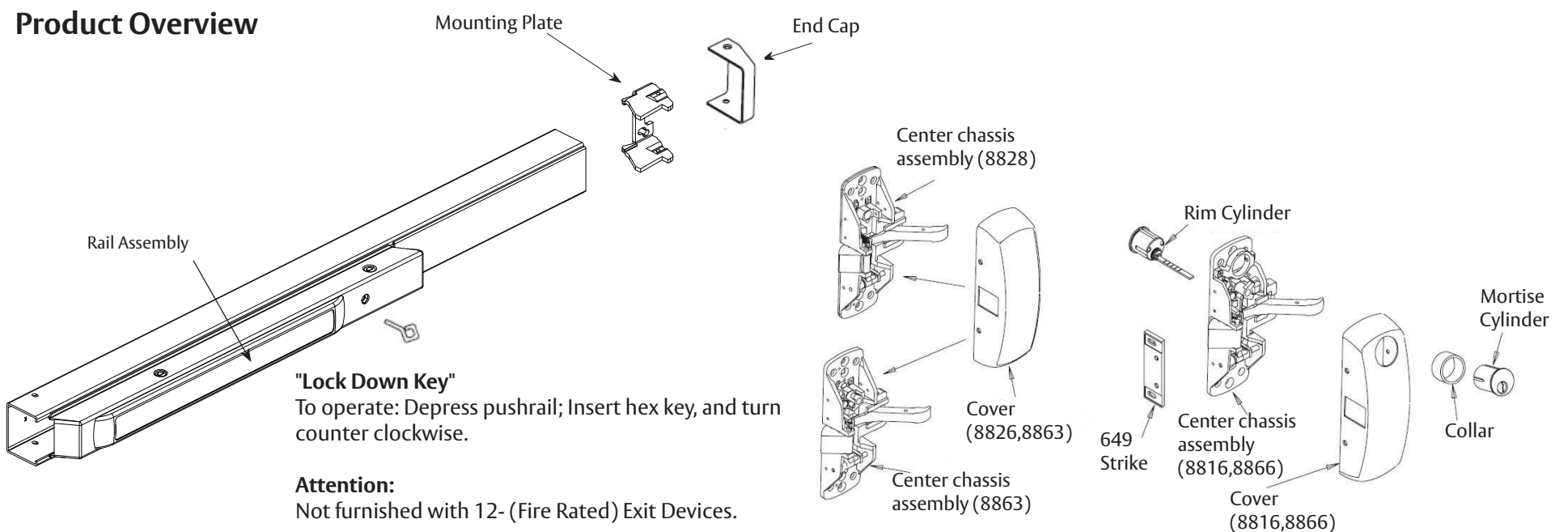

Available Stock Lengths:

- Length "E": 32" door, no cut off required. Can be cut to fit doors down to 24" wide.
- Length "F": 36" door, no cut off required. Can be cut to fit doors down to 33" wide.
- Length "J": 42" door, no cut off required. Can be cut to fit doors down to 37" wide.
- Length "G": 48" door, no cut off required. Can be cut to fit doors down to 43" wide.

Before installation:

1. Install mullion, if used.
2. Fit and hang door.
3. Check the box's label for the size of the exit device.

1 Mark vertical and horizontal reference lines of the door (See Figure 1)



Surface of the door where exit device is applied, must be flush. Clear away any raised projections to allow exit device to rest on the flat surface of the door.

a Identify type of installation to determine the location of the vertical ζ .

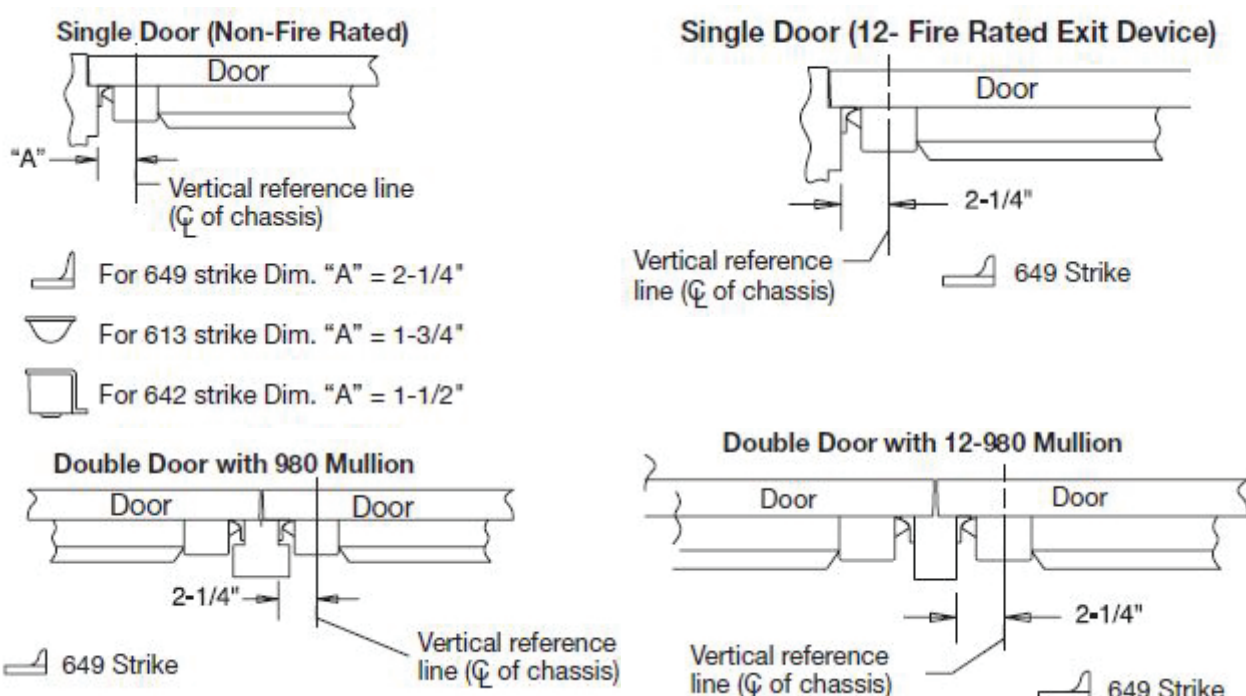
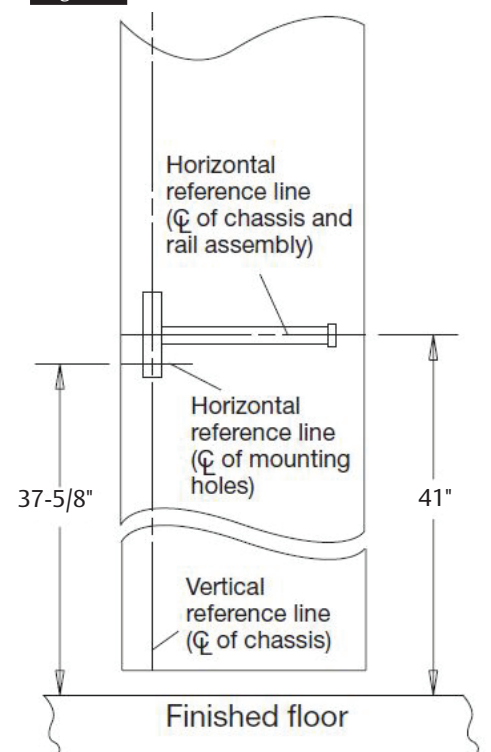
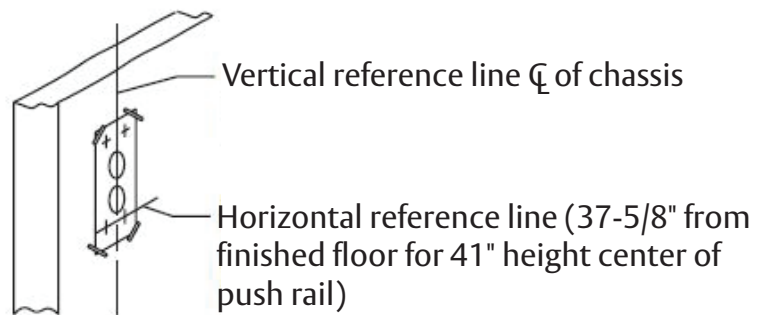

Figure 1 Vertical & Horizontal Reference



2 Prepare Door

- a** Tape template on inside of the door along the reference.
- b** Spot and drill holes.



3 Apply Hardware

- a** Attach chassis to the door with (4) #10 mounting screws.
- b** Through-bolt outside trim and cylinder chassis if used. Leave chassis screws slightly loose until after step 4b.

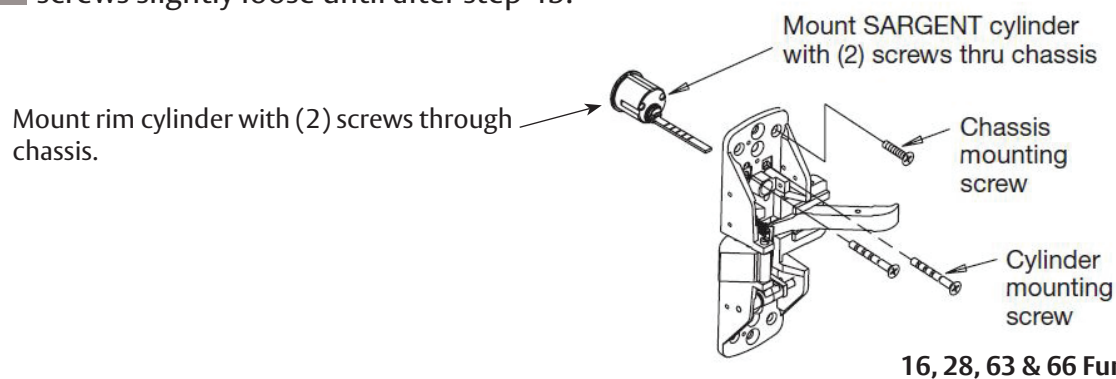

28, 63 & 66 Function

16 Function

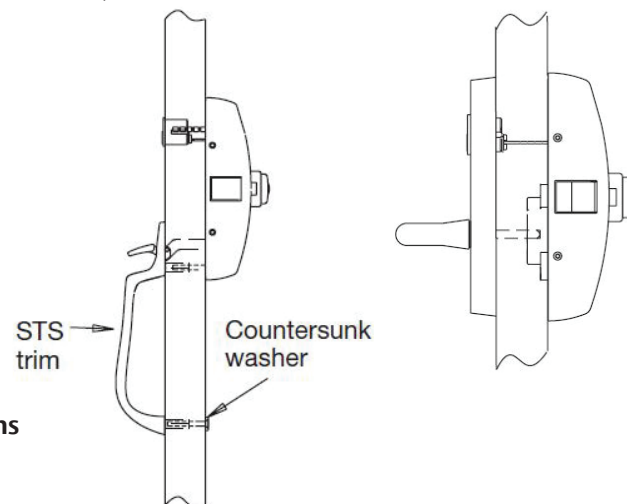

4 Apply Rail Assembly

- a** Check box label for rail size and refer to the Available Stock Lengths on page 1 for the door sizes.
 - If cutting is required, determine cut off dimension "X" by subtracting 1-3/4" from dimension "Y". (See Figure 2.) Mark cut off point on mounting rail.
 - If cutting is not required, skip to 4b.

- b** Depress arm into rail opening and slide rail onto chassis. Attach rail assembly to the chassis with two #8 truss head machine screws.

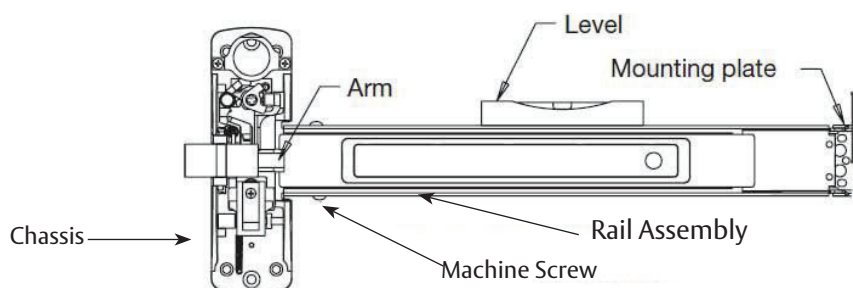

- c** Level rail. Place mounting plate tight against rail and attach it to the door with two #10 round head screws.

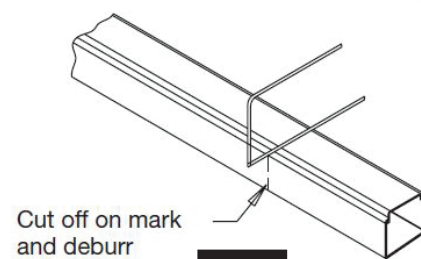
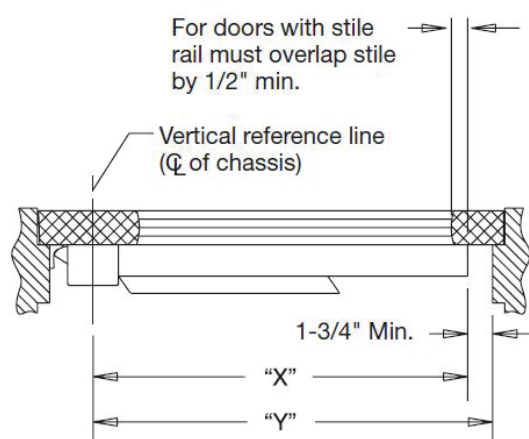
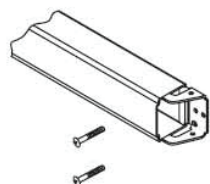
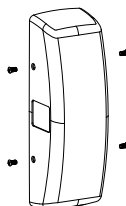

Figure 2

5 Apply Covers and Strike

- a** Attach cover to chassis with four (4) cover screws.
- b** Attach end cap to mounting plate with two cover screws.
- c** Attach 649 Strike (for Fire Rated application) with (2) outer screws and adjust for proper position. Drill and tap through the two holes in the strike frame and fasten strike in place with (2) inner screws.
- d** Attach 649 Strike (for non-Fire Rated application) with (2) strike screws and two lock washers.



WARNING

This product can expose you to lead which is known to the state of California to cause cancer and birth defects or other reproductive harm. For more information go to www.P65warnings.ca.gov.