

# CUSTOM A501 - 57" FULL SURFACE CAM HINGE, STAINLESS STEEL

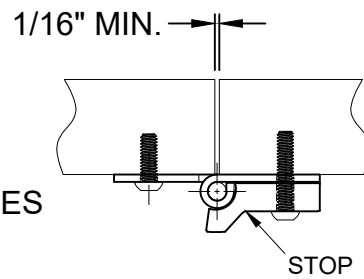

Full Closed Position  
SURFACE MOUNT

57"(4'-9")

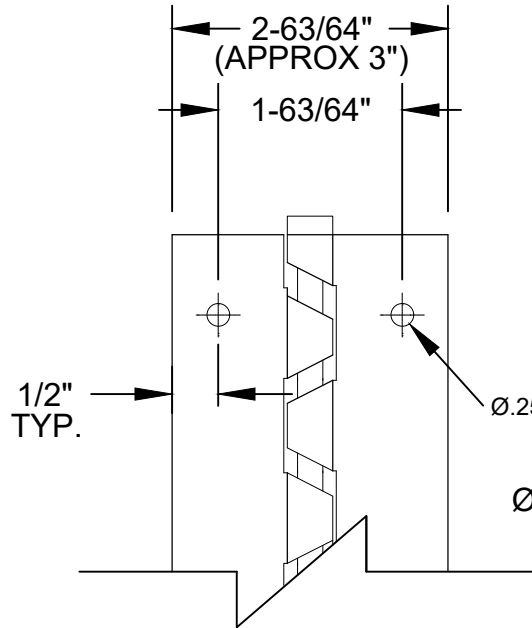
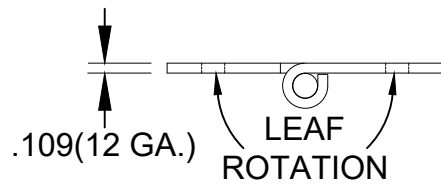
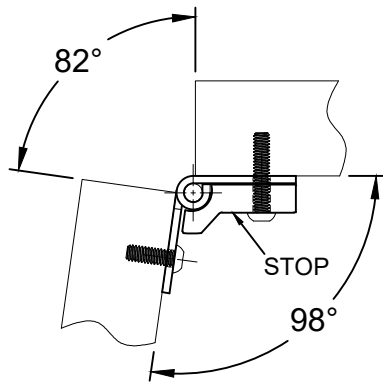
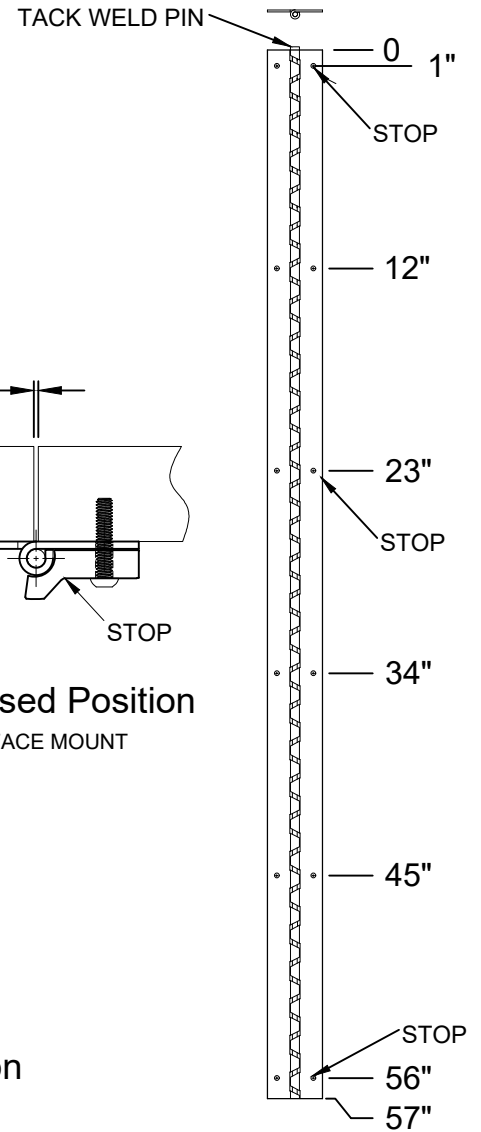

82° Full Open Position w/ Stops  
SURFACE MOUNT

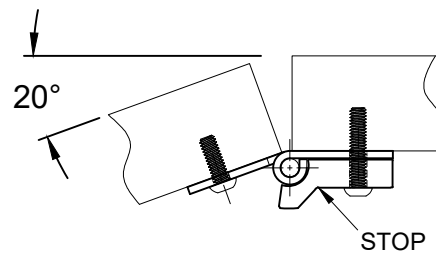

20° Open Rest Position  
SURFACE MOUNT

**NOTE :**

1. (3) CUSTOM STOPS PROVIDED FOR 100° OPENING.
2. TACK WELDED PIN - NOT STAKED

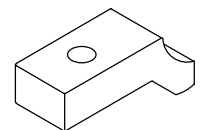

Stop

SCREW DETAIL		
	QTY.	DESCRIPTION
HINGE	12	1/4-20x3/4" PAN HEAD MACHINE SCREW-PIN TORX
STOP	3	1/4-20x1-1/4" PAN HEAD MACHINE SCREW-PIN TORX

A501-57"-01.DWG



www.abhmfg.com  
E-mail: abhinfo@abhmfg.com  
Architectural Builders Hardware Mfg., Inc.  
1222 Ardmore Ave., Itasca, IL 60143  
630.875.9900; FAX 800.9FAXABH (932.9224)

© 2021 ABH Mfg., Inc.  
printed in USA

**A501-57"**

ISSUED 4-8-21