

# A561 LS (LESS SPRING) HINGE - FULL MORTISE- NON HANDED SQUARE CORNER

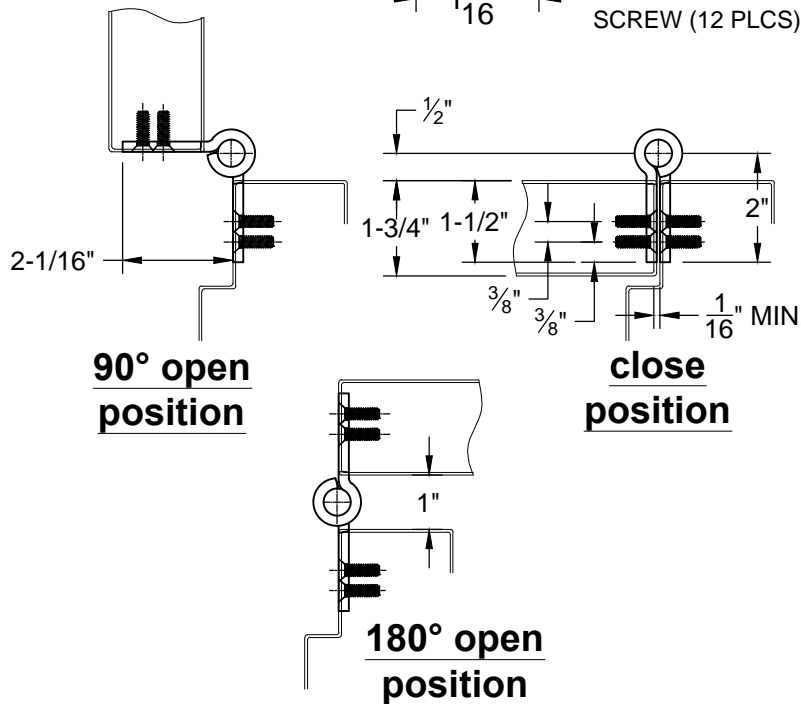
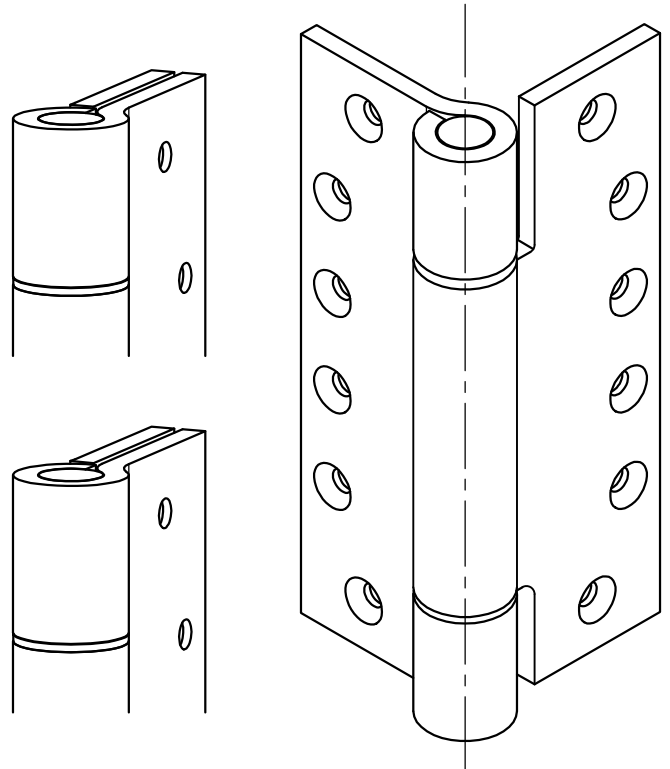
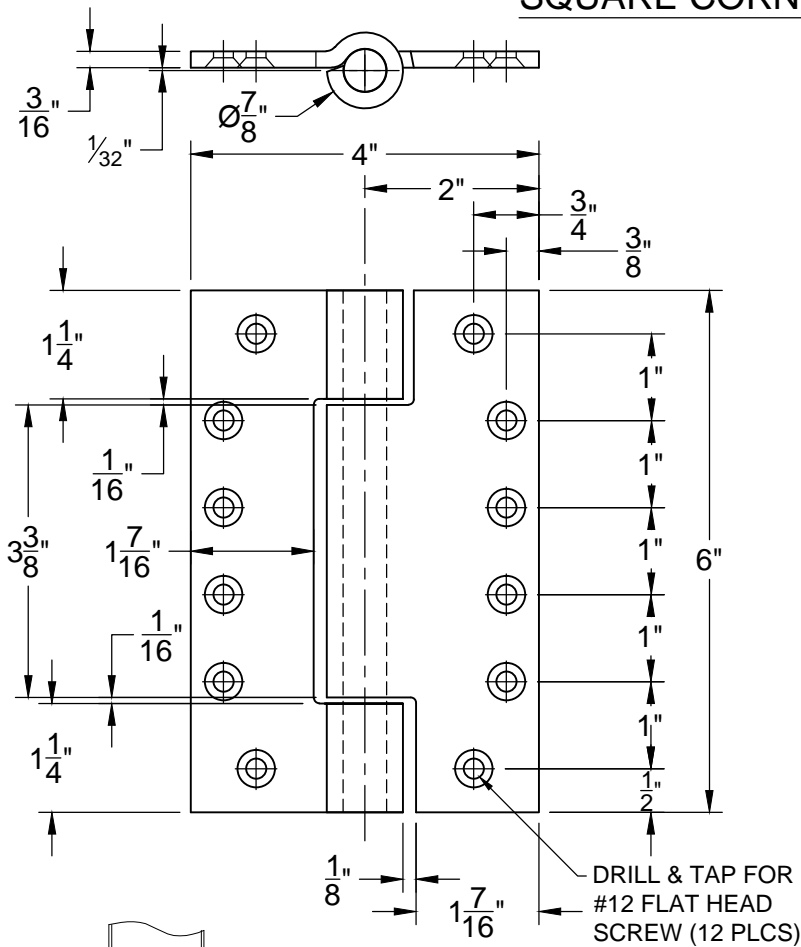

## NOTES:

1. HINGES ARE DESIGNED TO BE INSTALLED "FULL MORTISE".
2. CAN BE USED ON HOLLOW METAL OR WOOD FRAMES AND DOORS.
3. HINGES ARE NON-HANDED.
4. 1/32" TOLERANCE ON ALL PARTS
5. DO NOT SCALE DRAWING

SCREW DETAIL	
QTY.	DESCRIPTION
12	12-24x3/4" PHILLIPS FLAT HEAD MACHINE SCREW
12	#12x1-1/2" PHILLIPS FLAT HEAD SHEET METAL SCREW

A561 LS(less spring) - FULL MORTISE-00.DWG



www.abhmfg.com  
E-mail: abhinfo@abhmfg.com  
Architectural Builders Hardware Mfg., Inc.  
1222 Ardmore Ave., Itasca, IL 60143  
630.875.9900; FAX 800.9FAXABH (932.9224)

© 2019 ABH Mfg., Inc.  
printed in USA

A561 LS (LESS SPRING)  
FULL MORTISE

PAGE 1 OF 1  
ISSUED 06-26-19