

A575 - ALUMINUM GEARED HINGE, NARROW FRAME LEAF, 1/16 INSET, FULL SURFACE

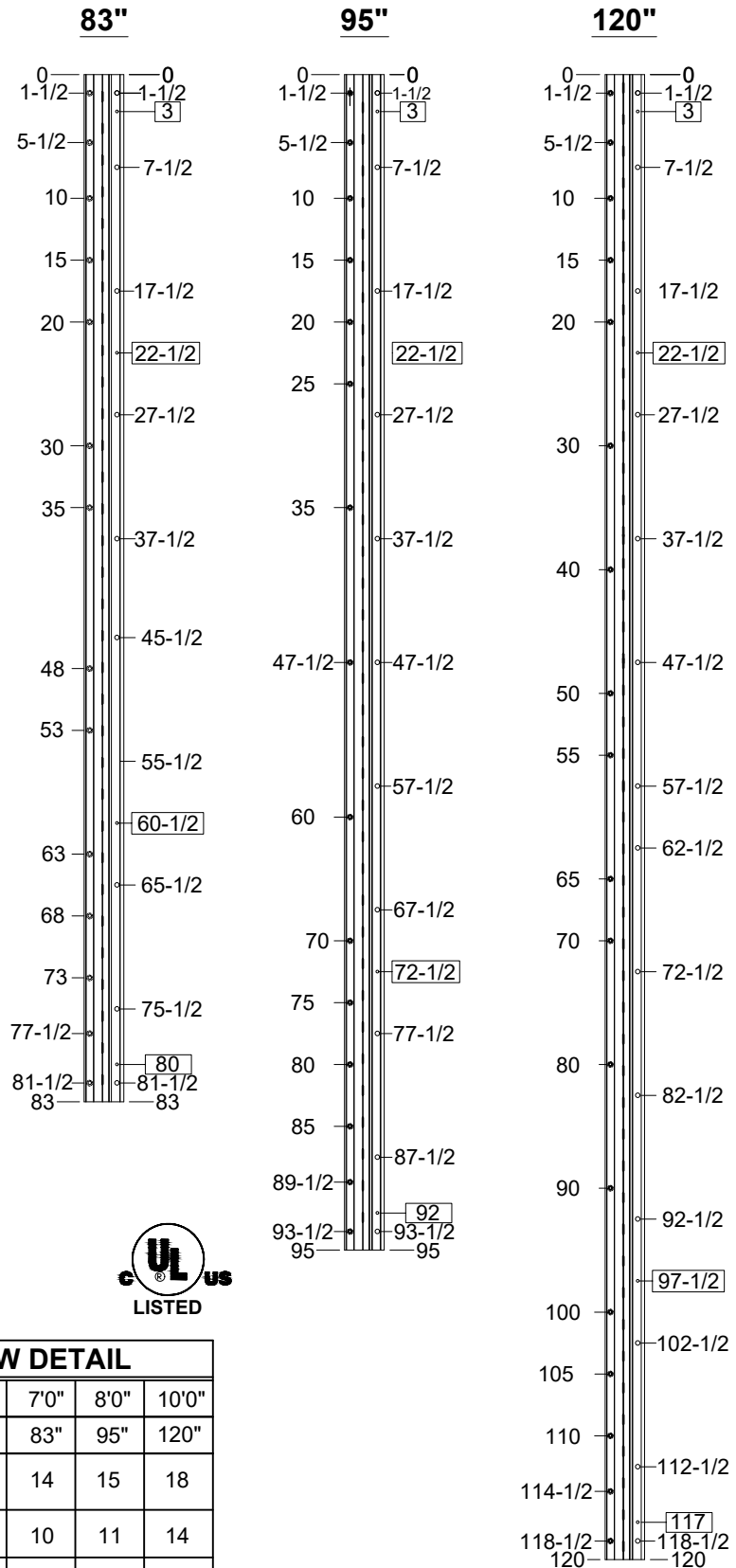

- NOTES:**
- HINGES CUT TO CUSTOM LENGTH ARE CUT FROM THE BOTTOM. PLEASE SPECIFY HANDING.
 - ALL DIMENSIONS ARE IN INCHES.
 - ALL DIMENSIONS ARE TO CENTERLINE OF HOLES.
 - TWO SET SCREWS PROVIDED ON DOOR CAP
 - XX" DENOTES LOCATOR HOLE.

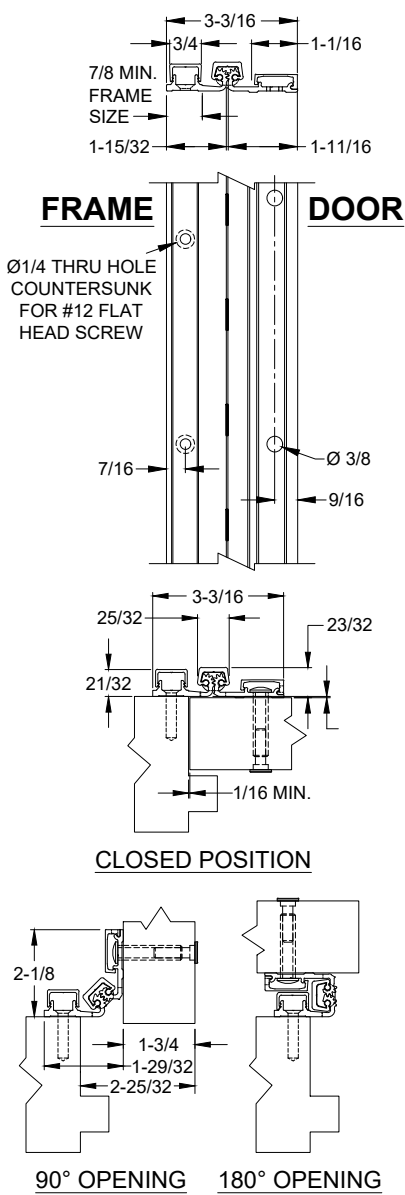

STANDARD HINGE SIZES & SCREW DETAIL

NOMINAL DOOR HEIGHT		7'0"	8'0"	10'0"
ACTUAL HINGE LENGTH		83"	95"	120"
FRAME	12-24 x 5/8" PHILLIPS FLAT HEAD, UNDERCUT, SELF DRILLING MACHINE SCREW, S.S.	14	15	18
DOOR	1/4-20 x 1-1/4" x 3/8 DIA. SEX BOLT & 1/4-20 x 1-1/4" PH. HEAD SHOULDER SCREW	10	11	14
	12-24 x 3/4" PH. PN. HD. SELF DRILLING TEK SCREW (LOCATOR HOLE)	4	4	4

A575- ALUMINUM GEARED HINGE-00.DWG



www.abhmfg.com
 E-mail: abhinfo@abhmfg.com
 Architectural Builders Hardware Mfg., Inc.
 1222 Ardmore Ave., Itasca, IL 60143
 630.875.9900; FAX 800.9FAXABH (932.9224)

© 2021 ABH Mfg., Inc.
 printed in USA

A575 ALUMINUM GEARED HINGE