

Notes:

1. Do not scale drawing.
2. Dimensions are in inches(mm).
3. LHR door shown. Preparation is typical for both door hands.
4. Minimum door stile width: 4-1/2(114).
5. Prepare mounting holes when installing the device.
6. Unreinforced frames require blind rivet nuts (by others) to mount the strike.
7. Dimension from door face.
8. For outside trim preparation see appropriate trim template.
9. Provide adequate structural support to maintain door integrity after device installation with power tools, door use, or abuse.
10. Device mount to hinge stile (not shown) requires holes location and preparation during device installation. Door structural requirements are similar for both door stiles.
11. Wood screws (#14x1-1/2"RHWS, by others) permitted for solid core wood doors if pilot holes are used for installation.

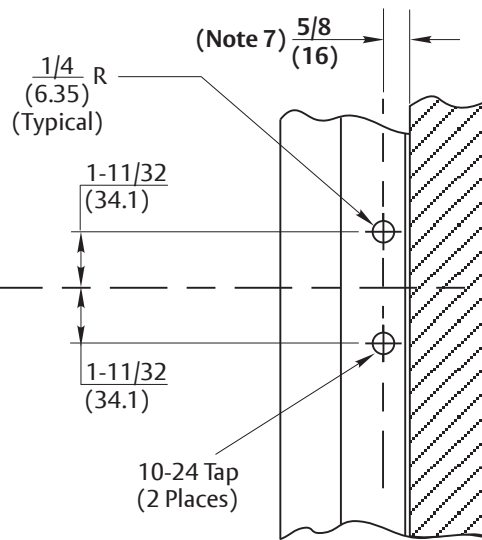
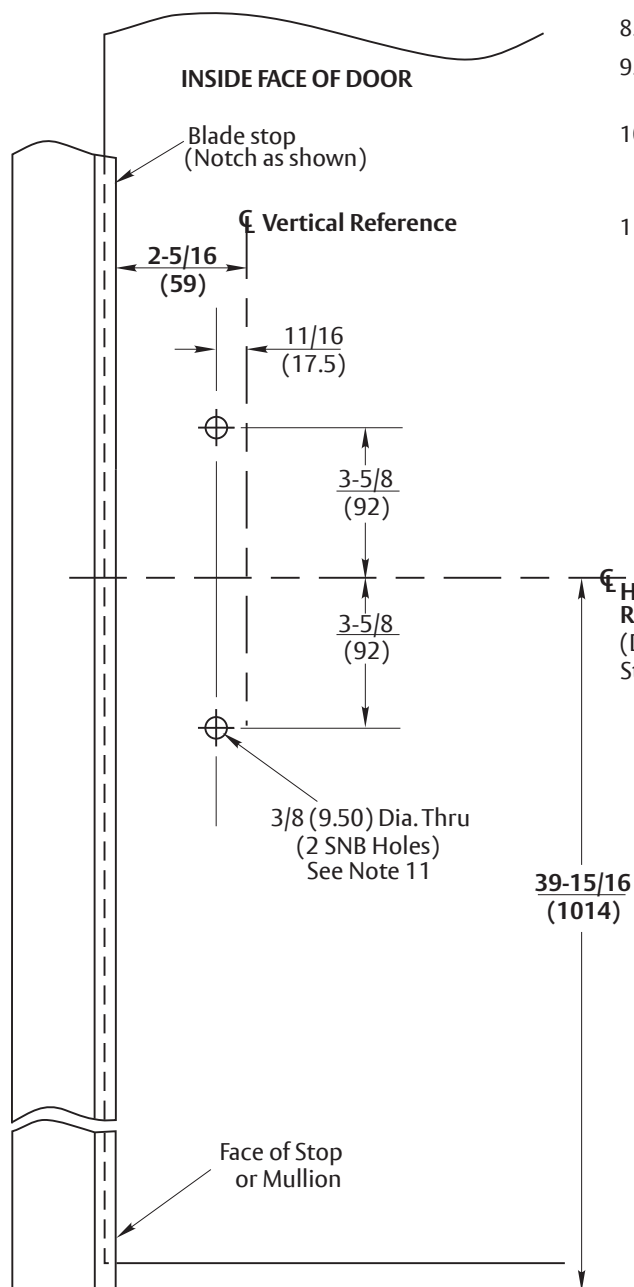

STRIKE PREPARATION DETAILS

MULLION NOTE:

FOR MULLION MODEL NUMBERS M100(F) AND KRM100(F) REFER TO TEMPLATE NUMBER 7400-0100.

FOR MULLION MODEL NUMBERS M200(F) AND KRM200(F) REFER TO TEMPLATE NUMBER 7400-0200.

FOR MULLION MODEL NUMBERS M200FWS AND KRM200FWS REFER TO TEMPLATE NUMBER 7400-0210.

RESPONSIBILITY
 DOOR AND FRAME MANUFACTURERS ARE RESPONSIBLE FOR PROVIDING ADEQUATE CONSTRUCTION OR REINFORCEMENTS FOR PROPER INSTALLATION OF HARDWARE SHOWN. ALL ARCHITECTURAL BUILDERS HARDWARE MUST BE INSTALLED ON PROPERLY REINFORCED DOORS AND FRAMES, REGARDLESS OF TYPE, MATERIAL, OR METHOD OF CONSTRUCTION.

2100 & 1800 Rim Panic Exit Devices with 757 Strike
 Application for Wood or Composite Door and H.M. Frame or Mullion
 (Not for Fire Labeled Devices)
Contact us for support at 1-855-557-5078.

ASSA ABLOY

| | | |
|-----------------|-----------|----------------------|
| SUPERSEDES | 04/10 | DO NOT SCALE DRAWING |
| TEMPLATE NUMBER | 7421-1000 | DATE |
| | | 12-23 |