

TO MORTISE DOOR FOR LOCK

1. DETERMINE CORRECT BACKSET AND DOOR THICKNESS-THEN PLACE TEMPLATE ON DOOR AND MARK FOR HOLES.

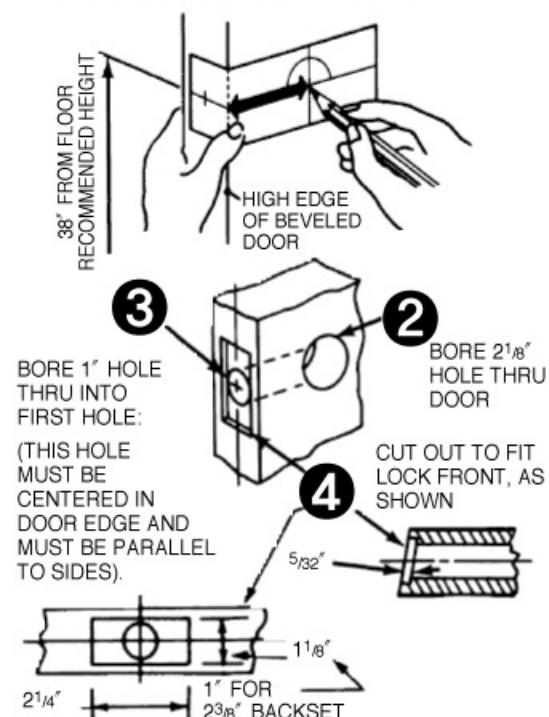

TO MORTISE FRAME FOR STRIKE

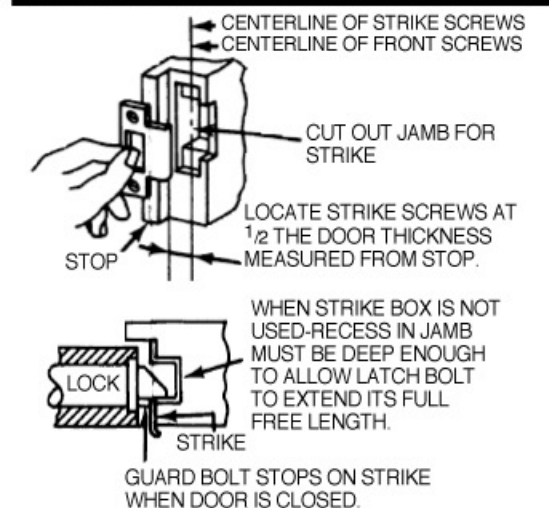

SEE REVERSE SIDE

CYLINDER REASSEMBLY

WHEN THE CYLINDER HAS BEEN REMOVED COMPLETELY (AS FOR PURPOSES OF REKEYING) REASSEMBLE AS EXPLAINED IN THE REASSEMBLY INSTRUCTIONS

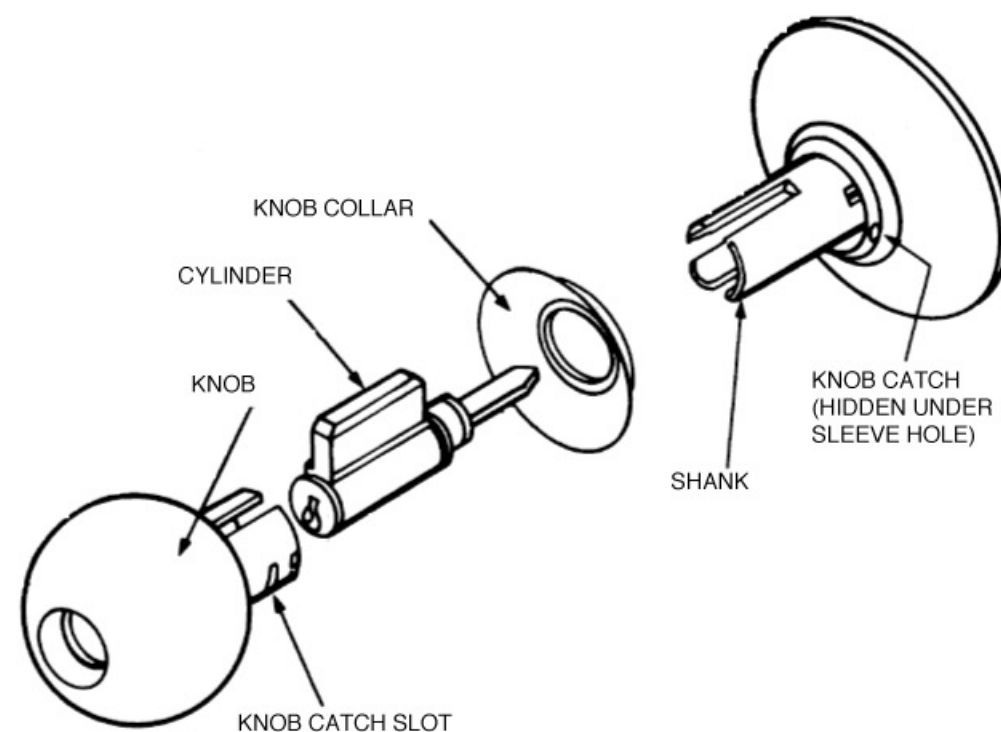

REASSEMBLY INSTRUCTIONS

1. ASSEMBLE CYLINDER INTO KNOB.
2. SLIP KNOB COLLAR OVER KNOB SHANK.
3. FULLY SEAT KNOB COLLAR AGAINST BACK OF KNOB.
4. INSERT KEY COMPLETELY INTO CYLINDER (FOR CLASSROOM FUNCTION SEE LINE #5, FOR STOREROOM & ENTRANCE FUNCTIONS SEE LINE #6)
5. CHECK THAT THE SLOTTED MEMBER IN LOCK BODY WHICH ENGAGES CYLINDER TAIL PIECE HAS BEEN ROTATED CLOCKWISE COMPLETELY AND IS IN A HORIZONTAL POSITION PRIOR TO PUSHING KNOB ON TO SHANK.
6. PUSH KNOB ASSY. ON TO SHANK. (KEYWAY VERTICAL & DOWN) UNTIL IT HITS KNOB CATCH.
7. ROTATE KEY COUNTERCLOCKWISE 1/4 TURN.
8. DEPRESS KNOB CATCH WITH KEY WRENCH, PUSH KNOB UNTIL KNOB CATCH "CLICKS" INTO POSITION.

A6760D

A

INSTALL LATCH UNIT

AFTER PREPARING DOOR AND JAMB ACCORDING TO TEMPLATE PROVIDED MOUNT LATCH UNIT IN DOOR.

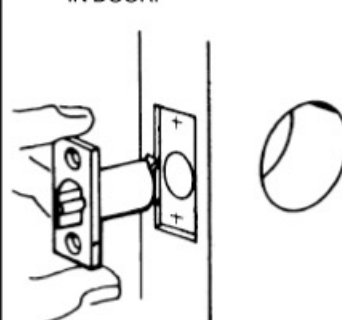

B

REMOVE INSIDE KNOB

IF RECEIVED WITH KNOB ENGAGED DEPRESS KNOB CATCH WITH PUSH PIN PROVIDED AND PULL KNOB OFF SPINDLE

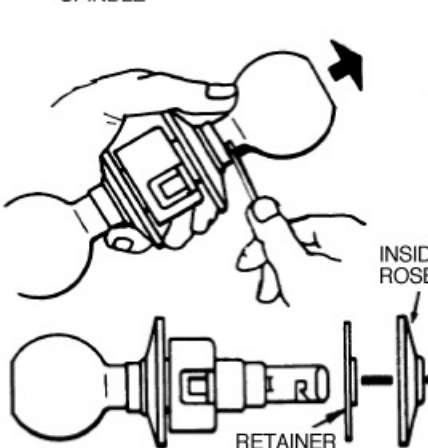

REMOVE ROSE AND RETAINER PLATE

C

ADJUST FOR DOOR THICKNESS

ROTATE OUTSIDE ROSE IN OR OUT DEPENDING ON DOOR THICKNESS LOCK WILL FIT ANY DOOR FROM 1 3/8" TO 1 3/4"

1/8" GAP FOR 1-3/8" DOORS
1/4" GAP FOR 1-3/4" DOORS

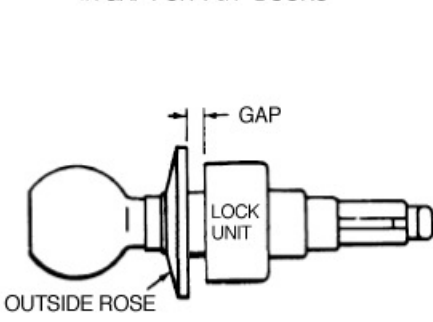

D

INSTALL LOCK UNIT

LOCK UNIT HOUSING MUST ENGAGE LATCH UNIT PRONGS AND RETRACTOR MUST ENGAGE LATCH TAILPIECE. NOTE: IF GUARD BOLT FUNCTION IS INSTALLED DO NOT ATTEMPT TO MOUNT LOCK UNIT WHEN DOOR IS CLOSED. GUARD BOLT TAILPIECE WILL INTERFERE. NOTE: DEPRESS LATCH BOLT SLIGHTLY TO ALLOW RETRACTOR TO ENGAGE LATCH TAILPIECE.

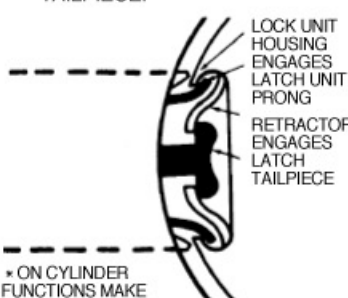

* ON CYLINDER FUNCTIONS MAKE SURE KEYWAY IS VERTICAL AND DOWN SEE NOTE BELOW TO REVERSE CYLINDER

E

ATTACH INSIDE ROSE

SNAP ON ROSE: SLIP ON RETAINER PLATE AND FASTEN WITH TWO MACHINE SCREWS. POSITION SPRING CLIP NOTCH AND SNAP ROSE OVER RETAINER PLATE.

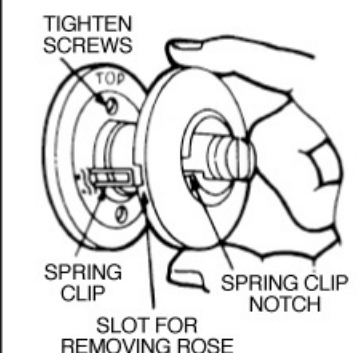

F

REPLACE INSIDE KNOB

LINE UP SLOT IN SHANK WITH KNOB CATCH IN SPINDLE. SLIDE KNOB ON TO SPINDLE DEPRESS KNOB CATCH AND PUSH KNOB INTO ENGAGED POSITION.

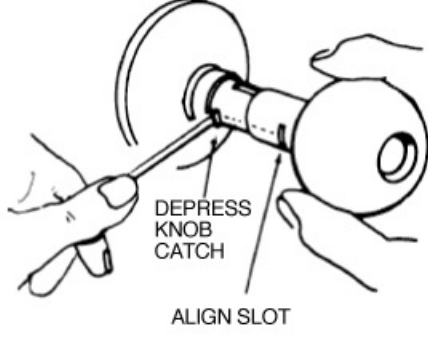

G

NOTE: WHEN A CYLINDER FUNCTION LOCK IS CORRECTLY INSTALLED, THE KEY SHOULD ENTER IN THIS POSITION.

IF NOT, REVERSE CYLINDER AS FOLLOWS:

1. WITH OUTSIDE KNOB UNLOCKED, INSERT KEY INTO CYLINDER. ROTATE KEY 1/4 TURN COUNTERCLOCKWISE.
2. PRESS KEY WRENCH INTO HOLE IN SLEEVE AND PULL OUT KNOB UNTIL SLOT AT TOP OF SPINDLE IS VISIBLE.
3. USING KNOB, TURN CYLINDER 180° (SO THAT KEYWAY IS VERTICAL AND DOWN) THEN PUSH KNOB BACK UNTIL IT HITS KNOB CATCH (WIGGLE KEY SLIGHTLY IF NECESSARY).
4. ROTATE KEY 1/4 TURN COUNTERCLOCKWISE, DEPRESS KNOB CATCH AND PUSH KNOB UNTIL CATCH CLICKS INTO POSITION.

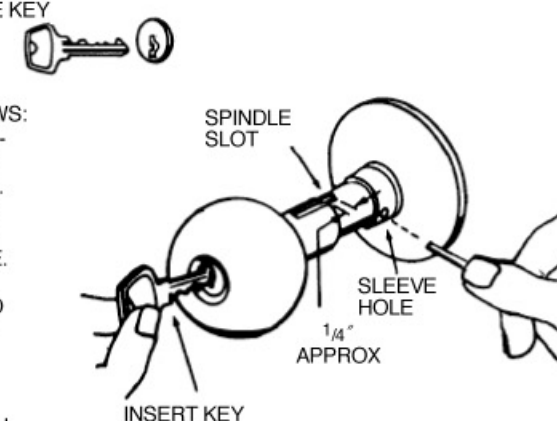

SEE REVERSE SIDE FOR CYLINDER KNOB REASSEMBLY

A6760D

