

# INSTRUCTIONS FOR INSTALLING CONVERTIBLE THRUBOLT LEVER HANDLE SET

◆ **THRUBOLTS ARE PROVIDED AND RECOMMENDED FOR USE ON HIGH FREQUENCY DOORS.**

Must use #12-28UNF×9/32", If thrubolts not installed. Must use #10-32UNF×1 3/8" (packed with convertible thrubolts) in installing convertible thrubolt.

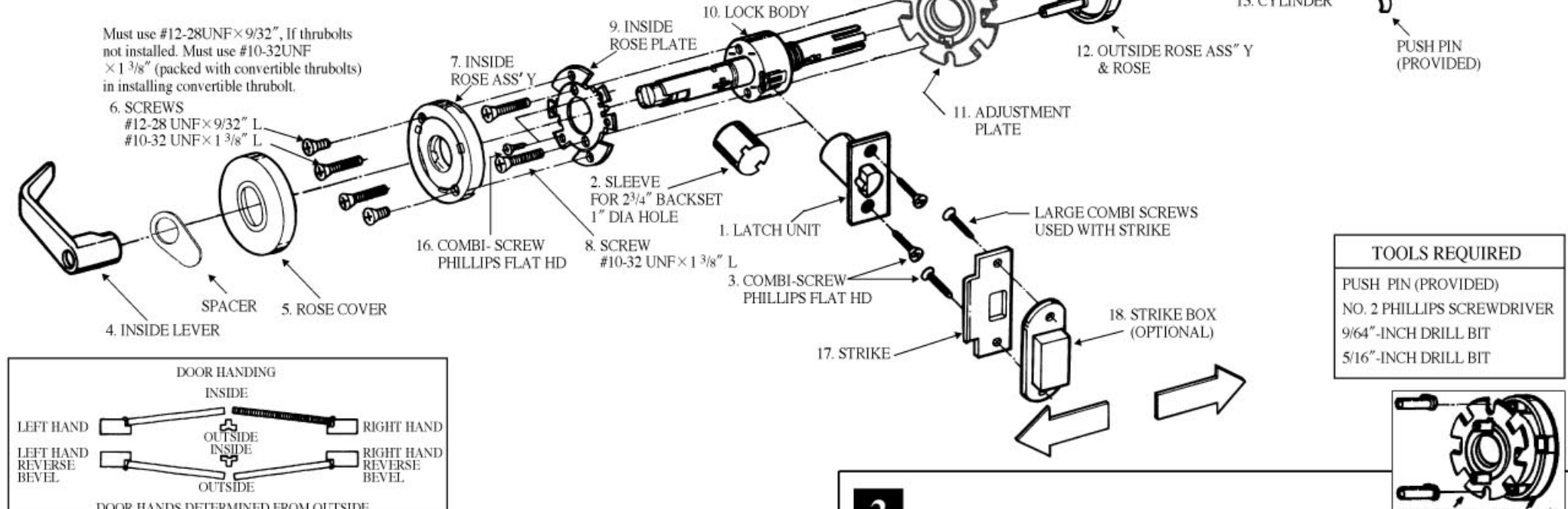

TOOLS REQUIRED
PUSH PIN (PROVIDED)
NO. 2 PHILLIPS SCREWDRIVER
9/64"-INCH DRILL BIT
5/16"-INCH DRILL BIT

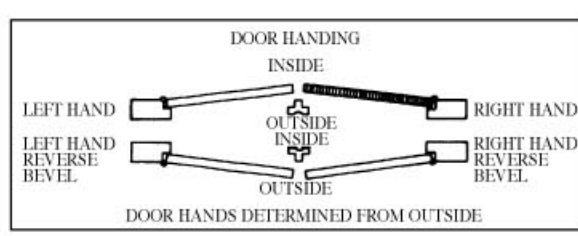

### 1 A. DOOR PREPARATION

- Check lock for proper backset and body outside stud bolt type before drilling.
- Place paper template (supplied) on door and mark for holes. Drill the cross-bore hole, and then the latch hole.
- If using thrubolts, drill two 5/16" dia holes per template.
- Mortise latch unit (1) from 5/32" into door edge to dimensions shown in fig. 2.
- Insert latch unit (1) with sleeve (2) if hole is 1" dia. or without sleeve into 7/8" dia.
- Drill two 9/64" dia. holes and secure latch unit with combi-screws (3) supplied.

### 2 B-1. DISASSEMBLY OF LOCKSET UNIT (INSIDE)

- First time removal of lever. Slide lever from tube. Discard spacer. Skip to step 3.
- To remove inside lever (4), insert push pin (provided) into hole on lever to depress the lever catch. Slide the lever from the tube.
- Remove rose cover (5) by slightly twisting counter-clockwise and pulling off.
- Remove inside rose ass'y (7)
- Remove inside rose plate (9)

**B-2. INSTALL CONVERTIBLE THRUBOLTS.**  
MAKE SURE INSTALL THRUBOLTS BEFORE LOCK INSTALLATION.

- Disassemble inside lever, rose ass'y and rose plate
- Make clearance between adjustment plate and outside rose ass'y then insert the convertible thrubolts (provided 2pcs additionally) into the cavities for convertible thrubolts in the outside rose ass'y
- Continue lock installation per instructions. Replace adjustment plate.

◆ THRUBOLTS ARE PROVIDED AND RECOMMENDED FOR USE ON HIGH FREQUENCY DOORS.

### 3 C. LOCK BODY ALIGNMENT & CENTERING

The lock body must engage the latch unit (1) prongs as shown. The lock body retractor must engage the latch unit tail piece. Door must be opened when installing lockset with guarded latch unit.

NOTE: Be sure latch unit tail piece is centered within lock body retractor. Adjust it if necessary by adjustment plate (11) as shown in fig 10 and fig 11.

### 4 D. INSTALLATION OF LOCK UNIT

- With finger, depress the latch, extending the latch unit tail piece to aid in engaging the lock body retractor (see fig 4)
- Slide lock body into cross-bore hole from exterior of the door if necessary, move tail piece slightly to engage retractor as shown in fig 4.

### 5 E. SECURING THE LOCKSET UNIT TO DOOR.

- Place the inside rose plate (9). Tighten it to lock body with two #10-32UNF×1 3/8" L screws (8)
- Drill two 9/64" dia. holes and secure the rose using two combi-screws (16)

**THIS MUST BE DONE TO FIRMLY ANCHOR LOCK TO DOOR**

### 6 F. ATTACHING INSIDE ROSE ASS'Y

- Position the inside rose ass'y's screw holes vertically with wider notch at inside diameter in line with lever catch.
- If installing without thrubolts, secure inside rose ass'y to inside rose plate with #12-28UNF×9/32" L screws (6).
- For ass'y using thrubolts, tighten inside rose ass'y to outside studs using two #10-32UNF×1-3/8" L screws.

### 7 G. INSIDE LEVER INSTALLATION

- Place rose cover (5) onto inside rose ass'y aligning two lances with recesses in rose ass'y and turn clockwise to lock as firmly as possible.
- Slide inside lever (4) onto tube. Make certain lever catch on tube is engaged with lever.

### 8 H. TO REMOVE OUTSIDE LEVER & ROSE

- To remove outside lever (13) insert key (14) and turn 45° clockwise. Insert push pin into hole on lever to depress lever catch. Slide the lever (13) from tube.
- Remove outside rose ass'y & rose (12)

NOTE: This step must be done if you have make adjustment for door thickness (See note in fig 4 & fig 11).

### 9 I. ADJUSTMENT FOR DOOR THICKNESS

It can be adjusted for door thickness range from 1 3/8" to 1 3/4". For adjustment of door thickness, follow step 8, then:

- Adjust adjustment plate (11) for proper door thickness. At final position, the screw post holes must be in line with holes in lock body.
- Slide outside rose ass'y with rose cover (12) onto tube with the wider notch at inside diameter in line with lever catch. The screw posts will enter the holes pre-aligned between adjustment plate (11) and lock body.
- Install outside lever by reversing procedure shown in fig. 10.

### 10 J. INSTALLING STRIKE

When strike box (18) is not used, recess in door jamb must be deep enough to allow latch bolt to extend to its full free length.

### 11 K. CYLINDER REMOVAL & REASSEMBLY

- Remove outside lever (13) and cylinder (15) as described in fig. 10.
- To reassemble, put a cylinder and key in lever. Push cylinder further in until it engages retractor. Turn key 90° clockwise and hold a key. Depress lever catch and push lever (Not key) in until it clicks than release a key.

LEVER HANDLE SET IS PRESET FOR 1 3/4" DOOR AT FACTORY