

Notes:

1. Do not scale drawing
2. For strike preparation refer to:
497 Strike - Template No. 7102-0003
3. Backset: 2-3/4" (70mm) standard
3-3/4" (95mm) to order
4. For wood door preparation refer to Template No. 7150-8019.
5. Door manufacturer must provide supports within the door to keep the door from collapsing when lock is installed. Back of latch case must also be supported.
6. All dimensions given in inches (mm).
7. Provide 3/4" (19) raceway for wire harness to electric hinge, location optional by door manufacture.

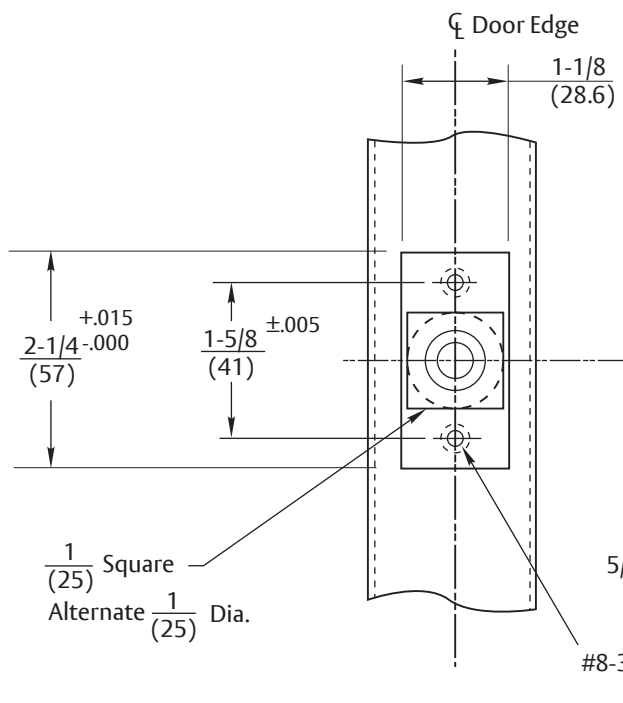
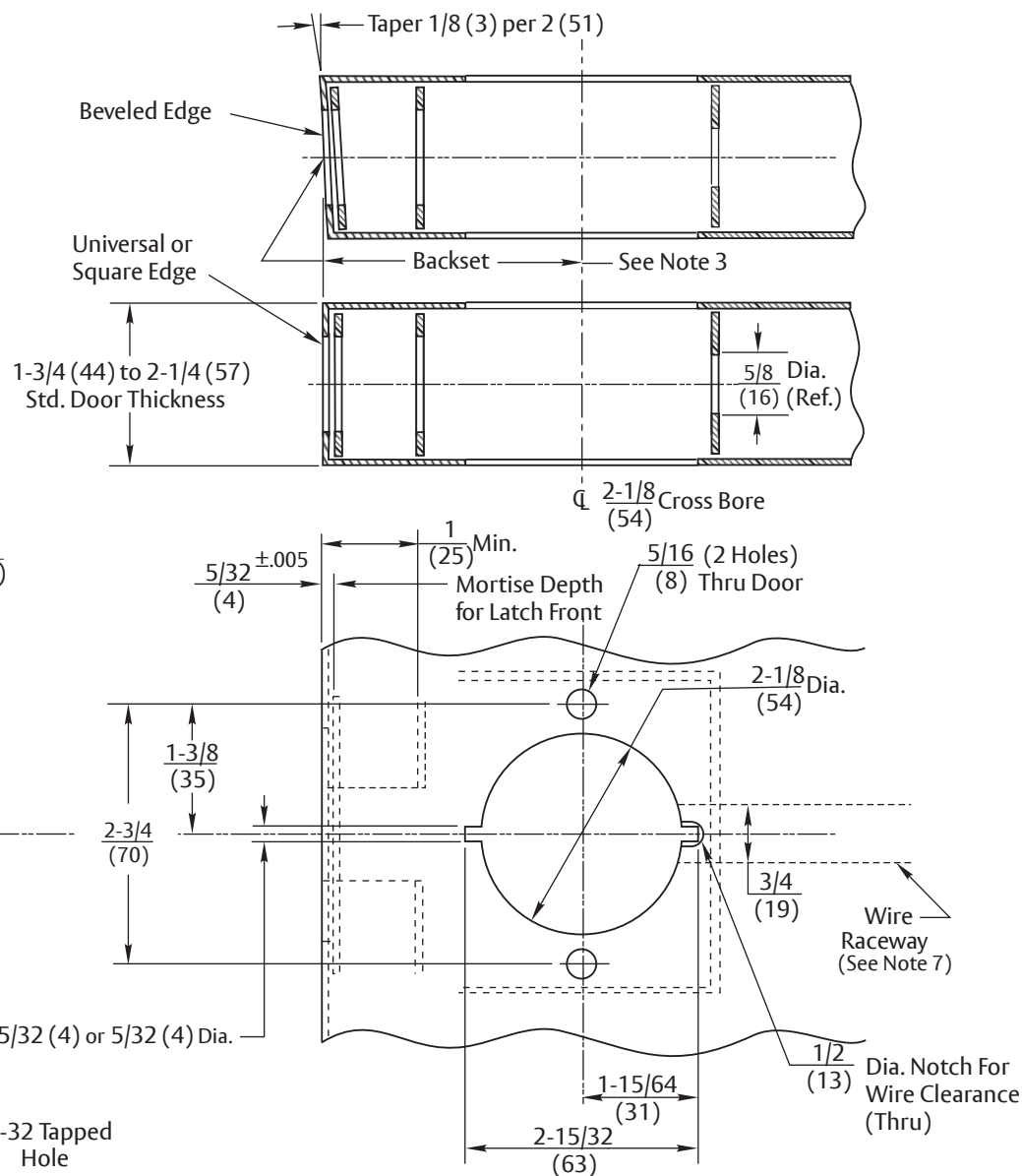

Experience a safer and more open world

Copyright © 2010, 2023, ASSA ABLOY Access and Egress Hardware Group, Inc. All rights reserved. Reproduction in whole or in part without the express written permission of ASSA ABLOY Access and Egress Hardware Group, Inc. is prohibited.

4780LN, 4781LN, 4790LN, and 4791LN
Solenoid Controlled Cylindrical Locks
 H.M. Door Preparation
 Backset - 2-3/4"(70mm) and Optional Backsets

Template Number:
7150-8018
 Sheet: 1 of 1
 Date: 12/23

ASSA ABLOY
 1-855-557-5078
 www.assaabloy.com