

Notes:

1. Do not scale drawing
2. For strike preparation refer to:
497 Strike - Template No. 7102-0003
3. Backset: 2-3/4" (70mm) standard
3-3/4" (95mm) to order
4. For H.M. door preparation refer to Template No. 7150-8018.
5. All dimensions given in inches (mm).
6. 3/8" (9.5mm) minimum raceway thru door to electric hinge, location optional by door manufacturer.

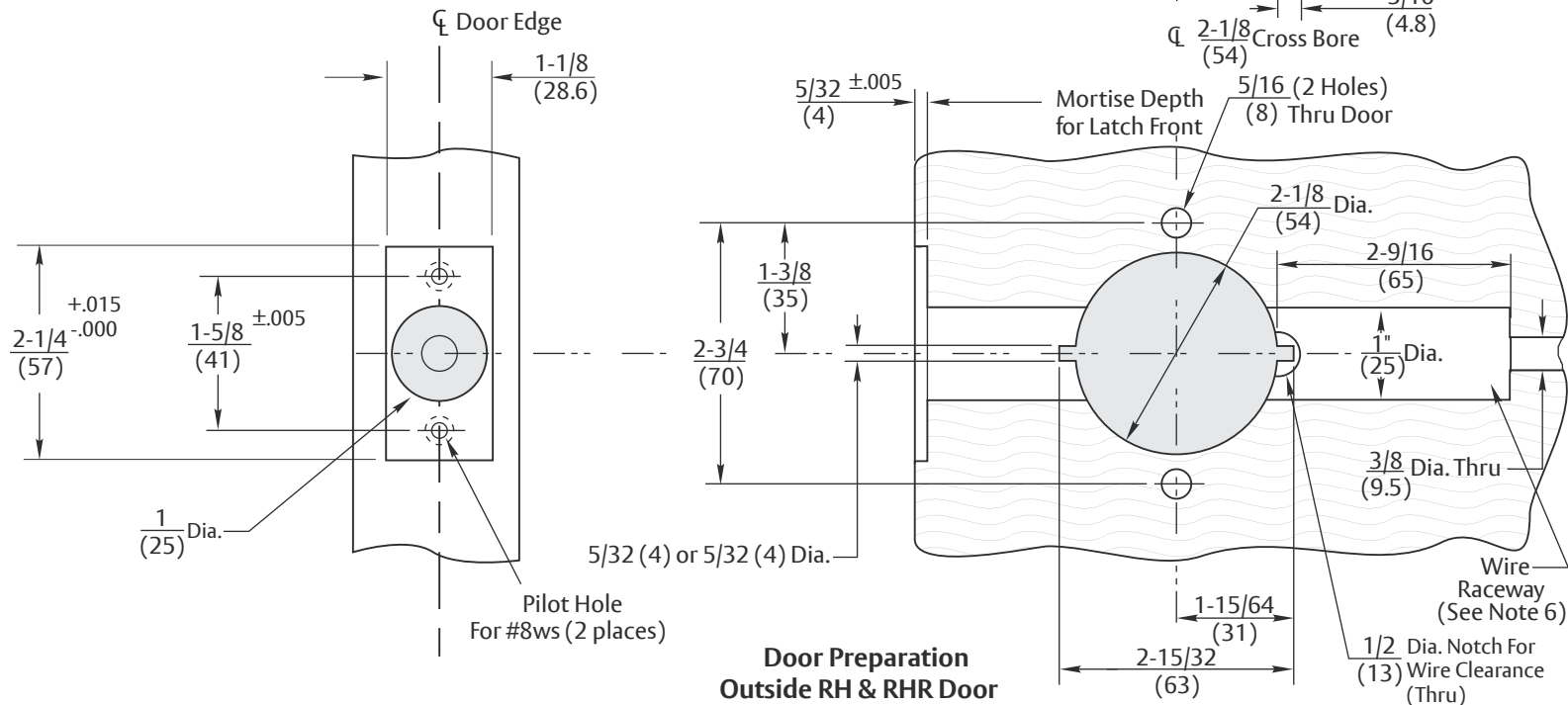
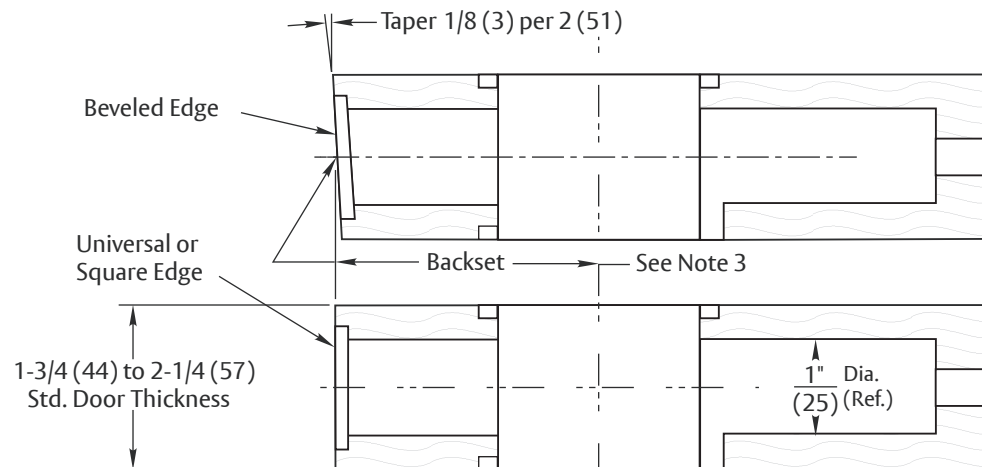

**Door Preparation
Outside RH & RHR Door**

Experience a safer
and more open world

Copyright © 2010, 2023, ASSA ABLOY Access and Egress Hardware Group, Inc. All rights reserved. Reproduction in whole or in part without the express written permission of ASSA ABLOY Access and Egress Hardware Group, Inc. is prohibited.

**4780LN, 4781LN, 4790LN & 4791LN
Solenoid Controlled Cylindrical Locks
Wood Door Preparation
Backset - 2-3/4" (70mm) and Optional Backsets**

Template Number:
7150-8019
Sheet: 1 of 1
Date: 12/23

ASSA ABLOY

1-855-557-5078
www.assaabloy.com