

Offset Pull Trim

Installation Instructions

Installation Instructions

1. Check box for contents. See previous page for components
2. After marking door inside face for device location (Device Instructions), transfer Vertical Reference Centerline from inside to outside door face. Follow steps **2a.** and **2b.** to the right.
3. Transfer Horizontal Reference Centerline from inside to outside door face.
4. Align trim template and tape 4. to outside door face.
5. Spot holes and prepare door for trim.
6. For 480F & 482F Trim: Mount trim to door thru holes "A" with (2) mounting screws as shown in **Fig. 1**
7. For 481F & 483F Nightlatch Trim: Cut trim tailpiece as shown in **Fig. 2**. Seat device so that the trim tailpiece penetrates cam slot as shown in **Fig. 1**. Mount trim to door thru holes "A" as shown in **Fig. 1**.
8. Continue as shown in device instructions.

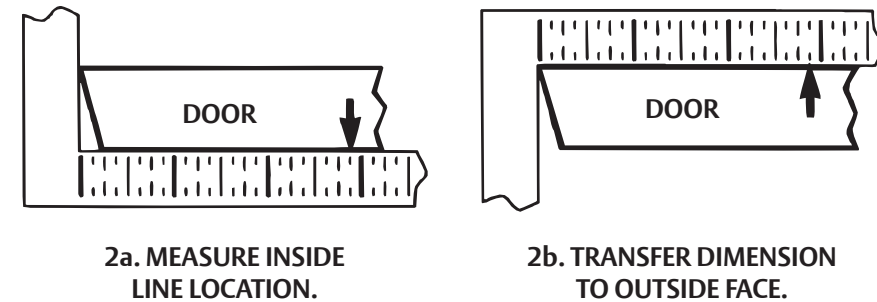

For use with 7200 Series Exit Device (Wood and Metal Doors)

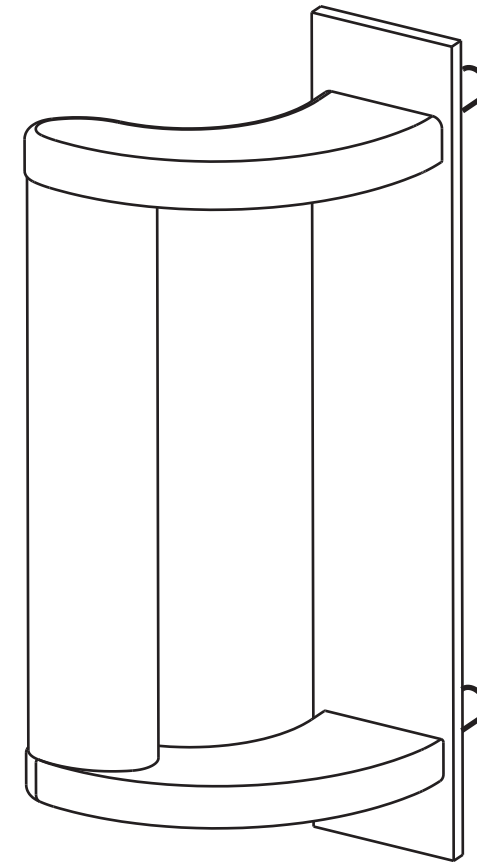

**480F & 482F
Offset Pull Trim
Non-Handed**

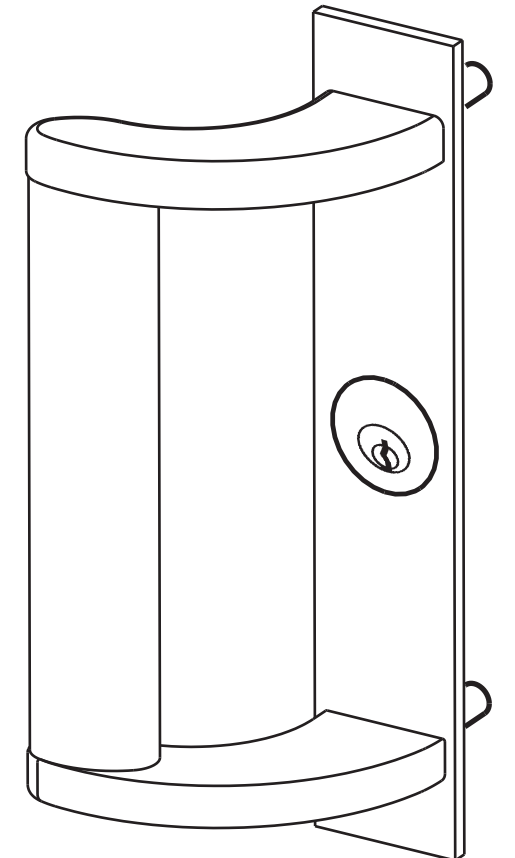

**481F & 483F
Nightlatch Function
Offset Pull Trim
Handed - LHR Shown**

Figure 1

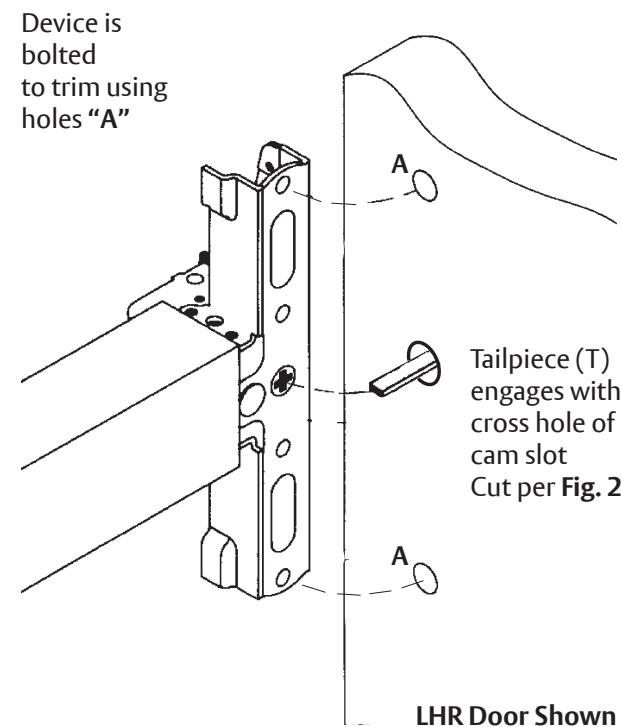
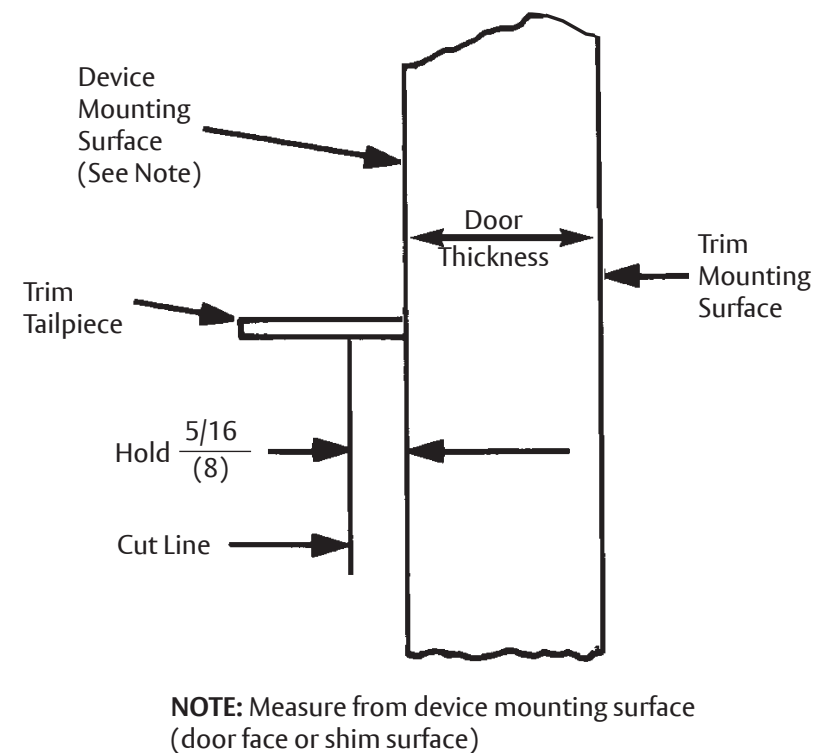

Figure 2 481 Nightlatch Tailpiece Sizing



⚠ WARNING

This product can expose you to lead which is known to the state of California to cause cancer and birth defects or other reproductive harm. For more information go to www.P65warnings.ca.gov.

⚠ WARNING

Attention Installer: Any retrofit or other field modification to a fire rated opening can potentially impact the fire rating of the opening, and ASSA ABLOY makes no representations or warranties concerning what such impact may be in any specific situation. When retrofitting any portion of an existing fire-rated opening, or specifying and installing a new fire-rated opening, please consult with a code specialist or local code official (Authority Having Jurisdiction) to ensure compliance with all applicable codes and ratings.

Outside Door Face Trim Template

(7-1/2" Escutcheon)

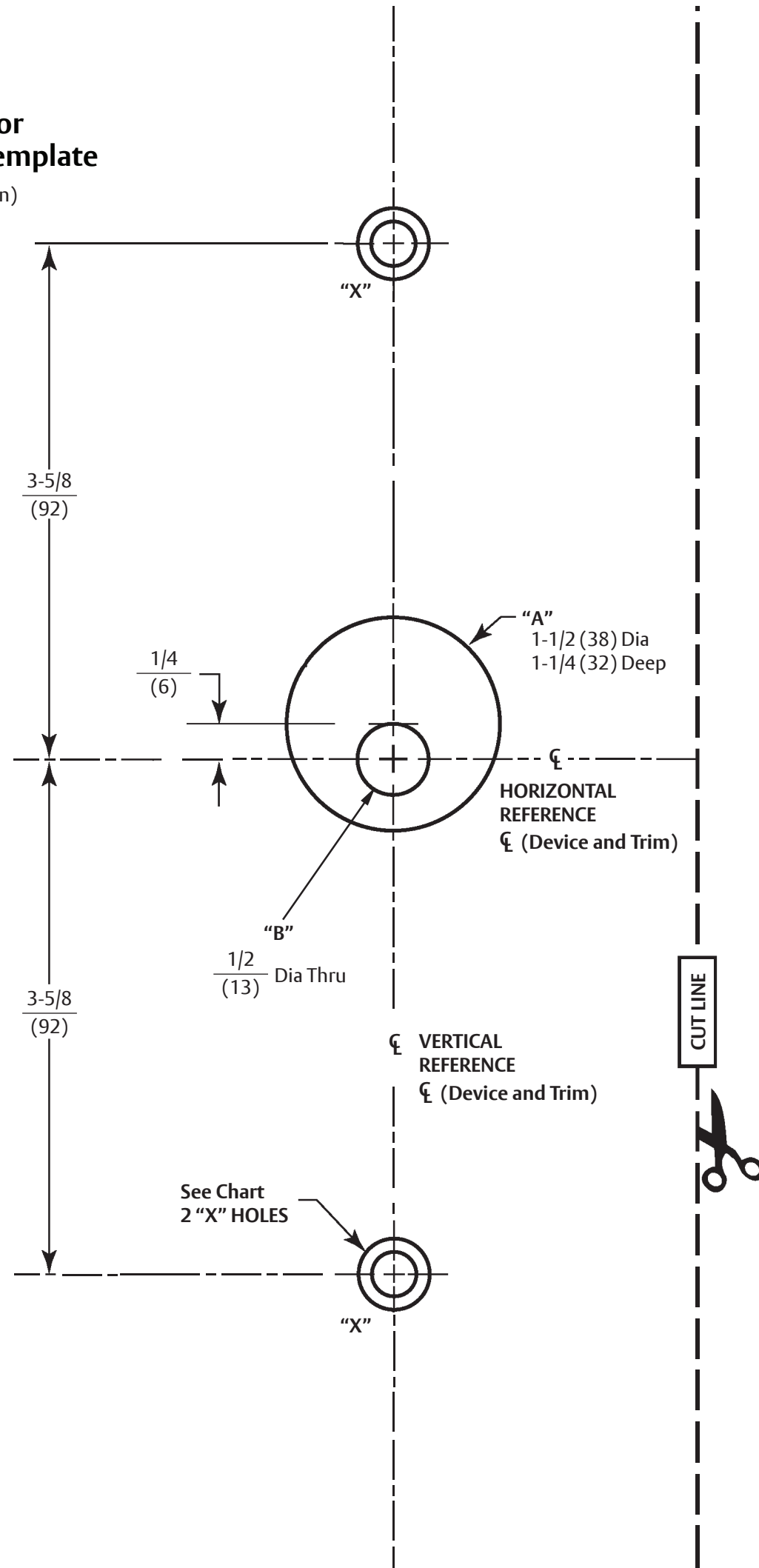

TRIM	HOLES
480F	X
481F	A, B, X
For Holes Marked "X" See Below	
METAL DOORS: Inside Face 5/16" (8) Dia. Outside Face 1/2" (13) Dia.	
WOOD DOORS: 1/2" (13) Dia. Thru	

Dimensions given in inches (mm)

CAUTION: Office copiers, printers and facsimile machines may change the size of a drawing and make the template inaccurate to use as a door marker.

Trim Assembly Instructions

1. **Check cylinder components.**
NOTE: Refer to ASSA ABLOY cylinder chart in catalog for collar sizing.
2. **Assembly cylinder.**
Insert cylinder housing prongs into matching notches of escutcheon. Pass cylinder tailpiece thru cylinder collar (when required) and hole in cylinder housing. Fasten cylinder using (2) mounting screws. **DO NOT OVERTIGHTEN SCREWS.**

481F & 483F Nightlatch Function Offset Pull Trim

Left Hand Reverse Shown: To change handing, remove posts labled "A" and rotate Handle Assembly 180°.

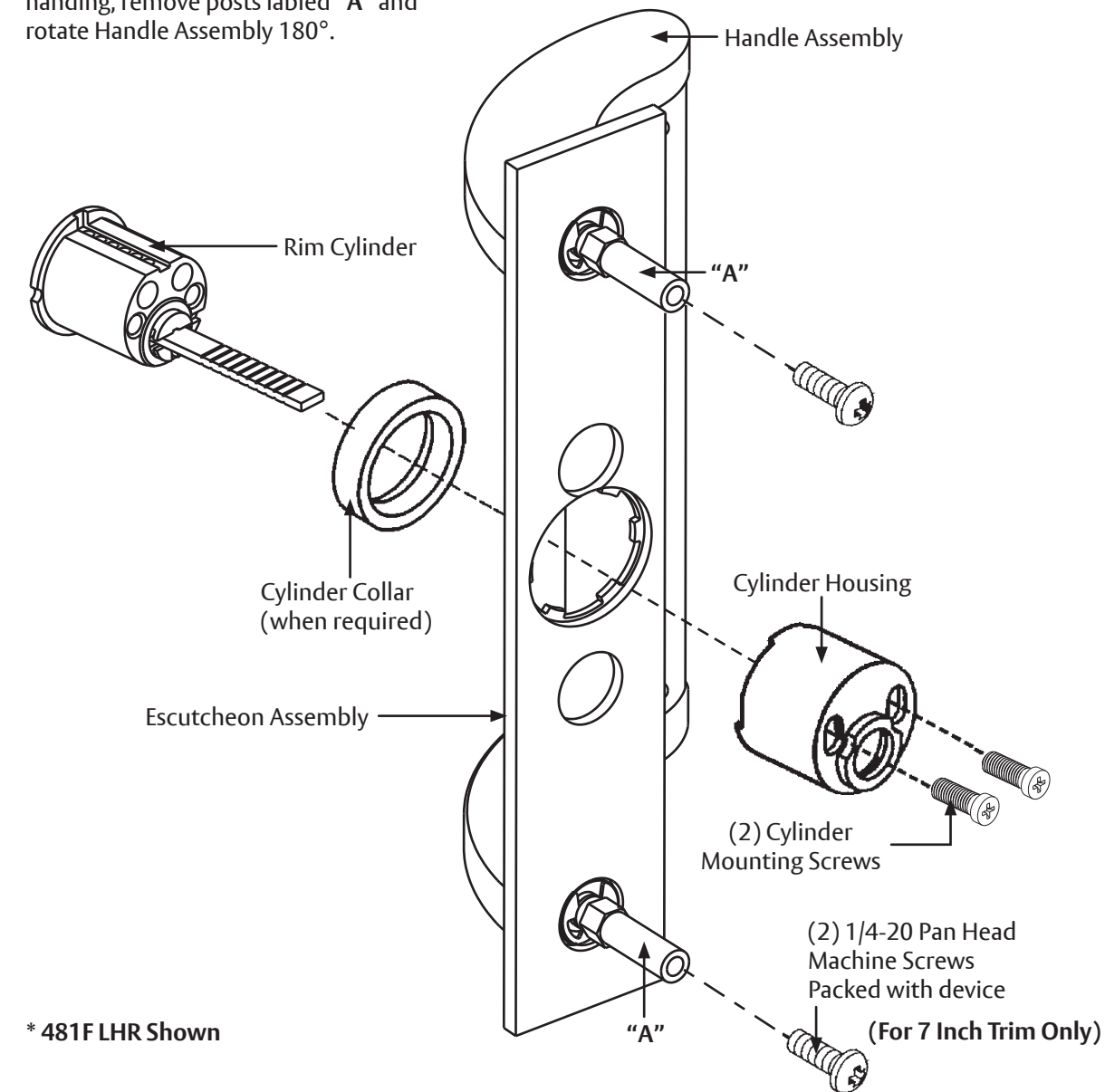

480F & 482F Offset Pull Trim

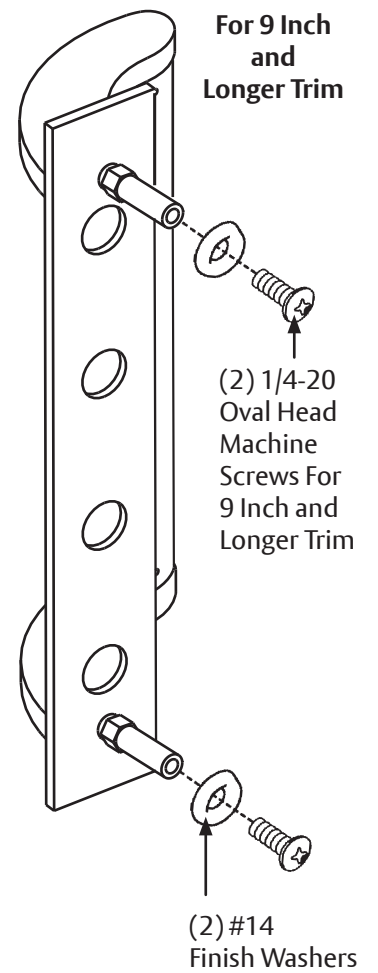

* 481F LHR Shown

* 482F LHR Shown

Outside Door Face Trim Template

(9" Escutcheon)

CAUTION:
Office copiers, printers and facsimile machines may change the size of a drawing and make the template inaccurate to use as a door marker.

TRIM	HOLES
482F-9	X
483F-9	A, B, X
For Holes Marked "X" See Below	
METAL DOORS: Inside Face 5/16" (8) Dia. Outside Face 1/2" (13) Dia.	
WOOD DOORS: 1/2" (13) Dia. Thru	

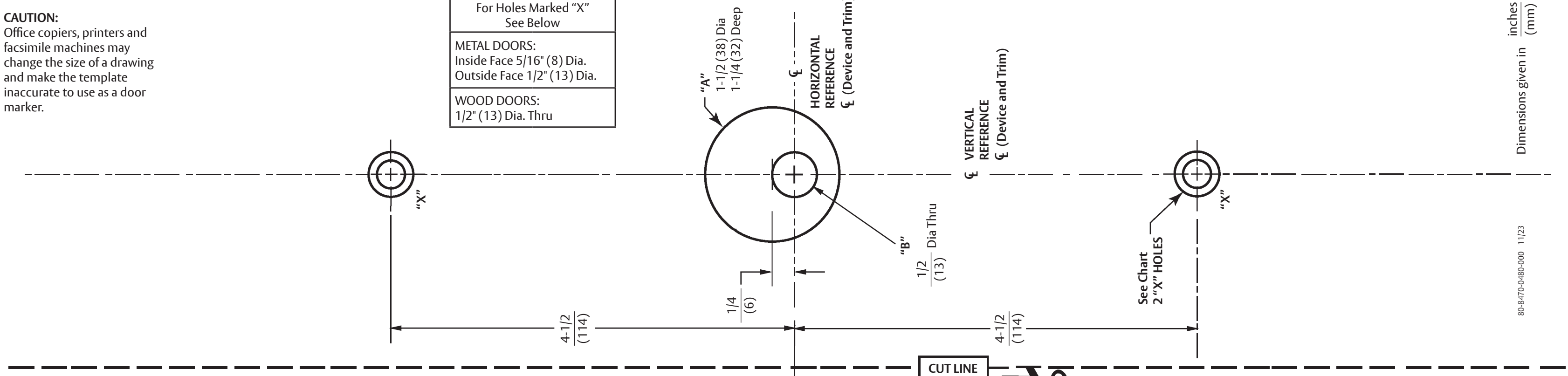

Dimensions given in inches (mm)

80-8470-0480-000 11/23

Outside Door Face Trim Template

(15" Escutcheon)

CAUTION:
Office copiers, printers and facsimile machines may change the size of a drawing and make the template inaccurate to use as a door marker.

TRIM	HOLES
482F-9	X
483F-9	A, B, X
For Holes Marked "X" See Below	
METAL DOORS: Inside Face 5/16" (8) Dia. Outside Face 1/2" (13) Dia.	
WOOD DOORS: 1/2" (13) Dia. Thru	

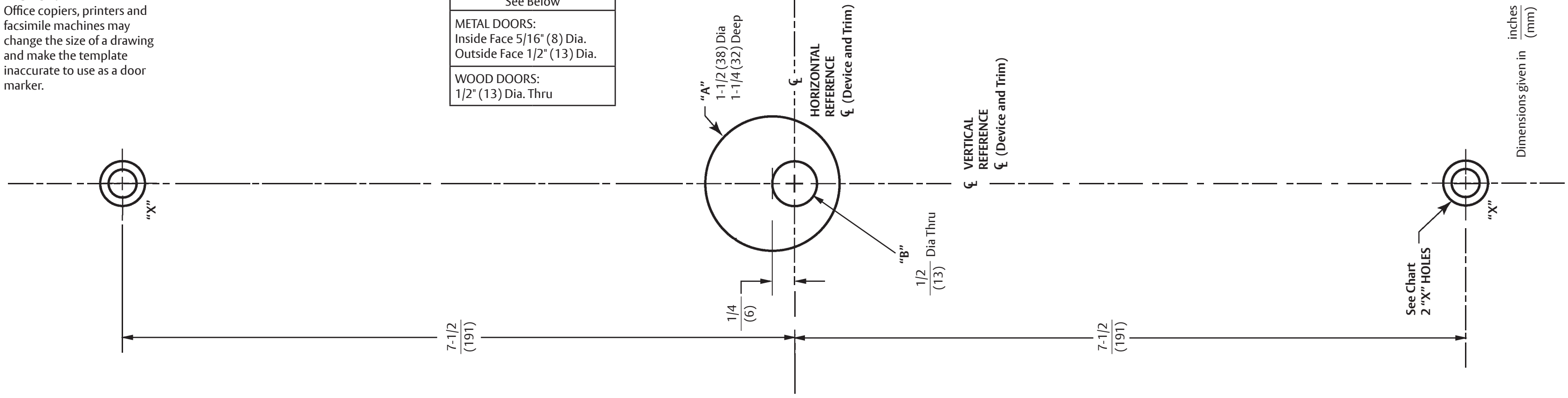

Dimensions given in inches (mm)

Outside Door Face Trim Template

(18" Escutcheon)

CAUTION:
Office copiers, printers and facsimile machines may change the size of a drawing and make the template inaccurate to use as a door marker.

TRIM	HOLES
482F-9	X
483F-9	A, B, X
For Holes Marked "X" See Below	
METAL DOORS: Inside Face 5/16" (8) Dia. Outside Face 1/2" (13) Dia.	
WOOD DOORS: 1/2" (13) Dia. Thru	

