

**NOTES:**

1. Do not scale drawing.
2. Left hand door shown.
3. Dimensions given in inches (millimeters).
4. Door swing may be limited by door, frame, wall or hardware conditions.
5. Hollow metal doors require channel or box type reinforcement when thru-bolt mount is specified.
6. Sleeve nuts and bolts may be required for wood or plastic faced fire door mounting.
7. Minimum thickness recommended for reinforcements in hollow metal doors and frames: .1046" (2.66mm) unless otherwise noted.
8. Hold open arm door closers are not permitted for use on fire rated doors.

Opening	Dimension "A"	Reveal	Models
To 100°	7-1/2 (191)	0 to 3" (0 to 76)	51
101° to 120°	6 (152)	2-7/8" to 7" (73 to 178)	TJ51
121° to 180°	3-1/2 (89)	0 to 2-3/4" (0 to 70)	151
		2-3/4" to 6-3/4" (70 to 171)	TJ151

**Position of Arm and Pinion Flat**

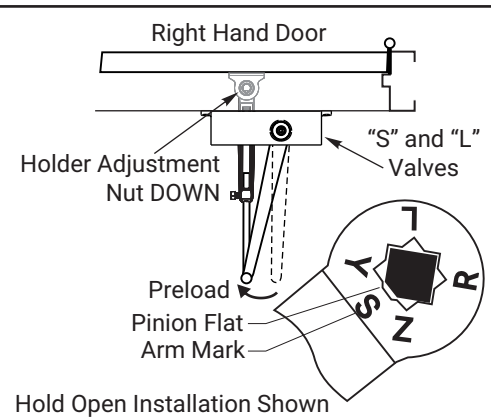
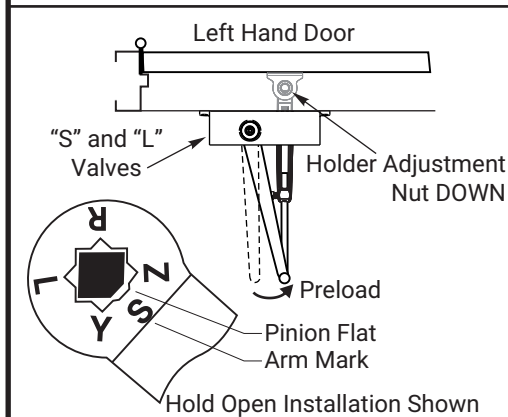

Fastener	Door or Frame	Drill
#14 type "A" sheet metal screw	wood	7/32" (5.5mm)
1/4-20 machine screw	metal	#7 (.201" dia.) or 5.10mm drill 1/4"-20 tap
SNB (optional)	hollow-metal	9/32" (7.00mm) thru 3/8" (9.50mm) door face opposite to closer
	aluminum or wood	3/8" (9.50mm) thru
TBGN (optional)	all	9-32" (7.00mm) thru 3/8" (9.50mm) diameter x 3/8" (10mm) deep, door face opposite to closer

**50 Series Door Closers  
Models (TJ)51 and (TJ)151  
Top Jamb Application, Non-Hold Open or Hold Open  
Multi-size Unit 1-6**

**ACCENTRA**  
**ASSA ABLOY**

TEMPLATE NUMBER	REV	DATE
7350-1152	3	05/24