

# 501F & 512F

## Trim

### Installation Instructions

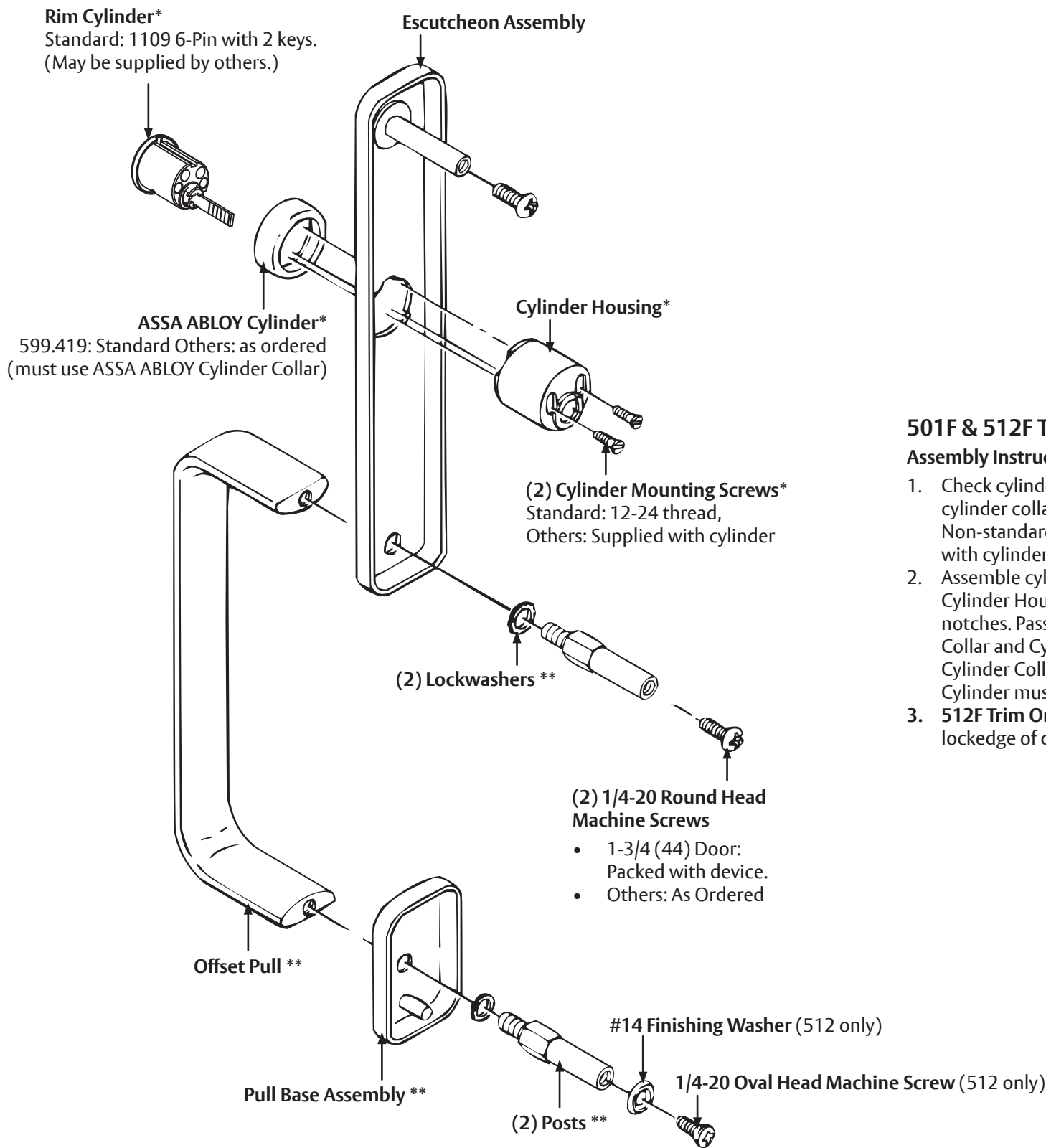

### 501F & 512F Trim

#### Assembly Instructions

1. Check cylinder components. See Chart. Non-standard cylinder collars should be identified on product order. Non-standard cylinder mounting screws are supplied with cylinders.
2. Assemble cylinder, use components marked (\*). Insert Cylinder Housing prongs into Escutcheon matching notches. Pass Cylinder tailpiece thru ASSA ABLOY Cylinder Collar and Cylinder Housing. Bolt Cylinder seated in Cylinder Collar recess (DO NOT OVERTIGHTEN SCREWS). Cylinder must now work freely.
3. **512F Trim Only:** Assemble pull, offset away from locked of door. Use components marked (\*\*).

#### 599.419 CYLINDER COLLAR APPLICATIONS

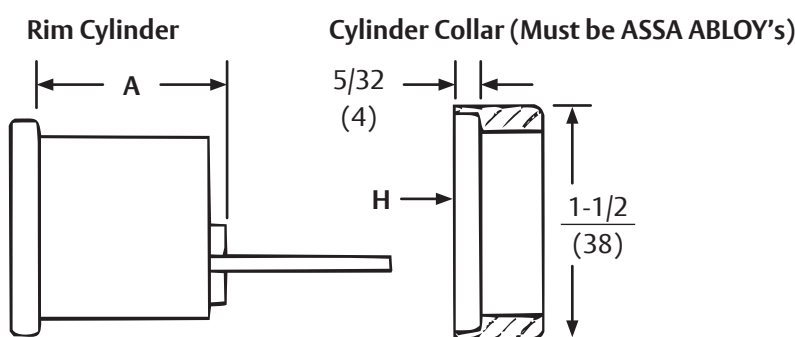

Collar Number	Collar Dim. "H"
599.419	19/32" (15)

Cylinder Length (Dim "A")	Cylinder Collar	ASSA ABLOY Cylinder	Cylinder Mounting Screws
Up to 1-9/16" (39)	599.419 (Std.)	6-Pin, Fixed Core	60-7000-1235-048 (Std.)
		7-Pin, Fixed Core	

For other cylinder types, refer to 7000 Series Exit Device catalog for collar information.

All dimensions are in inches (mm).

#### ⚠ WARNING

This product can expose you to lead which is known to the state of California to cause cancer and birth defects or other reproductive harm. For more information go to [www.P65warnings.ca.gov](http://www.P65warnings.ca.gov).

#### ⚠ WARNING

Attention Installer: Any retrofit or other field modification to a fire rated opening can potentially impact the fire rating of the opening, and ASSA ABLOY makes no representations or warranties concerning what such impact may be in any specific situation. When retrofitting any portion of an existing fire-rated opening, or specifying and installing a new fire-rated opening, please consult with a code specialist or local code official (Authority Having Jurisdiction) to ensure compliance with all applicable codes and ratings.



DOOR  
OUTSIDE FACE

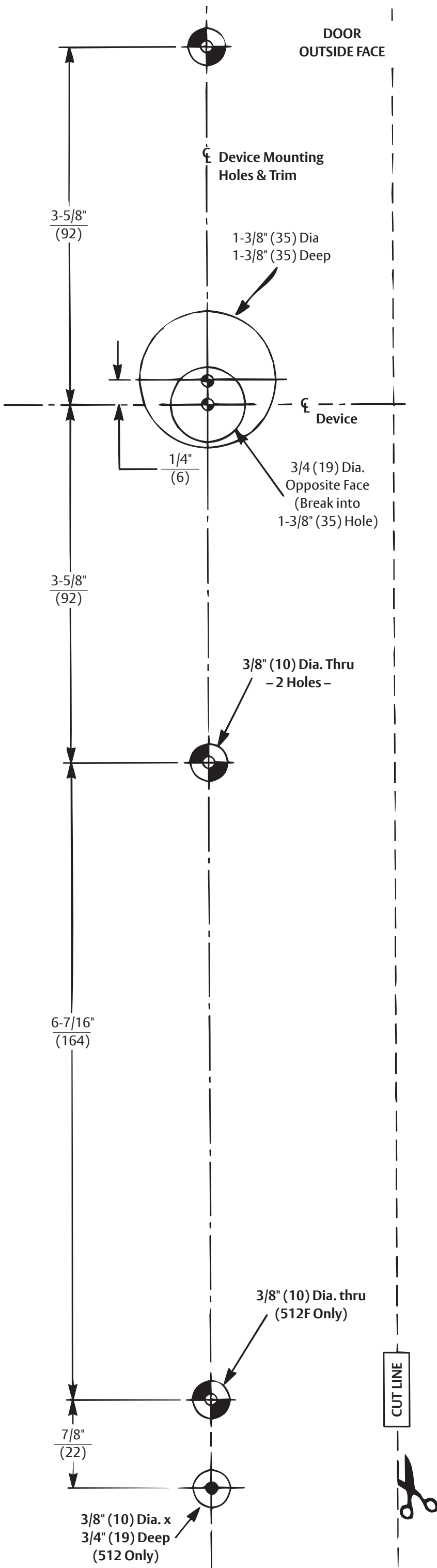

## Installation Instructions

1. Pull trim becomes handed after assembly (parts are universal). See other side for components and instructions.
2. After marking door inside face for device location (Device Instructions), carry "Centerline of Device Mounting Holes" from outside doorface. **Follow steps 2a and 2b, below.**
3. Carry horizontal "Centerline of Device" from inside to outside door face.
4. Align trim template and tape to door, outside face.  
**Caution:** Office copiers and facsimile machines may change the size of a drawing and make the template inaccurate to use as a door marker. If this is not the original template packed with the trim, use only the dimensions written on the template to locate the holes on the door (do not use the template as a door marker).
5. Spot holes and prepared door for trim.
6. Mount trim to door. Fasten finger tight with 2 screws (packed with device). see **Figure 2**.
7. With trim unlocked (tailpiece turning when the thumbturn is rotated or the thumbpiece is depressed), cut trim tailpiece as shown in **Figure 1**.
8. Seat device so that trim tailpiece penetrates cam slot, as shown in **Figure 2**. Continue as shown in device instructions. Bottom pull post fastens to door, with oval head screw seated on countersunk washer (packed with trim).

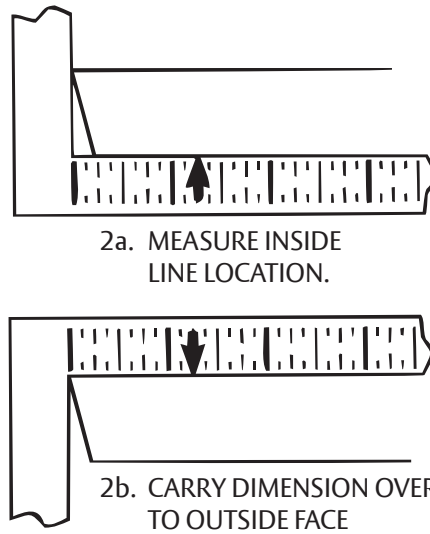

**Figure 1.**  
Device Mounting Surface  
(See Note)

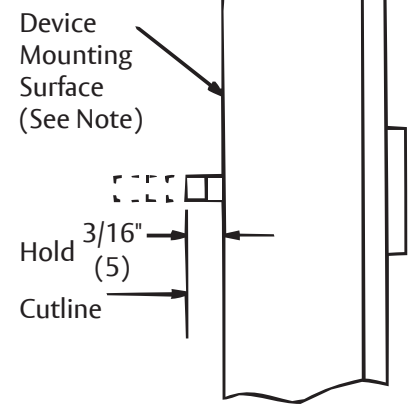

**NOTE:** Measure from device seat (door face — shown — or shim surface)

**Figure 2.**

(2) Device mounting screws bolt trim to device. Use also to bolt trim to door, for measuring trim tailpiece.

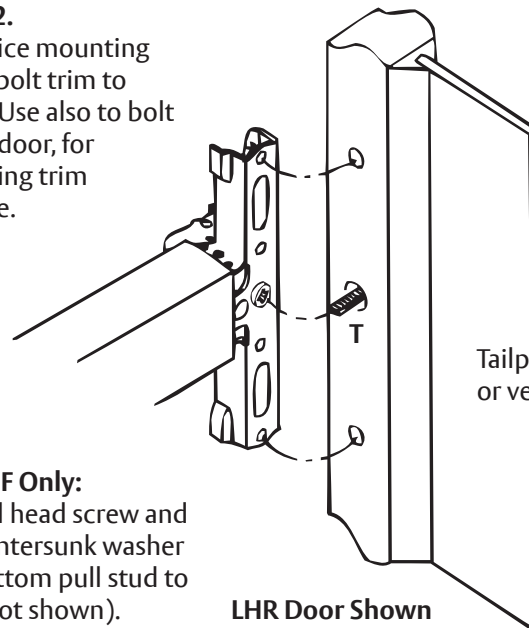

### For 512F Only:

(1) Oval head screw and (1) countersunk washer bolt bottom pull stud to door (not shown).

### Cylinder x Escutcheon

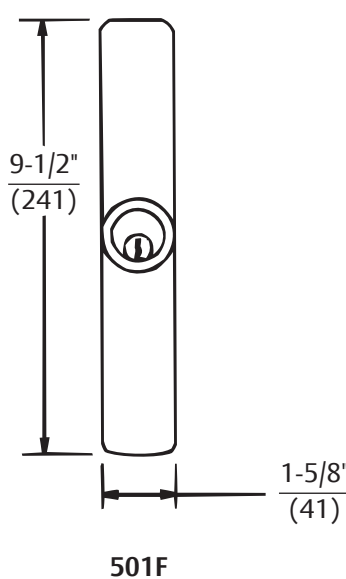

### Blank Escutcheon x Offset Pull

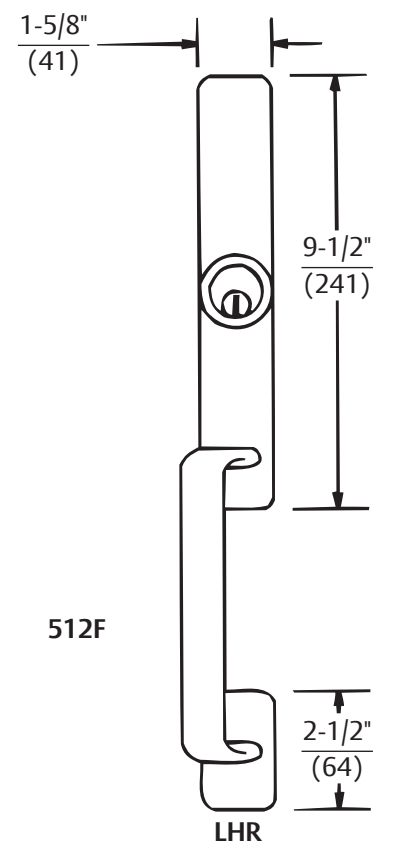

**F03 Trim:**  
Cylinder retracts device latchbolt(s)

Dimensions given in  $\frac{\text{inches}}{\text{mm}}$

