

Notes:

1. This template is an addition to the device template. Locate centerlines using horizontal and vertical references on device template.
2. Do not scale drawing
3. Dimensions are in inches (mm).
4. LHR door shown. Preparation is typical for both door hands.
5. For door reinforcement see template 7400-0000.
6. Prepare mounting holes when installing the trim.
7. Provide internal door support door deformation from bolting trim to the device

Hole	Specification
A	3/8(9.50) Dia. Outside Face 5/16(8) Dia. Inside Face (3 Places)
B	3/8(9.50) Dia. Outside Face

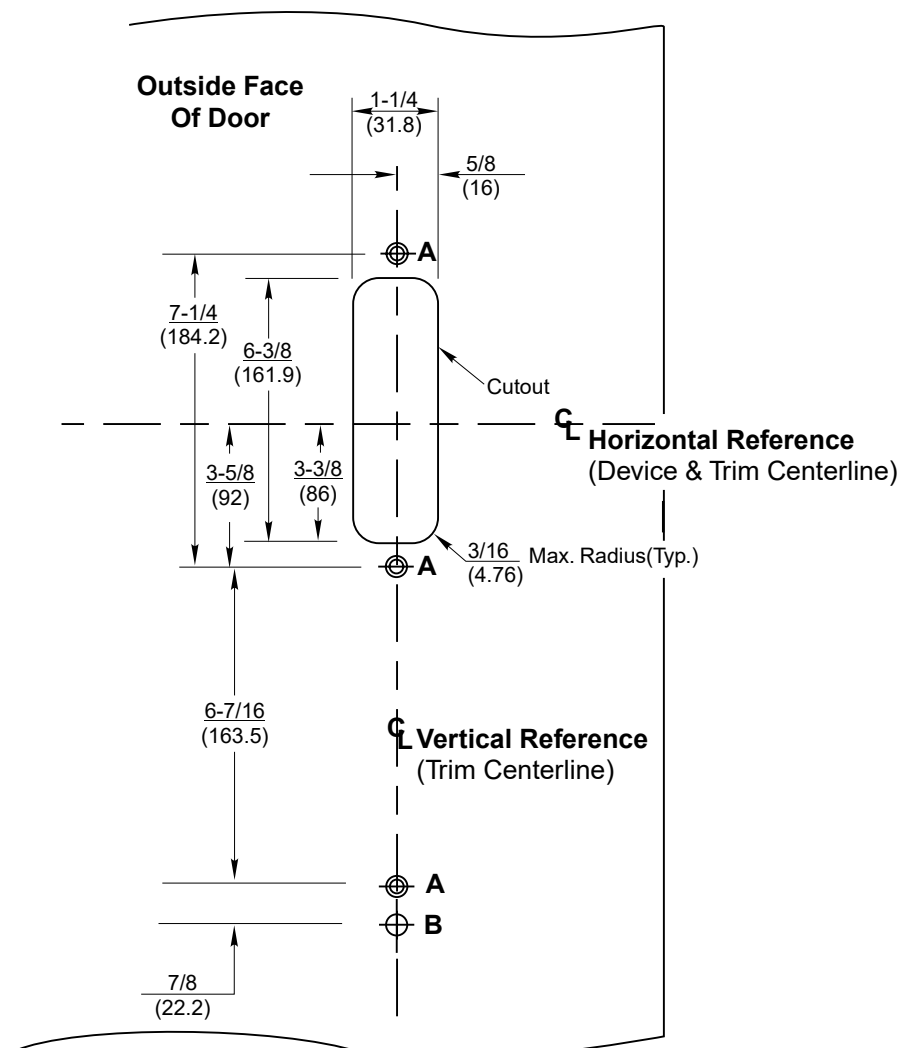
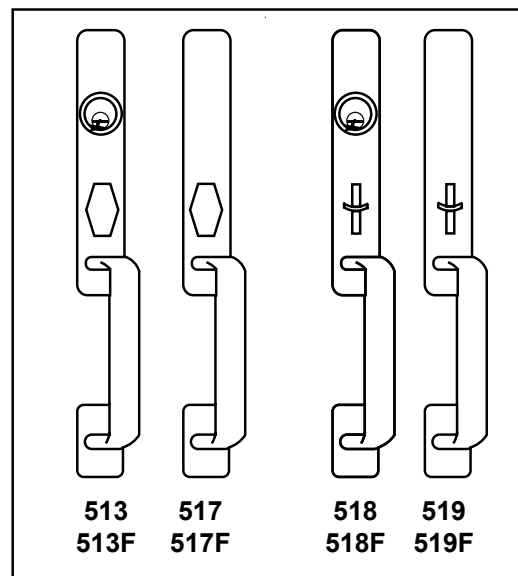

RESPONSIBILITY

DOOR AND FRAME MANUFACTURERS ARE RESPONSIBLE FOR PROVIDING ADEQUATE CONSTRUCTION OR REINFORCEMENTS FOR PROPER INSTALLATION OF HARDWARE SHOWN. ALL ARCHITECTURAL BUILDERS HARDWARE MUST BE INSTALLED ON PROPERLY REINFORCED DOORS AND FRAMES, REGARDLESS OF TYPE, MATERIAL, OR METHOD OF CONSTRUCTION.

513(F),517(F),518(F) and 519(F)  
Narrow Escutcheon Trim  
With 7200, 7200M or 7200MF Series  
Rim and Vertical Rod Exit Devices  
Metal Door Preparation

Contact us for support at 1-855-557-5078.

**ASSA ABLOY**

SUPERSEDES 7400-0513 08/99	DO NOT SCALE DRAWING	
TEMPLATE NUMBER	7400-0513	DATE 01-24