

Backset	1/2" Throw		5/8" Throw		3/4" Throw	
	Latch No.	Link No.	Latch No.	Link No.	Latch No.	Link No.
$\frac{2-3}{4}$ (70)	493 or 494	-	478 or 480	-	478A or 480B	-
$\frac{3-3}{4}$ (95)	3493 or 3494	-	3478 or 3480	-	3478A or 3480B	-
$\frac{5}{7}$ (127)	493 or 494	481	478 or 480	481	478A or 480B	481
$\frac{6}{7}$ (152)	3493 or 3494	481	3478 or 3480	481	3478A or 3480B	481
$\frac{7}{7}$ (178)	493 or 494	482	478 or 480	482	478A or 480B	482
$\frac{8}{7}$ (203)	3493 or 3494	482	3478 or 3480	482	3478A or 3480B	482
$\frac{18}{7}$ (457)	493 or 494	484	478 or 480	484	478A or 480B	484
$\frac{19}{7}$ (483)	3493 or 3494	484	3478 or 3480	484	3478A or 3480B	484

DO NOT SCALE

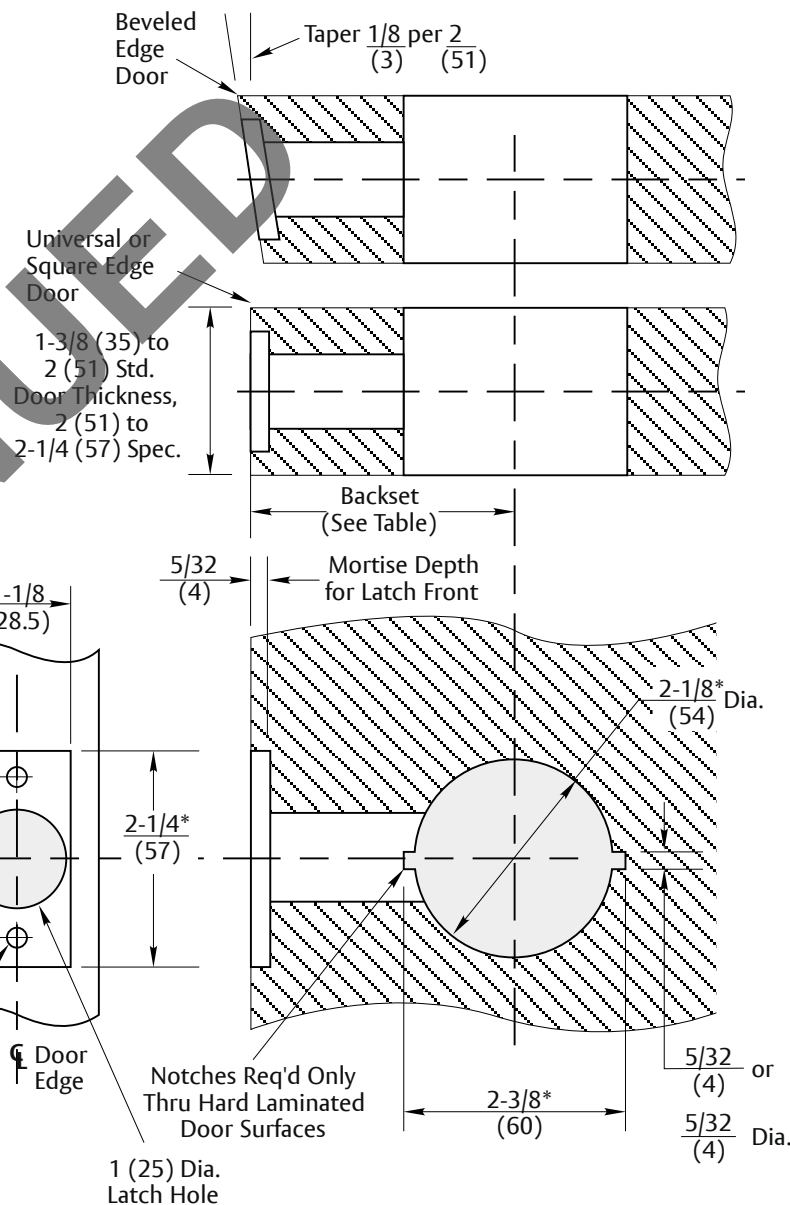

Notes:

1. When ANSI A115.2 (Fig. 1) Strike is specified, refer to No. 497 Strike, Template No. 7102-0003.
2. When ANSI A115.2 (Fig. 2) Strike is specified, refer to No. 495 Strike, Template 7102-0005.
3. Dimensions marked with * have tolerances of +1/32, -0.
4. All dimensions given in inches (mm).

Experience a safer and more open world

Copyright © 2023, ASSA ABLOY Access and Egress Hardware Group, Inc. All rights reserved. Reproduction in whole or in part without the express written permission of ASSA ABLOY Access and Egress Hardware Group, Inc. is prohibited.

5400 & 5500 Series Cylindrical Locks (Knob Trim)
Wood Door Preparation (ANSI A115.2) (FIG. 1)
2-3/4" and Optional Backsets

Template Number:
7150-0059
Sheet: 1 of 1
Date: 12/23

ASSA ABLOY

1-855-557-5078
www.assaabloy.com