

5400LN SERIES Key-In Lever Cylindrical Locks				
Backset	1/2" Throw		3/4" Throw	
	Latch No.	Link No.	Latch No.	Link No.
2-3/4 (70)	693 or 694	-	480B	-
3-3/4 (95)	3693 or 3694	-	3480B	-
5 (127)	693 or 694	481DL	480B	481DL
6 (152)	3693 or 3694	481	3480B	481
7 (178)	693 or 694	482	480B	482
8 (203)	3693 or 3694	482	3480B	482
18 (457)	693 or 694	484	480B	484
19 (483)	3693 or 3694	484	3480B	484

Notes:

- For strike preparation refer to:
495 Strike - Template No. 7102-0005
497 Strike - Template No. 7102-0003
- The 5400LN locks can be installed on 1-3/8" (35mm) thick doors by using two (2) #14-5401-6644 spacers under the inside and outside roses.
- For HM door preparation refer to Template No. 7150-0056.
- All dimensions given in inches (mm).
- For universal or square edge doors use latchbolts with flat front (i.e. F694, F480B, etc.)
- Dimensions marked with * have tolerances of +1/32, -0.

DO NOT SCALE

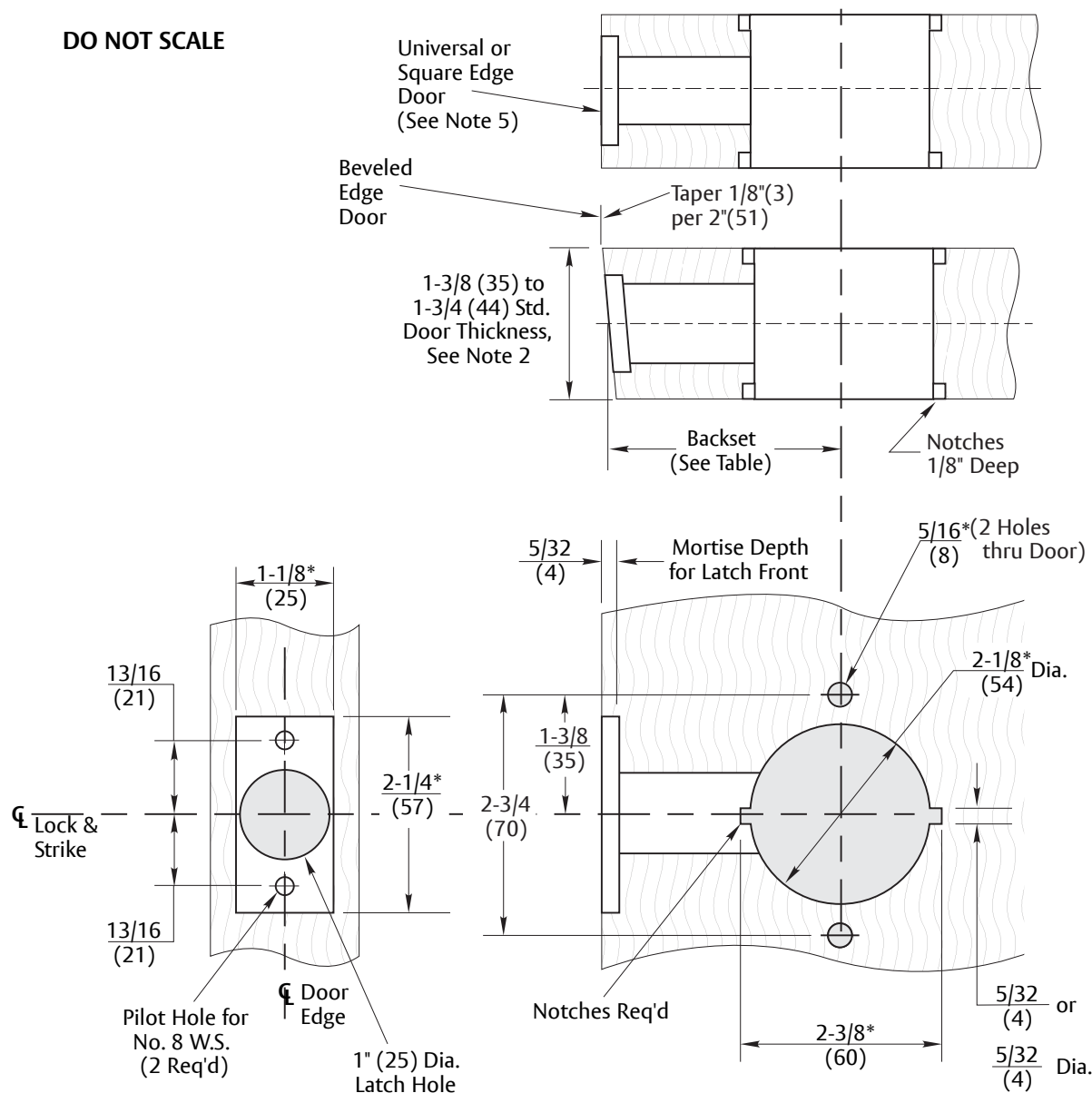

Experience a safer
and more open world

Copyright © 2008, 2023, ASSA ABLOY Access and Egress Hardware Group, Inc. All rights reserved. Reproduction in whole or in part without the express written permission of ASSA ABLOY Access and Egress Hardware Group, Inc. is prohibited.

5400LN Series Key-In-Lever Cylindrical Locks -
1-1/8" Wide Front
Wood Door Preparation (See ANSI/BHMA A156.115)
2-3/4" and Optional Backsets

Template Number:
7150-0057
Sheet: 1 of 1
Date: 12/23

ASSA ABLOY

1-855-557-5078
www.assaabloy.com