

603F Series

ASSA ABLOY

Heavy Duty Trim

Installation Instructions

For use with all ASSA ABLOY®
7000, 2100, 1800 and 1500 Series
Exit Devices (Wood and Metal
Doors)

603F Series
Non-Handed

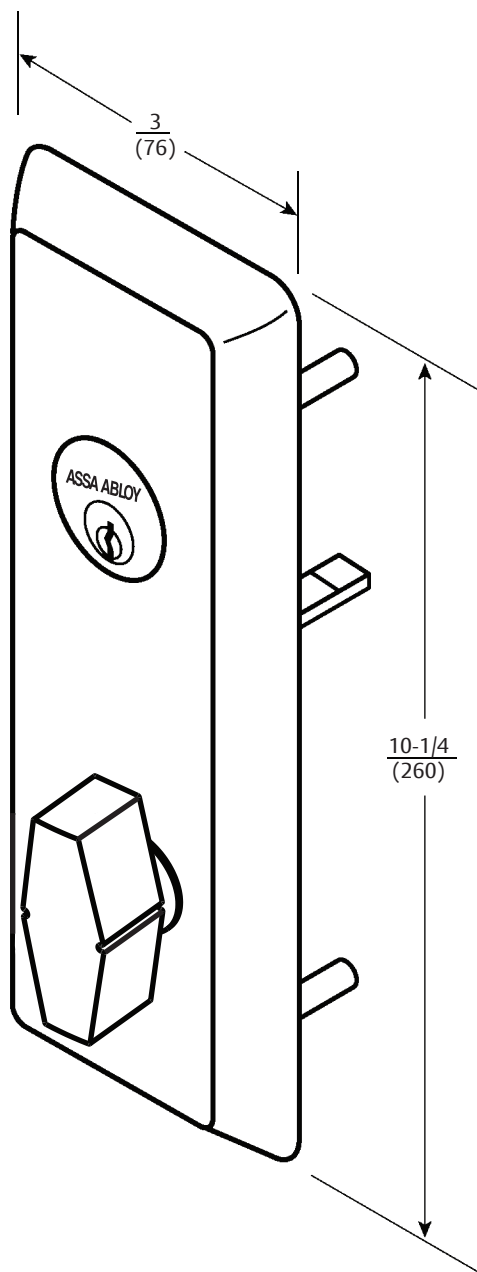

WARNING

This product can expose you to lead which is known to the state of California to cause cancer and birth defects or other reproductive harm. For more information go to www.P65warnings.ca.gov.

WARNING

Attention Installer: Any retrofit or other field modification to a fire rated opening can potentially impact the fire rating of the opening, and ASSA ABLOY makes no representations or warranties concerning what such impact may be in any specific situation. When retrofitting any portion of an existing fire-rated opening, or specifying and installing a new fire-rated opening, please consult with a code specialist or local code official (Authority Having Jurisdiction) to ensure compliance with all applicable codes and ratings.

80-8470-0603-000 03/24

1-800-438-1951 • www.assaabloy.com

Copyright © 2013, 2023, 2024, ASSA ABLOY Access and Egress Hardware Group, Inc. All rights reserved. Reproduction in whole or in part without the express written permission of ASSA ABLOY Access and Egress Hardware Group, Inc. is prohibited.

Experience a safer
and more open world

Trim Assembly Instructions

1. Check cylinder components.

NOTE: Cylinders longer than 1-1/8" (29) will require collars. Refer to cylinder collar chart.

2. When required, cut cylinder tailpiece.

3. Assemble cylinder.

Insert cylinder housing prongs into matching notches of escutcheon. Pass cylinder tailpiece thru cylinder collar (when required) and slot in cylinder housing cam. Fasten cylinder using (2) mounting screws. **DO NOT OVER TIGHTEN SCREWS.** See Double Cylinder detail below.

4. Check cylinder action.

Rotate cylinder tailpiece to cam the clutch lever down. This depresses the trim spindle assembly which disengages the trim spindle from the lever handle, putting the trim in a free-wheeling, locked mode.

Cylinder Collar Chart	
Cylinder Length	Cylinder Length
1-1/8" (29)	None
1-1/4" (32)	**
1-1/2" (38)	**

**Specify finish

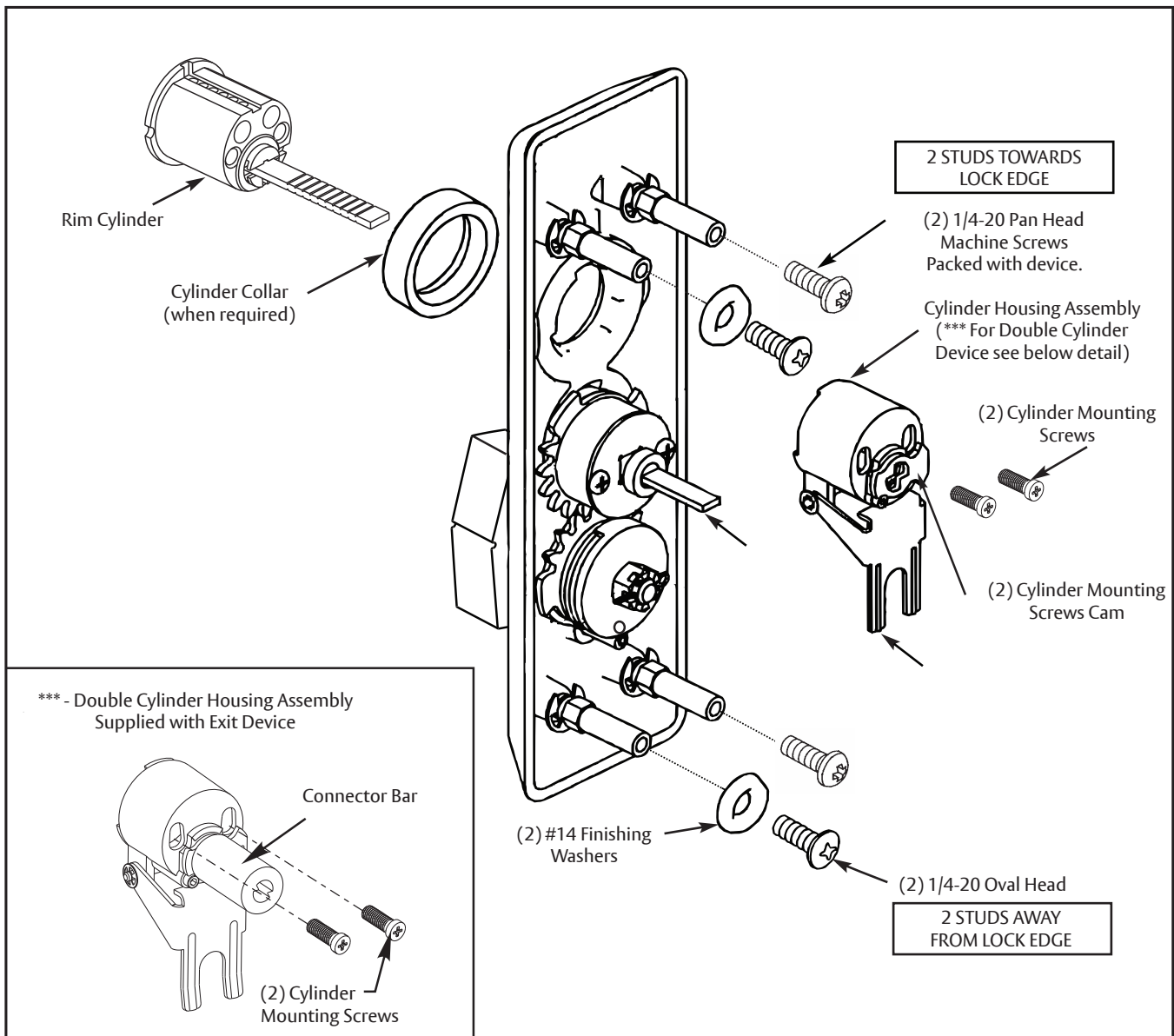

Installation Instructions

1. Assemble trim. See previous page for components and instructions.
2. After marking door inside face for device location (Device Instructions), transfer Vertical Reference Centerline from inside to outside door face. Follow steps 2a and 2b below.

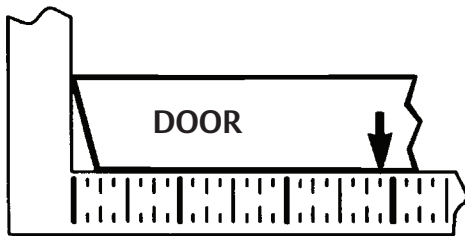

2a. MEASURE INSIDE LINE LOCATION.

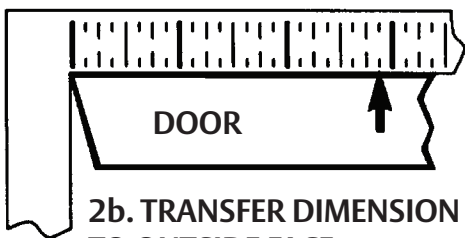

2b. TRANSFER DIMENSION TO OUTSIDE FACE

3. Transfer "Horizontal Reference Centerline" from inside to outside door face.

4. Align trim template and tape to outside door face.

CAUTION: Office copiers and facsimile machines may change the size of a drawing and make the template inaccurate to use as a door marker. If this is not the original template packed with the trim, use only the dimensions written on the template to locate the holes on the door (do not use the template as a door marker).

5. Spot holes and prepare door for trim.

6. Mount trim to door thru holes "B". Fasten, finger tight only, with 2 screws and washers seating on door, as shown in Figure 1.

7. Cut trim tailpiece, as shown in Figure 2.

8. Seat device so that trim tailpiece penetrates cam slot, as shown in Figure 1. Continue as shown in device instructions.

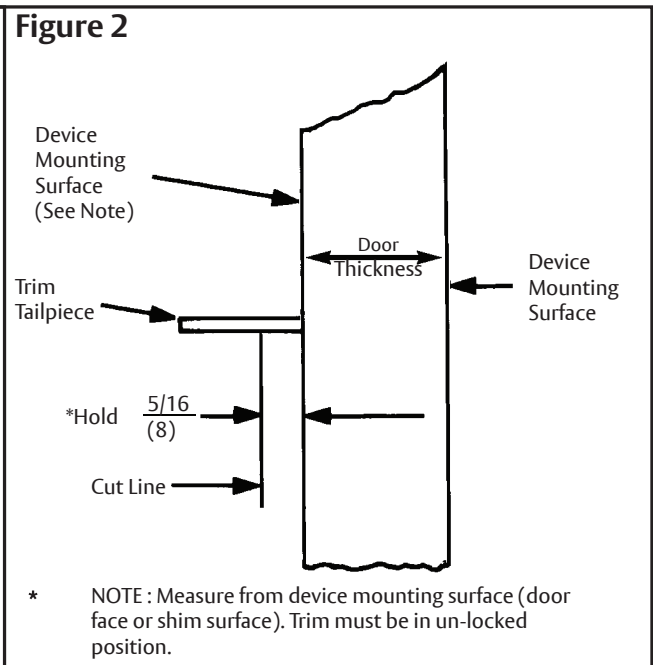
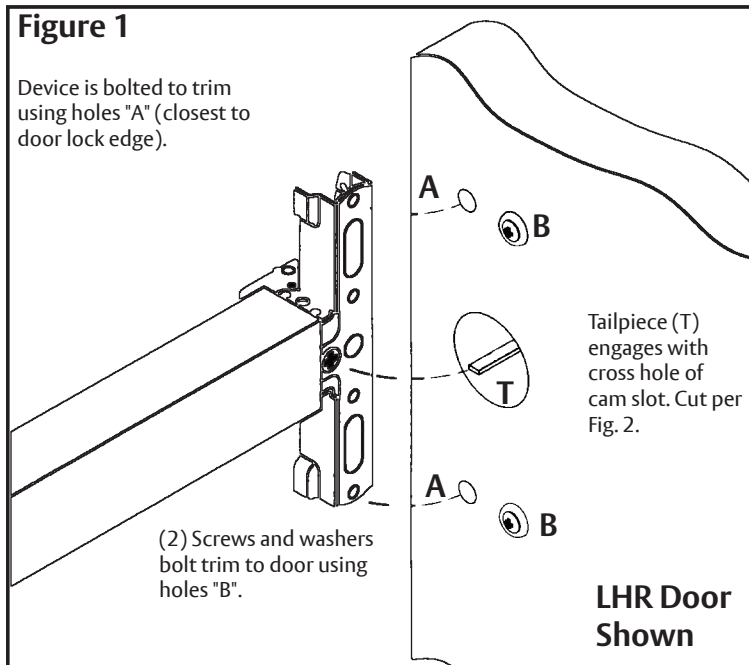

Outside Door Face

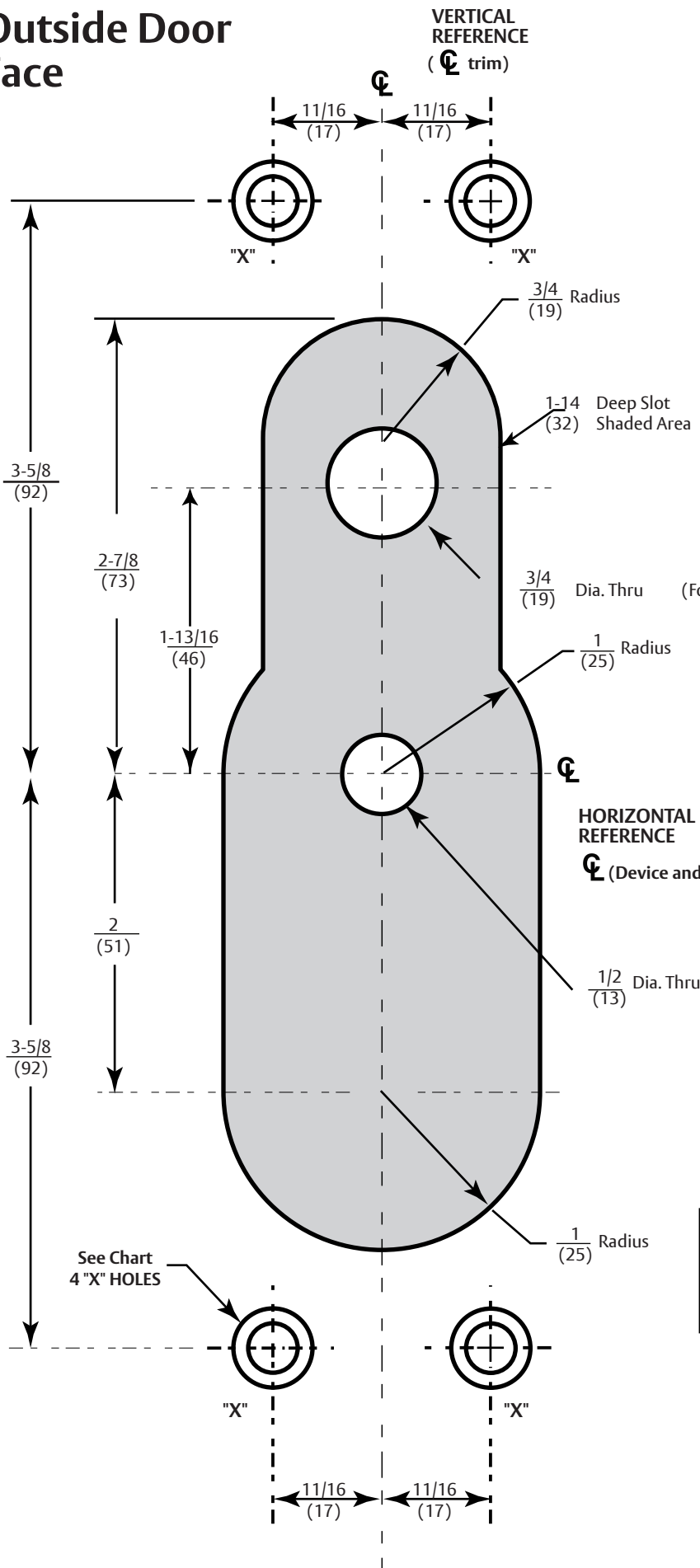

TRIM TEMPLATE

HOLES MARKED "X" (4 Places)	
METAL DOORS:	
Inside Face	5/16" (8) Dia.
Outside Face	1/2" (13) Dia.
WOOD DOORS:	
	1/2" (13) Dia. Thru

Dimensions given in inches (mm).

(For Double Cylinder Application Only)

CAUTION: Office copiers, printers and facsimile machines may change the size of a drawing and make the template inaccurate to use as a door marker.

