

# 6100 & 6150 Series

**ASSA ABLOY**

## Double Cylinder Latchhead Assembly Exit Device

### Installation Instructions

**For use with Rim 6100 and SquareBolt® 6150 Series Double Cylinder Exit Device and 626F Keyed Trim.**

1. Follow 626F trim installation instructions from the Rim Exit Device Installation Manual and Trim Kit Instructions.
2. Once the trim assembly is complete, continue with Double Cylinder Installation Instructions on page 2.

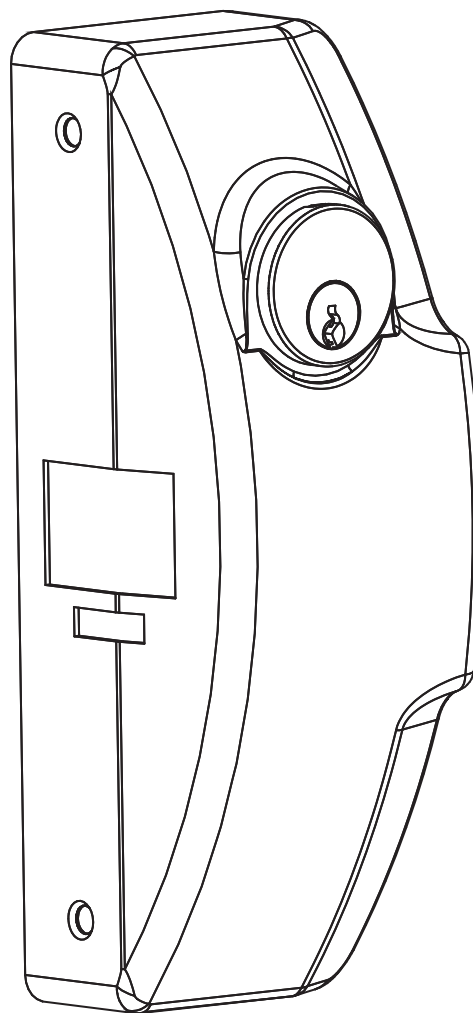
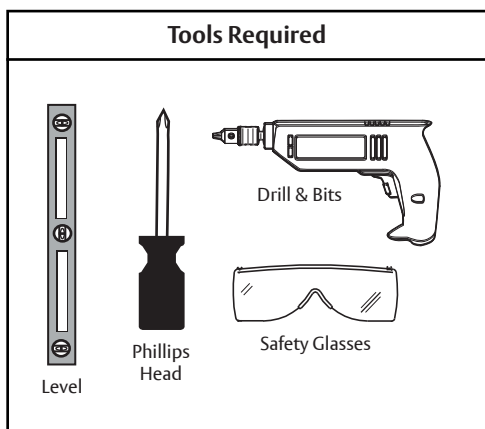

#### **⚠ WARNING**

This product can expose you to lead which is known to the state of California to cause cancer and birth defects or other reproductive harm. For more information go to [www.P65warnings.ca.gov](http://www.P65warnings.ca.gov).

#### **⚠ WARNING**

Attention Installer: Any retrofit or other field modification to a fire rated opening can potentially impact the fire rating of the opening, and ASSA ABLOY makes no representations or warranties concerning what such impact may be in any specific situation. When retrofitting any portion of an existing fire-rated opening, or specifying and installing a new fire-rated opening, please consult with a code specialist or local code official (Authority Having Jurisdiction) to ensure compliance with all applicable codes and ratings.

80-9460-6007-000 01/24

1-855-557-5078 • [www.assaabloy.com](http://www.assaabloy.com)

Copyright © 2015, 2024, ASSA ABLOY Access and Egress Hardware Group, Inc. All rights reserved. Reproduction in whole or in part without the express written permission of ASSA ABLOY Access and Egress Hardware Group, Inc. is prohibited.

Experience a safer  
and more open world

## Assemble Locking Device Cover

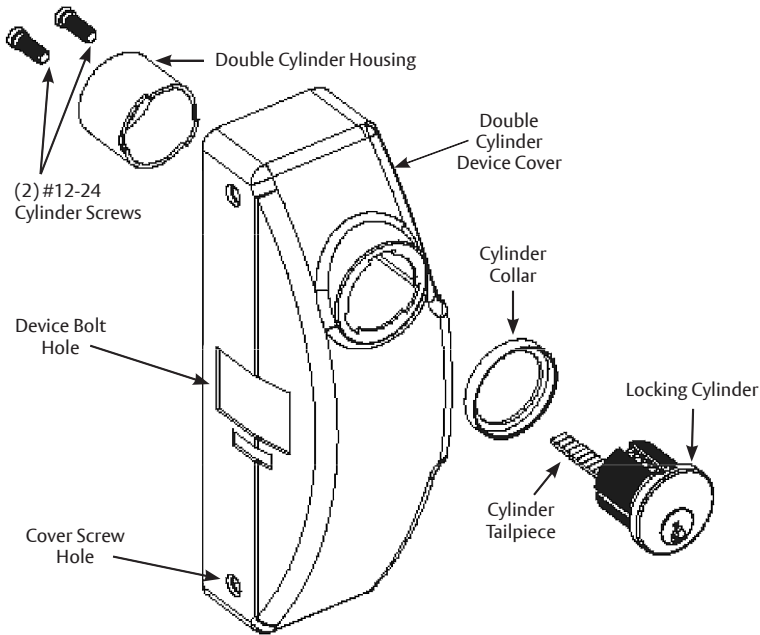

## Attach Cover Screws

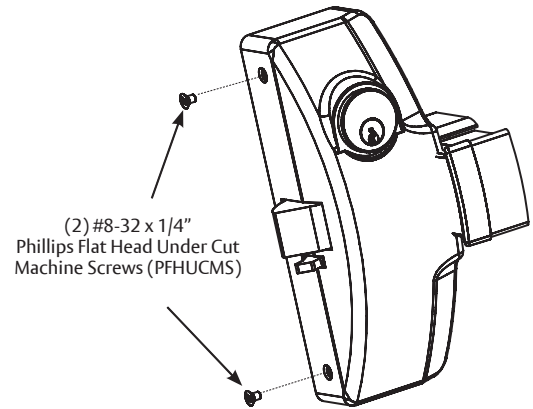

3. To install the Double Cylinder:
  - a. Identify parts and assemble the device cover as shown. Pass the lock cylinder through the cylinder collar, device cover and cylinder housing as shown. Fasten the cylinder housing to the cylinder with two (2) #12-24 cylinder screws. The keyway position should be vertical with the logo at the top side of the cylinder as shown.
  - b. Insert the cylinder tail piece into the cylinder collar of the double cylinder housing assembly (tailpiece length to be adjusted as needed for non-interference with opposing trim cylinder tailpiece).
4. Attach the device cover by tightening two (2) #8-32 x 1/4" screws on side of cover.
5. Check for proper functional operation of trim, key (cylinder) and exit device touchbar.

## Exit Device Fully Assembled

