

623F

Exit Device Trim

Installation Instructions

ACCENTRA

ASSA ABLOY

For use with all ASSA ABLOY
ACCENTRA™ 7000, 2100, 1800
and 1500 Series Exit Devices
(Wood and Metal Doors)

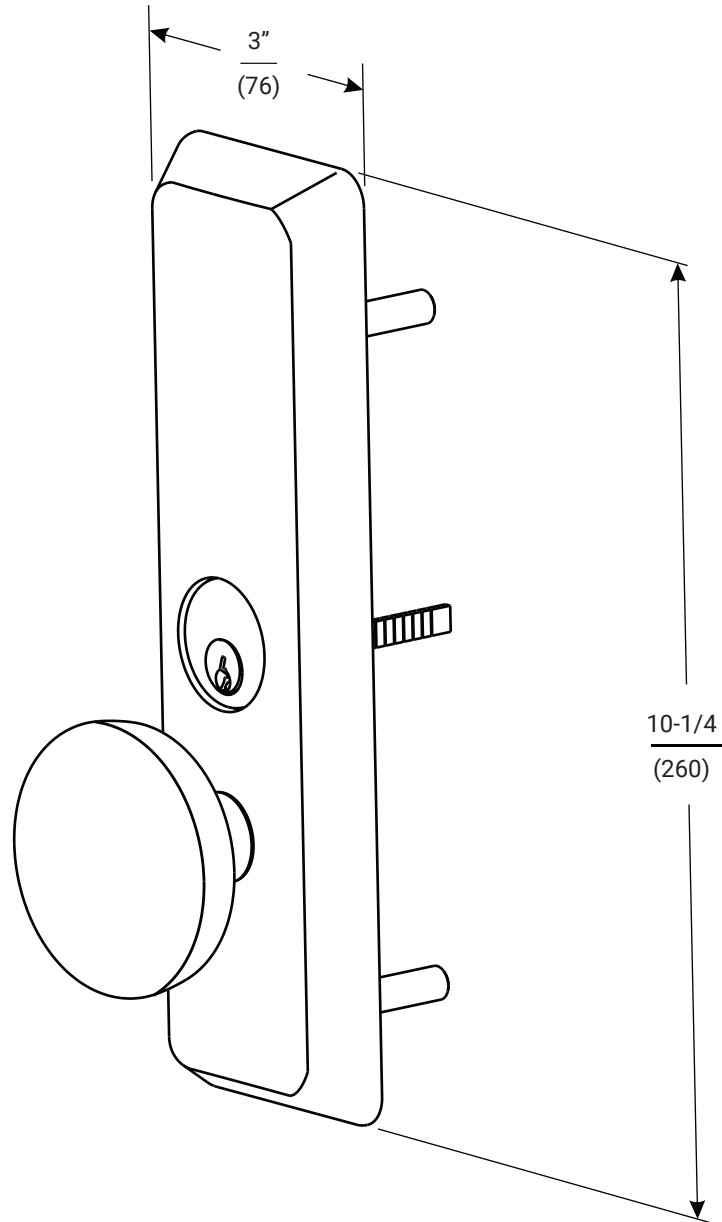

WARNING

This product can expose you to lead which is known to the state of California to cause cancer and birth defects or other reproductive harm. For more information go to www.P65warnings.ca.gov.

WARNING

Attention Installer: Any retrofit or other field modification to a fire rated opening can potentially impact the fire rating of the opening, and ASSA ABLOY makes no representations or warranties concerning what such impact may be in any specific situation. When retrofitting any portion of an existing fire-rated opening, or specifying and installing a new fire-rated opening, please consult with a code specialist or local code official (Authority Having Jurisdiction) to ensure compliance with all applicable codes and ratings.

1-855-557-5078 Ext. 2 • www.accentra-assaabloy.com

80-8470-0623-000 04/24

Trim Assembly Instructions

1. Check cylinder components.

NOTE: Cylinders longer than 1-1/8" (29) will require collars. Refer to cylinder collar chart.

2. Assemble cylinder.

Insert cylinder housing prongs into matching notches of escutcheon. Pass cylinder tailpiece thru cylinder collar (when required) and hole in cylinder housing. Fasten cylinder using (2) mounting screws.

DO NOT OVER TIGHTEN SCREWS.

Cylinder Collar Chart	
Cylinder Length	Collar
1-1/8" (29)	None
1-1/4" (32)	**
1-1/2" (38)	**

** Specify finish

623F Nightlatch Trim

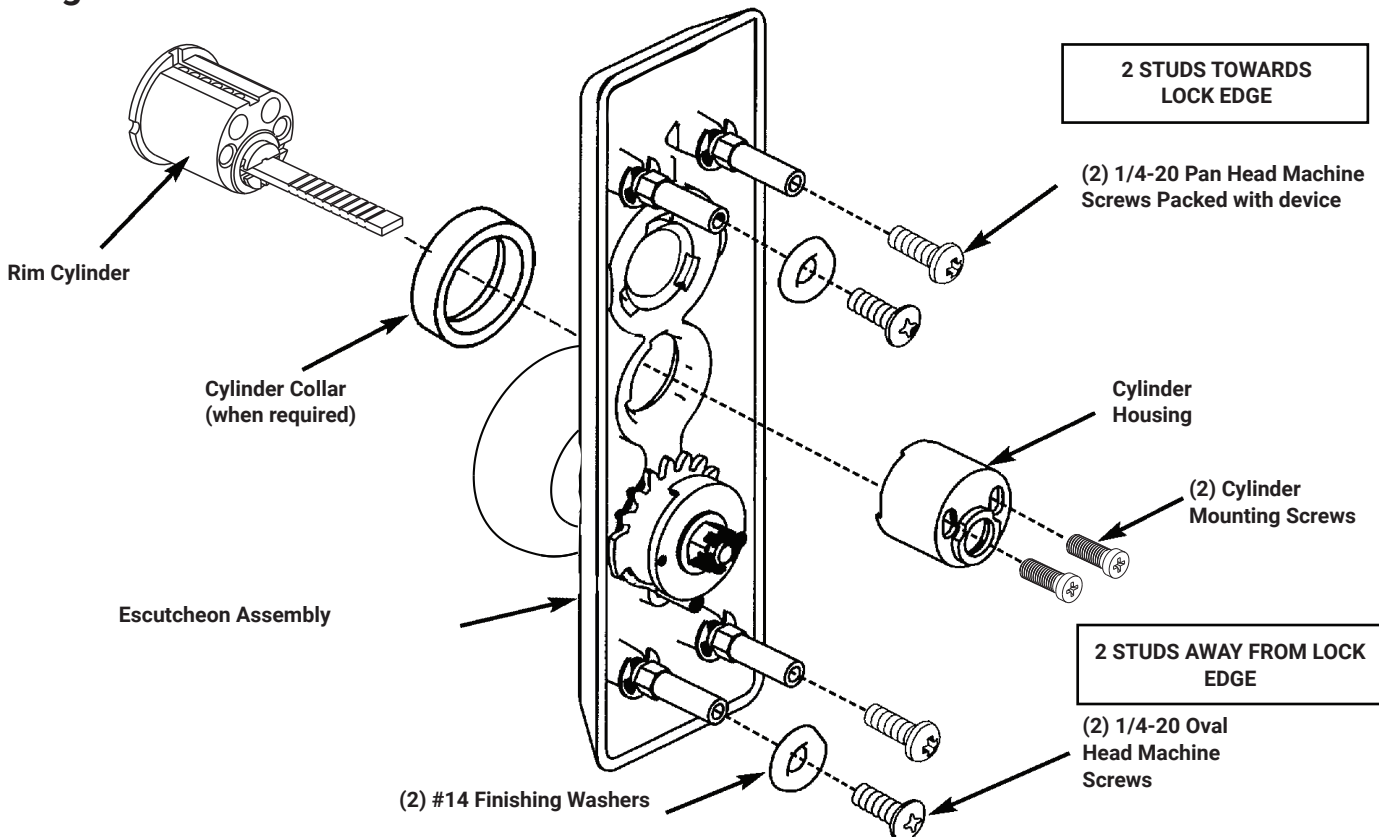

80-8470-0623-000 04/24

Experience a safer
and more open world

1-855-557-5078 Ext. 2 • www.accentra-assaabloy.com

Copyright © 2013, 2024, ASSA ABLOY ACCENTRA™ Access and Egress Hardware Group, Inc. All rights reserved. Reproduction in whole or in part without the express written permission of ASSA ABLOY Access and Egress Hardware Group, Inc. is prohibited.

Installation Instructions

1. Check box for contents. See previous page for components
2. After marking door inside face for device location (Device Instructions), transfer Vertical Reference Centerline from inside to outside door face. Follow steps 2a. and 2b. below.
3. Transfer Horizontal Reference Centerline from inside to outside door face.
4. Align trim template and tape to outside door face.
5. Spot holes and prepare door for trim
6. Mount trim to door thru holes "B". Fasten finger tight only with (2) screws and washers seating on door as shown in Fig. 1
7. Cut trim tailpiece as shown in Figure 2.
8. Seat device so that the trim tailpiece penetrates the cam slot as shown in Figure 1. Continue as shown in the device instructions.

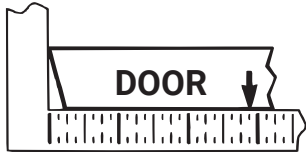

2a. MEASURE INSIDE LINE LOCATION.

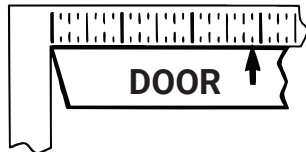

2b. TRANSFER DIMENSION TO OUTSIDE FACE.

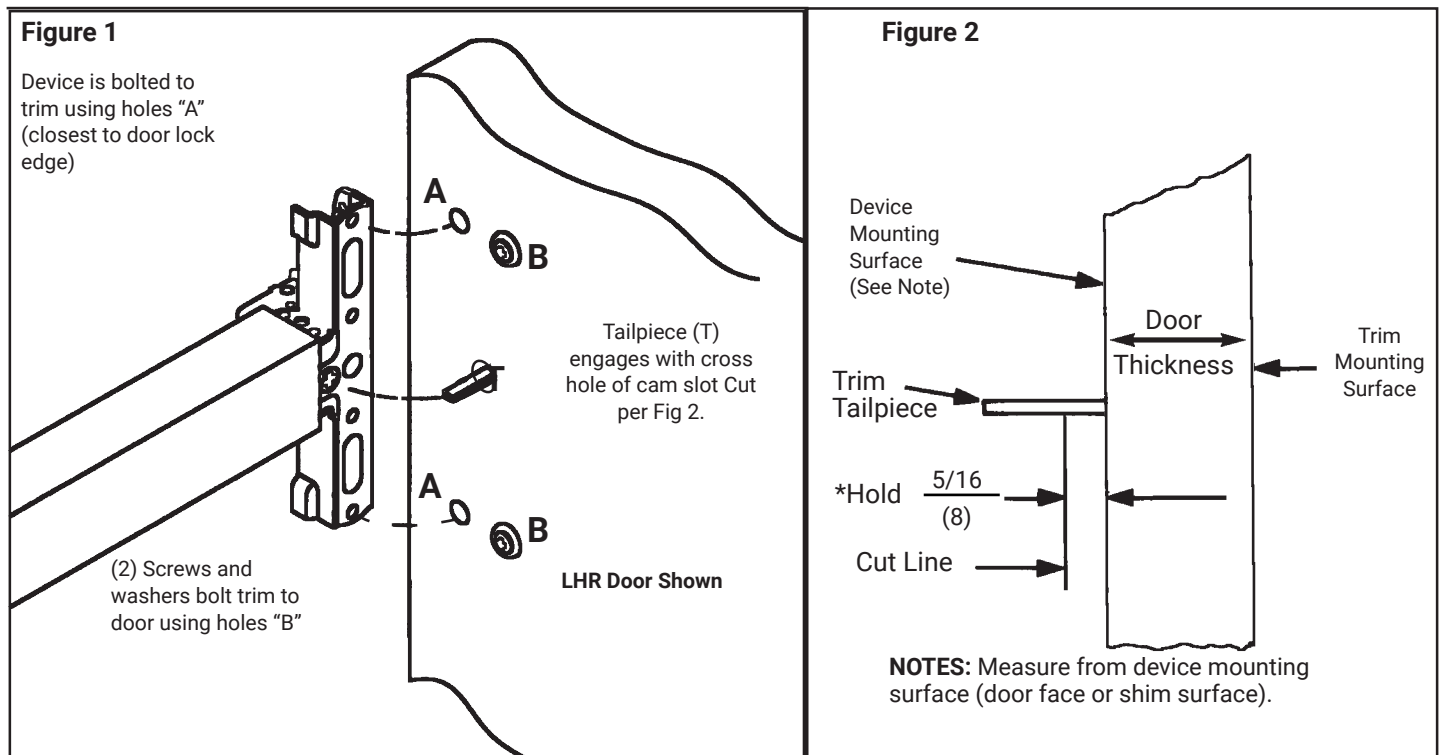

Trim Template

HOLES MARKED "X" (4 Places)	
METAL DOORS:	
Inside Face	5/16" (8) Dia.
Outside Face	1/2" (13) Dia.
WOOD DOORS:	1/2" (13) Dia. Thru

Dimensions given in $\frac{\text{Inches}}{\text{(mm)}}$

TRIM	HOLES
623F	A, B, C, X

CAUTION:
Office copiers, printers and facsimile machines may change the size of a drawing and make the template inaccurate to use as a door marker.

