

# 7250 SquareBolt® Exit Device

## (Single Doors or Pairs with M300 Mullion)

# ASSA ABLOY

Patent 5,605,362

### Installation Instructions

**Note:** These installation instructions cover standard product only. To install options, such as shim kits, refer to the instructions packed with optional component.

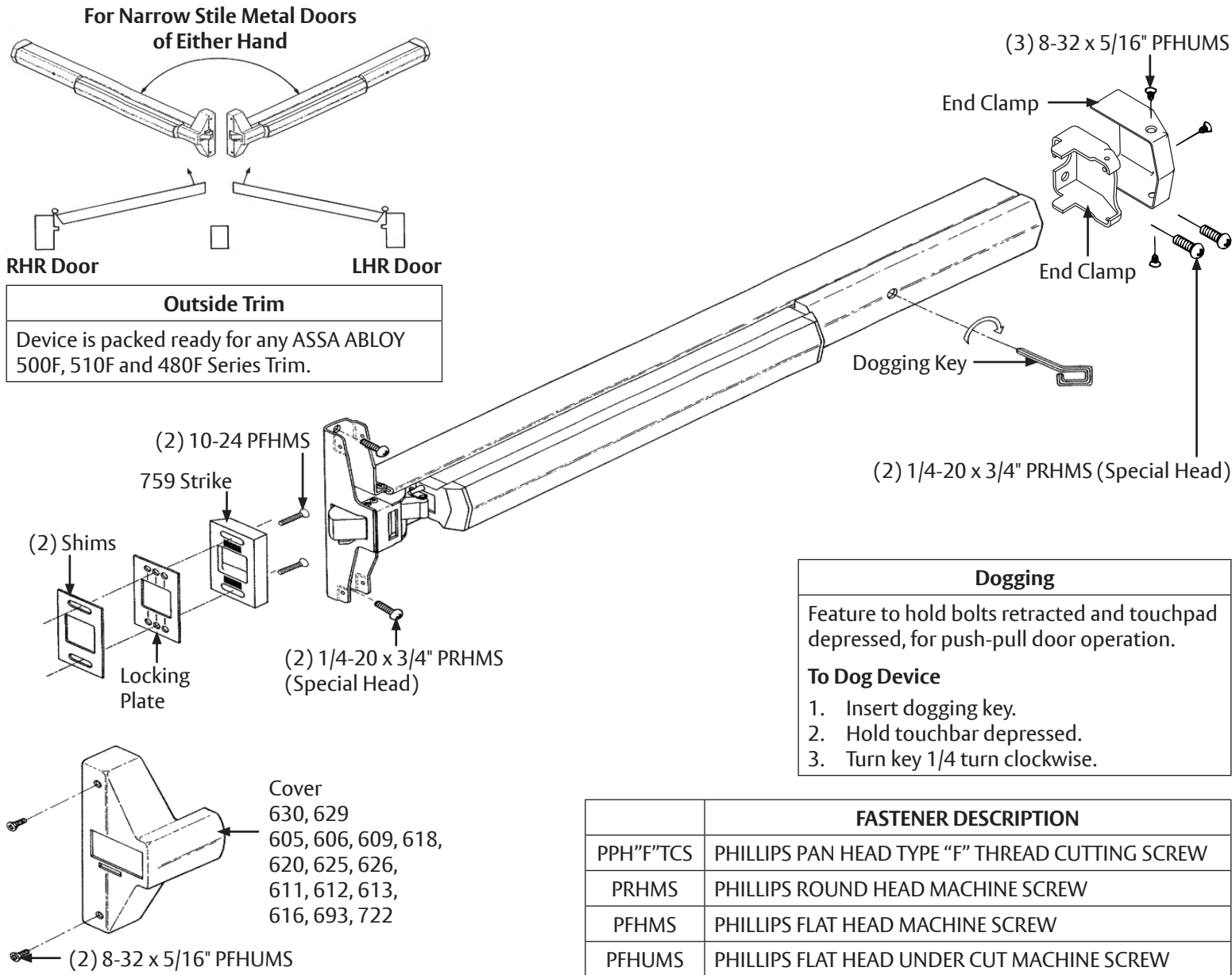

### ⚠ WARNING

This product can expose you to lead which is known to the state of California to cause cancer and birth defects or other reproductive harm. For more information go to [www.P65warnings.ca.gov](http://www.P65warnings.ca.gov).

### ⚠ WARNING

Attention Installer: Any retrofit or other field modification to a fire rated opening can potentially impact the fire rating of the opening, and ASSA ABLOY makes no representations or warranties concerning what such impact may be in any specific situation. When retrofitting any portion of an existing fire-rated opening, or specifying and installing a new fire-rated opening, please consult with a code specialist or local code official (Authority Having Jurisdiction) to ensure compliance with all applicable codes and ratings.

80-9472-0050-000 11/23

1-855-557-5078 • [www.assaabloy.com](http://www.assaabloy.com)

Experience a safer  
and more open world

### Shim Kit Option

Model Number: 723N Black Finish

Kit consists of Latch Head Shim (Device Cover seats on shim) and End Clamp Shim (End Cap seats on shim).

Each shim is 1/8" (3.2) thick.

More than two Shim Kits require longer device mounting screws (not included).

### Sex Nut Option

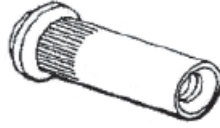

Specify Finish

Recommended for unreinforced metal doors.

Device	Quantity	Size	Part Number
No Trim	4	1/4-20	66-0001-1745
With Trim	2		

### Maintenance

1. Periodically remove covers and coat mechanisms with a silicone base lubricant. This is particularly required in corrosive environments for proper product function.
2. Check mounting fasteners periodically. Retighten if found loose. Apply screw locking compound (available at automotive part stores) or change part fasteners if screws continue to back out.

### Check Before Starting

#### Unreinforced Doors or Frames

Doors and Frames with walls having a structural thickness (metal skin plus reinforcement or solid hardwood) to engage less than (3) full screw threads are considered unreinforced.

Unreinforced Doors:  
Use SNB (sex nuts and bolts).

Unreinforced Frames:  
Use Blind Rivet Nuts.

Recommended fasteners for unreinforced openings are not necessarily supplied by ASSA ABLOY Locks and Hardware.

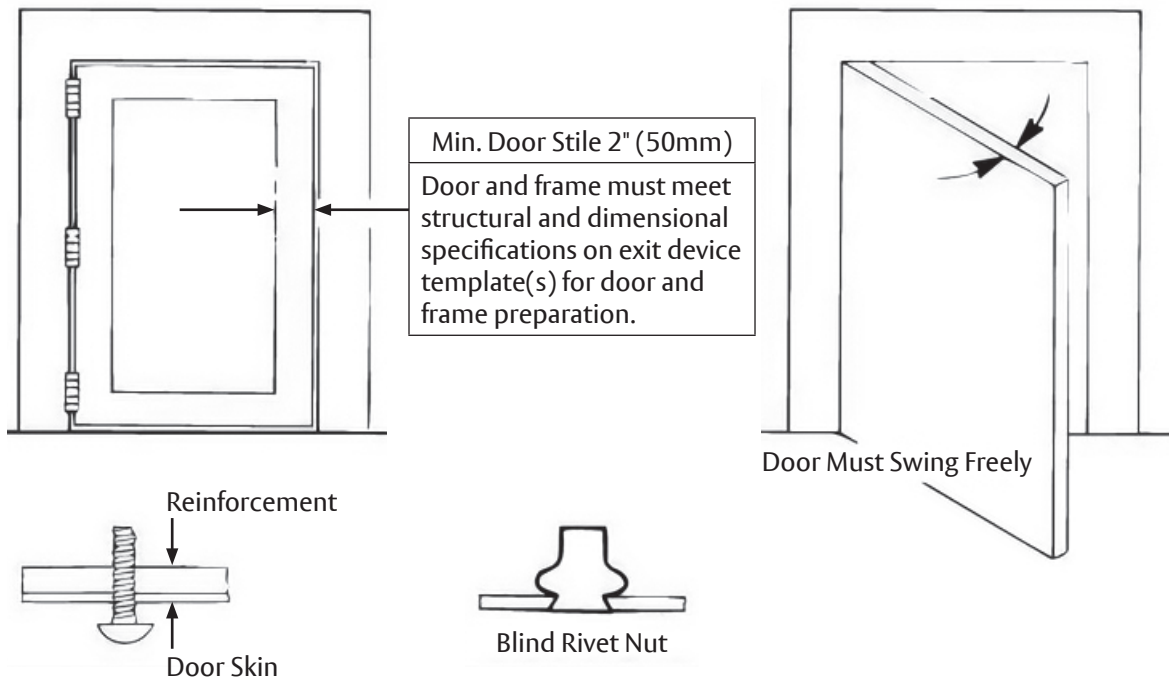

# 7250 SquareBolt® Exit Device

## (Single Doors or Pairs with M300 Mullion)

### Installation Instructions

## 1. Mark Door

Locate and Mark Horizontal and Vertical Reference Centerlines as shown.

**Note:** For other openings see step 2, Item A3.

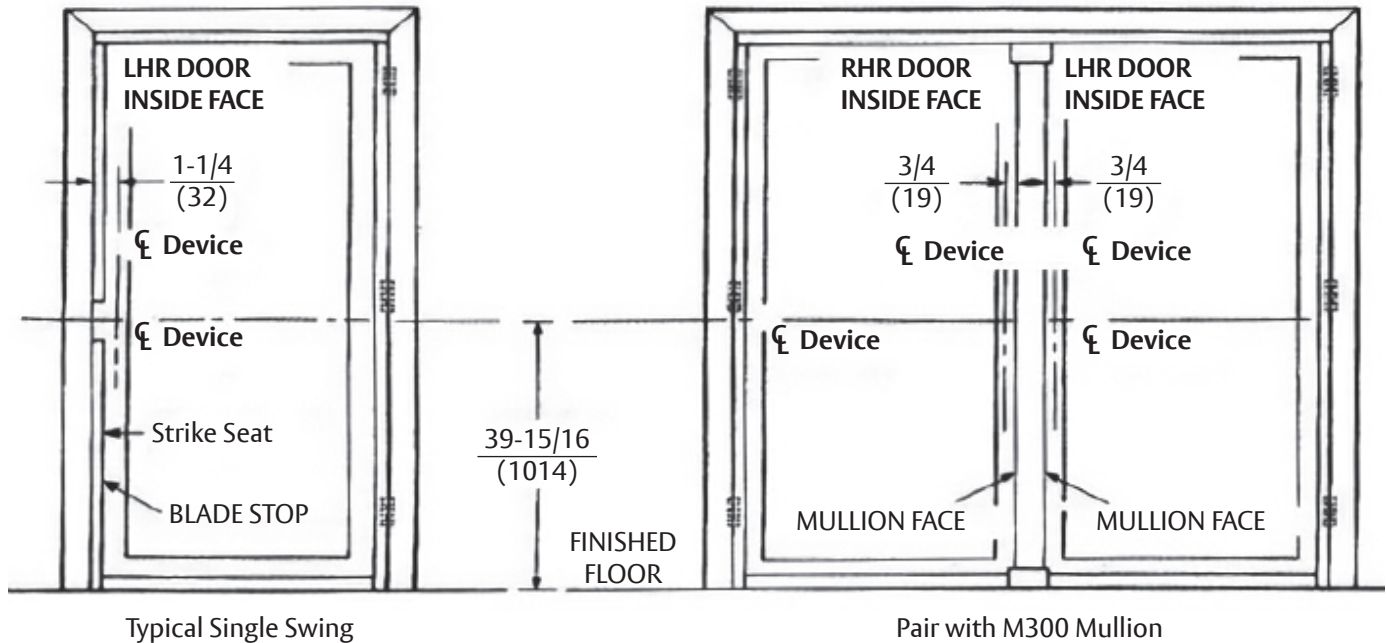

## 2. Prepare Door & Frame

1. Determine opening requirements.
  - a. Aluminum Single Openings: Stop must be notched to clear strike. Cutout is 3-1/8" (79) long, centered on Device centerline.
  - b. Pairs with M300 Mullions\*\*\*: Cut off and discard strike portion of Installation Template.
  - c. Other Openings: Door stile should exceed 2" (51) by height of frame stop or 1/2 the width of the mullion.
2. Seat template on door and jamb face (if pertinent).
3. Align template with horizontal and vertical device centerline on door. Tape template in place.
4. Locate and tape Trim template on door. (See instructions packed with trim.)
5. Spot and prepare holes.
  - Device:** (2) 1/4-20 Machine Screws\*, or (2) 3/8" (9.5) Dia Sex Nuts and Bolts.
  - Strike\*\*:** (2) 10-24 Machine Screws.

**Note:** (\*)Reinforced doors only. (\*\*)Plus template cutouts, if not factory prepared. (\*\*\*)Strike machined into the mullion. Position device carefully.

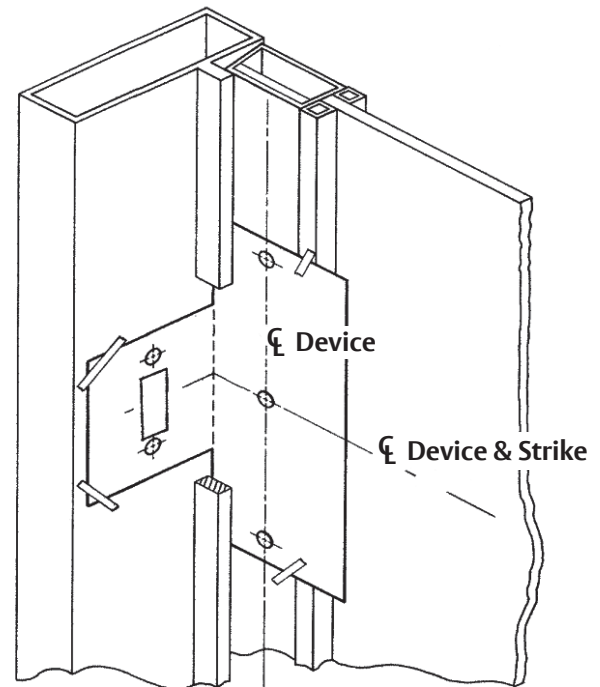

### 3. Size Device

Device must be field cut to size unless standard opening and device are 36" (0.91m) or 48" (1.22m).

LHR DOOR  
(Door Open)  
INSIDE FACE

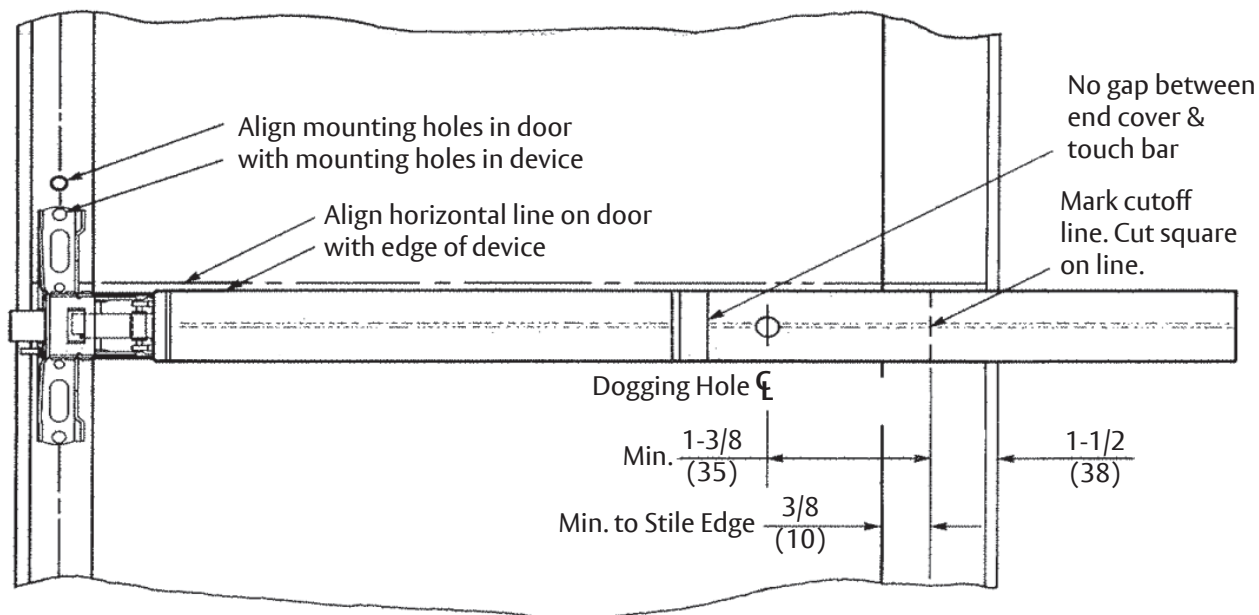

### 4. Clear Raised Door Molding

Device must seat flush on door surface or on shims that keep it parallel to door face.

(1) Shim Kit #723N required for each 1/8" (3mm) of device lift needed. Longer device mounting screws needed when more than (2) shim kits are used. See Shim Kits Option on page 2.

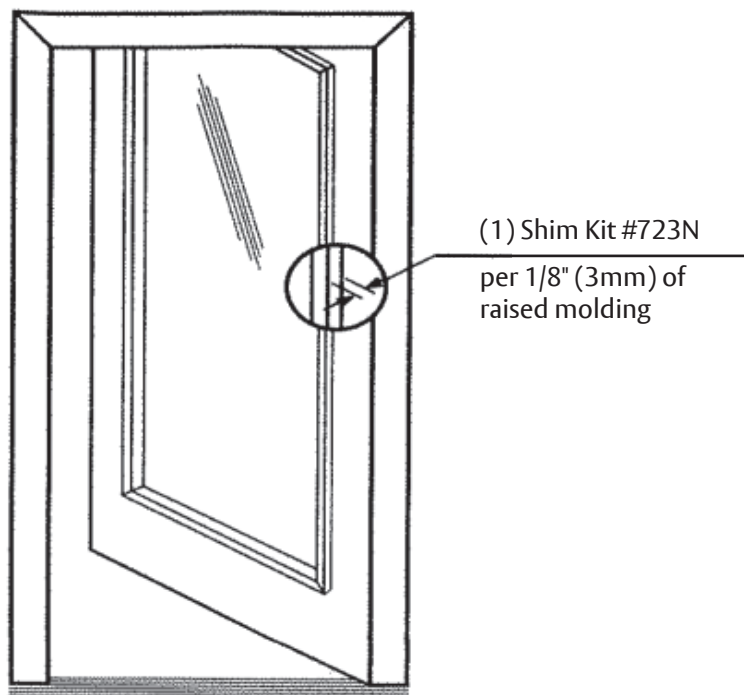

# 7250 SquareBolt® Exit Device (Single Doors or Pairs with M300 Mullion)

**ASSA ABLOY**

## Installation Instructions

### 5. Install Device

1. A. Mount trim (follow instructions packed with trim).
2. Seat bar in place (projecting C-Cam boss must penetrate into door hole). Fasten device head (2 PRHMS or SNB).door hole).  
Fasten device head (2 PRHMS or SNB).
3. Set bar level. Locate end clamp holes.
4. Prepare end clamp mounting holes. Mount end clamp.
5. Check bolt retraction.
  - a. Depress touchbar (bolts must retract). Release touchbar (bolts must extend).
  - b. Actuate trim (bolts must retract). Release trim actuator (bolts must extend).
  - c. Depress touchbar, turn dogging key clockwise (bar must remain depressed, bolts must remain retracted). Turn dogging key counterclockwise (bar and bolts must return to extended position).

**NOTE:** When resulting operation is faulty, check first for visible binding or interference. If there is no apparent reason for the fault, remove item from the door and recheck its operation before assuming that it is defective.

6. Tighten all mounting screws.

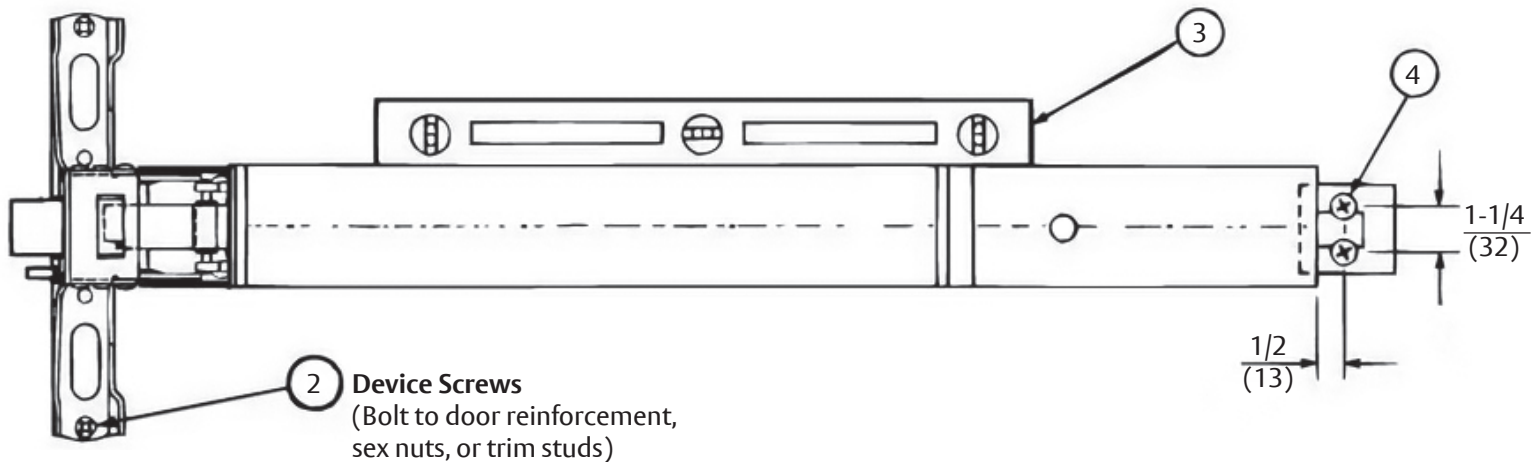

80-9472-0050-000 11/23

1-855-557-5078 • [www.assaabloy.com](http://www.assaabloy.com)

Copyright © 2020, 2023, ASSA ABLOY Access and Egress Hardware Group, Inc. All rights reserved. Reproduction in whole or in part without the express written permission of ASSA ABLOY Access and Egress Hardware Group, Inc. is prohibited.

Experience a safer  
and more open world

### 6. Install Strike

1. Position strike projection (strike + locking plate + shims, if needed). See Detail A.
2. Position strike depth. See Detail B.
3. Fasten strike securely (2 PFHMS).
4. Check bolt engagement.
  - a. Bolt should retract to clear the strike, when actuated by bar, trim, or dogging action. Bolt should consistently reengage the strike, when actuators are released and the door shuts.
  - b. Door should remain latched and not rattle when pushed, pulled, or shaken in/out.

Detail A

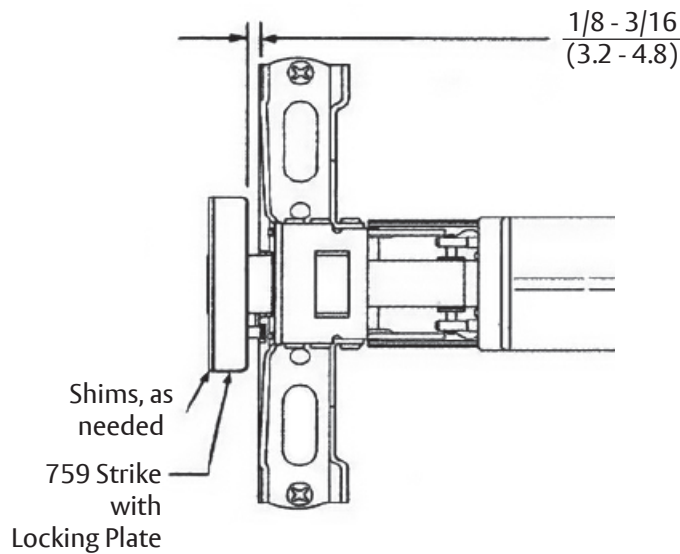

Detail B

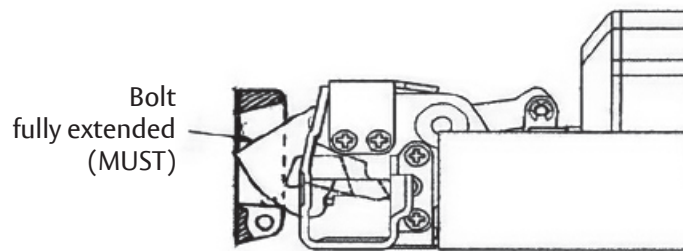

Use (2) 8-32 x 5/16" PFH MS for Cover and (3) for End Cap

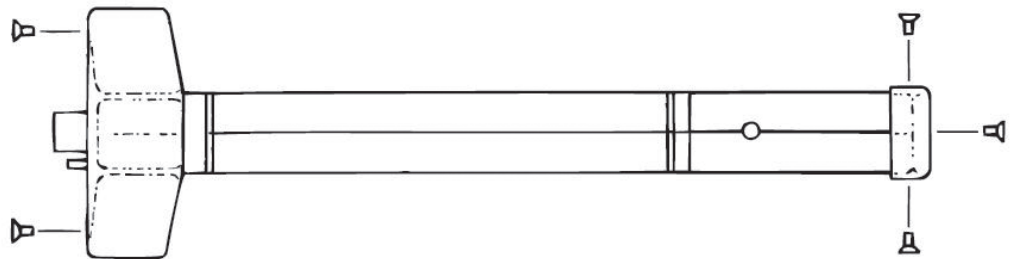

# 7250 SquareBolt® Exit Device

## (Single Doors or Pairs with M300 Mullion)

### Installation Instructions

#### 7250 Series Rim Exit Device Template

#### Frame Tube or Formed Stop Face

(Strike Seat)

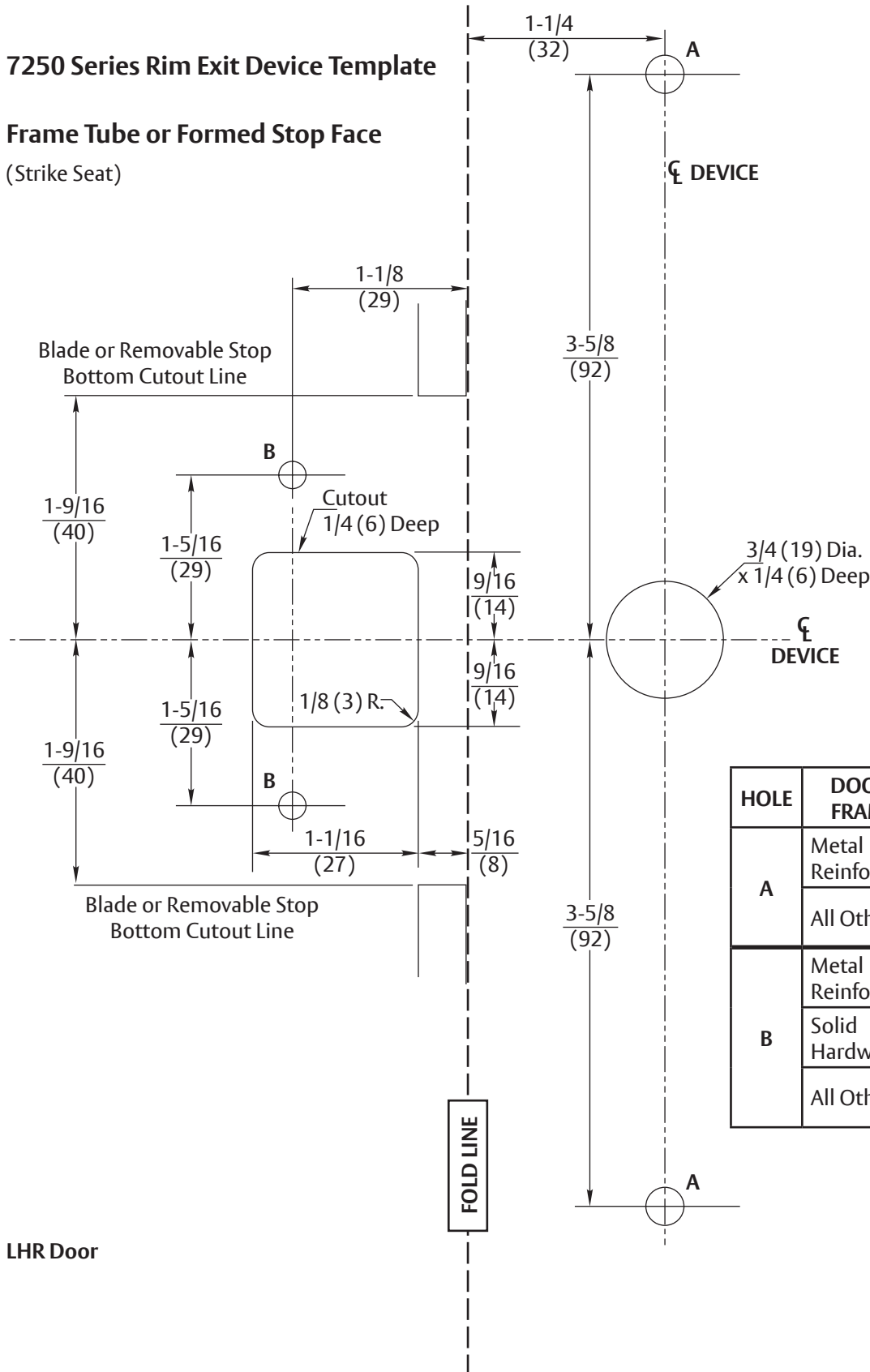

#### Door Inside Face Surface

(Device Seat)

#### Notes:

1. Not for 7250M(F) Series.
2. For pairs with M300 Mullion, cut off and discard frame portion. (See Installation Instructions for template location).
3. Unreinforced Frames require that 10-24 blind rivet nuts (by others) be used to bolt strike. Frames are considered not reinforced when strike mounting screws cannot engage (3) full threads.
4. Dimensions are given in inches (mm).
5. **CAUTION:** Office copiers and facsimile machines may change the size of a drawing and make the template inaccurate to use as a door marker. If this is not the original template packed with the device, use only the dimensions written on the template to locate the holes on the door (do not use the template as a door marker).

HOLE	DOOR/ FRAME	FASTENER	PREPARATION
A	Metal Reinforced	1/4-20 PRHMS	Drill: #7 (.201" dia.) Tap: 1/4-20
	All Others	1/4-20 SNB	3/8" (9.5mm) dia. Thru door
B	Metal Reinforced	10-24 PFHMS	Drill: #26 (.147" dia.) Tap: 10-24
	Solid Hardwood	#10x1-1/4" PFHWS	Pilot Hole: 11/64" (4.40mm) dia.
	All Others	See Note 3	As required for blind nut used.

LHR Door

1-855-557-5078 • www.assaabloy.com

Copyright © 2020, 2023, ASSA ABLOY Access and Egress Hardware Group, Inc. All rights reserved. Reproduction in whole or in part without the express written permission of ASSA ABLOY Access and Egress Hardware Group, Inc. is prohibited.

