

# M200FWS

# ASSA ABLOY

## Mullions

### Installation Instructions

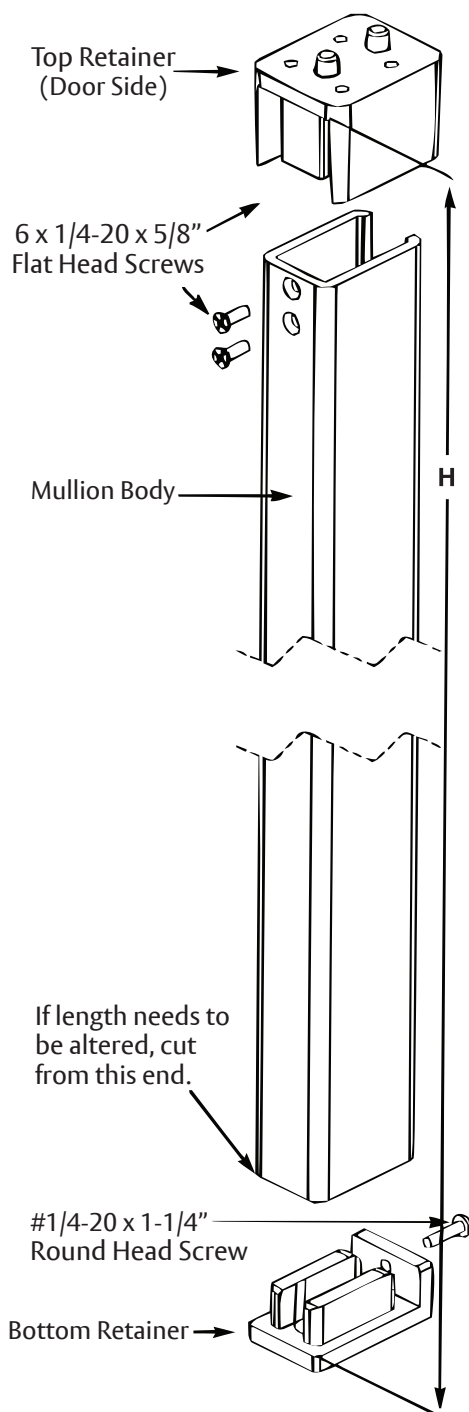

#### Tools Required:

- Measuring Tape
- Pencil
- Drill & Tap Sizes #7 drill and 1/4"-20 tap
- Concrete Drill 3/8" diameter
- 1/2" Drill
- Punch
- Hammer
- #3 Phillips Screw Driver

#### Attention: Before starting the installation make sure that

- You have the correct product
- Doors are properly installed and hinge screws are secure

#### 1. Attach the top retainer to the top jamb.

- a. Mark the centerline of the top retainer on the top jamb.
- b. Close the doors and keep door leaves tight to the stops.
- c. Fold the supplied template 80-7401-0206-000 along the creased line and locate it on the top jamb using the centerline marked. Attach it to the frame and doors with self adhesive strips supplied.
- d. Mark drill and tap holes required.
- e. Install the top retainer using (4) four 1/4-20 x 5/8" flat head screws.

#### 2. Locate the bottom retainer on the floor.

**Attention:** Do NOT attach the retainer to the floor at this point.

#### 3. Cut the mullion body to size.

- a. Measure the distance (H) between the inside surface of the top retainer and the top of the bottom retainer surface as shown.
- b. Cut off bottom of the mullion body to desired length (L) using the following formula  $L = H - 1/16"$  (1.6)

#### 4. Position the mullion body into the bottom and top retainers and locate it vertically. Mark the bottom retainer location on the floor (Bottom retainer still free to move). **Attention:** Make sure that the mullion surface is engaged with the doors and mullion is plumb to door face and frame.

#### 5. Install the bottom retainer.

- a. Remove the mullion body from the retainers and put it aside.
- b. Align bottom retainer with previous markings from Step 4.
- c. Use a punch and hammer to mark hole locations on floor.
- d. Drill (2) 3/8" (9.5) dia. holes in floor to a min. depth of 2-5/8" (66.7).
- e. Mount the bottom retainer to the floor with supplied (2) 3/8" fasteners.

#### WARNING

This product can expose you to lead which is known to the state of California to cause cancer and birth defects or other reproductive harm. For more information go to [www.P65warnings.ca.gov](http://www.P65warnings.ca.gov).

#### WARNING

Attention Installer: Any retrofit or other field modification to a fire rated opening can potentially impact the fire rating of the opening, and ASSA ABLOY makes no representations or warranties concerning what such impact may be in any specific situation. When retrofitting any portion of an existing fire-rated opening, or specifying and installing a new fire-rated opening, please consult with a code specialist or local code official (Authority Having Jurisdiction) to ensure compliance with all applicable codes and ratings.

80-7401-0203-000 12/23

1-855-557-5078 • [www.assaabloy.com](http://www.assaabloy.com)

Experience a safer  
and more open world

6. Install the mullion body.
  - a. Position the mullion body first into the bottom retainer, then the top retainer.
  - b. Drill and tap two 1/4-20 holes in the top retainer thru the countersunk holes in the mullion body.
  - c. Install two 1/4-20 x 5/8" flat head screws.
  - d. Drill and tap one 1/4-20 hole in the bottom end of the mullion body thru the hole in the bottom retainer.
  - e. Install one 1/4-20 x 1-1/4" round head screw.
7. Install exit devices according to manufacturer's instructions.
8. **Fire rated Rim and SquareBolt® Exit Devices:**  
After exit devices and strikes have been assembled, install Interlock Brackets with #10-24 x 3/4" screws as shown in illustration below.

## Interlock Installation

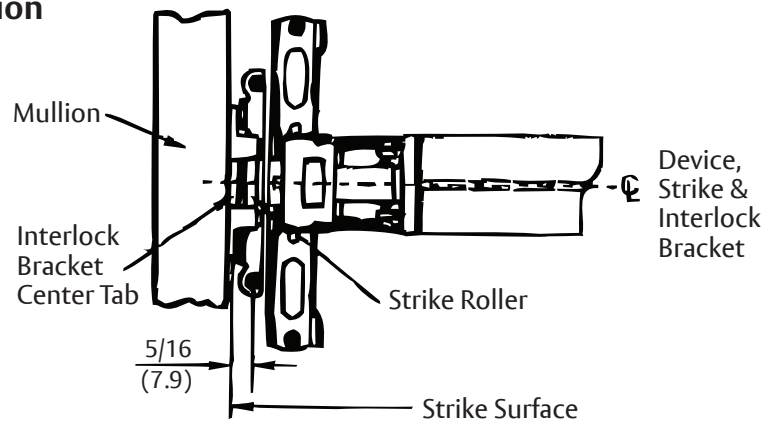
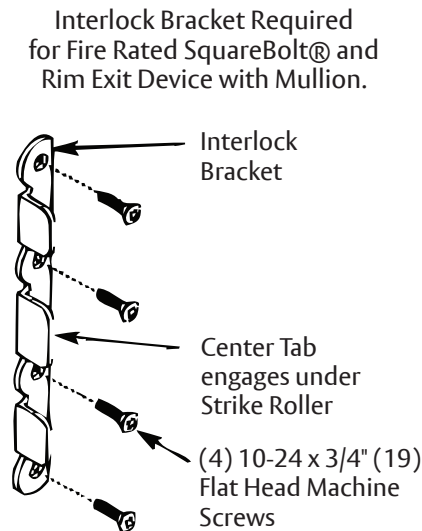

1. Position strike Interlock Bracket in place, as shown. Locate bracket holes.
2. Prepare Interlock Bracket mounting holes and mount with (4) 10-24 x 3/4" screws (and SNG's when applicable)