

**METAL JAMB PREPARATION**

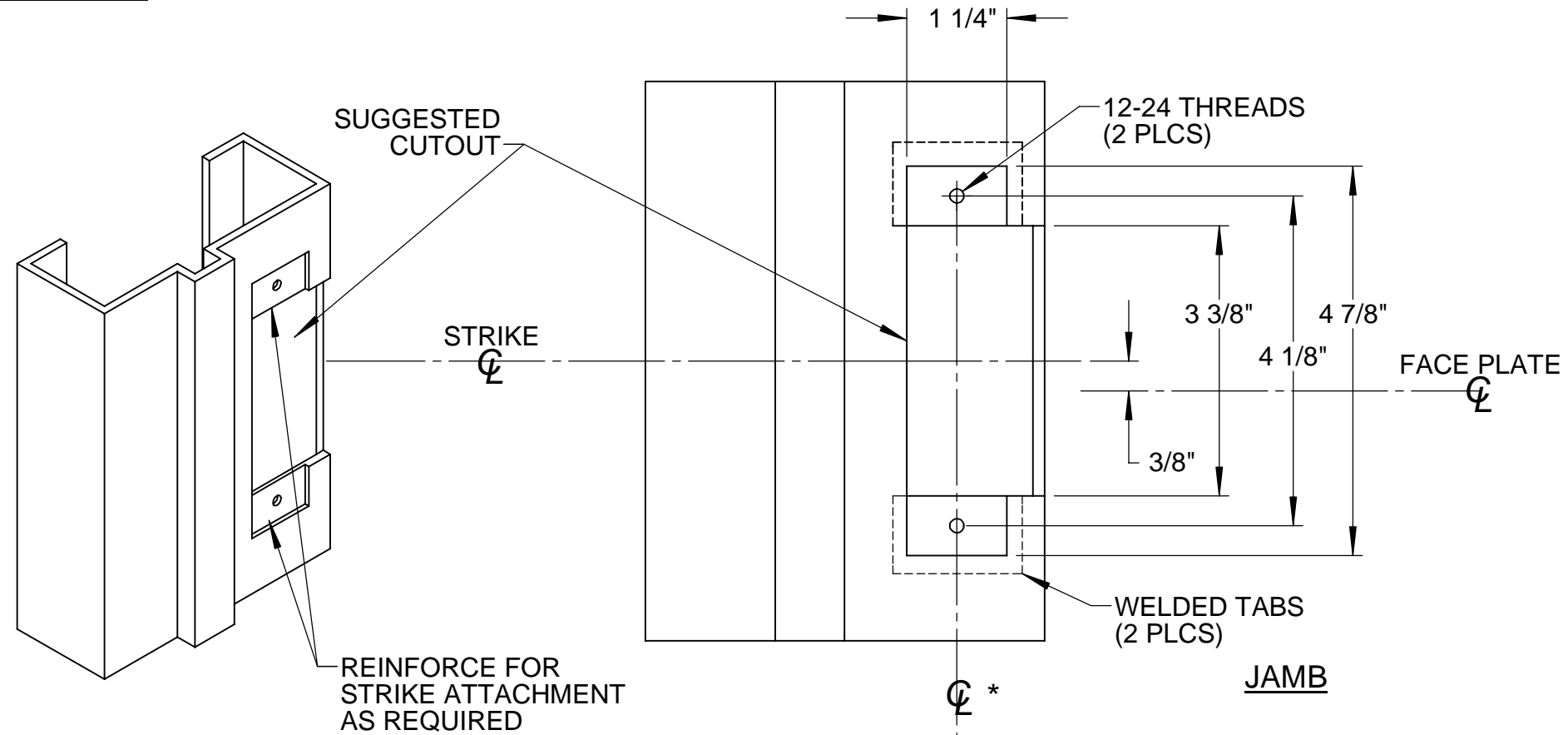

LHR SHOWN  
RHR OPPOSITE

1. STRIKE CUTOUT FOR FRAME FITS CURRENT ANSI A115.1 STANDARD.
2.  $\varnothing^*$  DENOTES A COMMON LATCH AND STRIKE CENTERLINE.
3. WHEN DOOR SILENCERS ARE USED ON DOOR FRAME, ADJUST STRIKE LOCATION TO ENSURE COMMON LATCH AND STRIKE CENTERLINE.

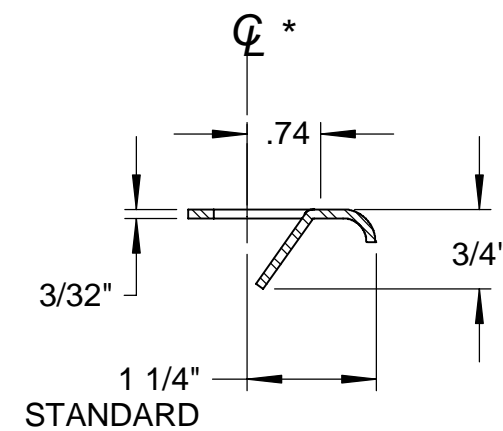
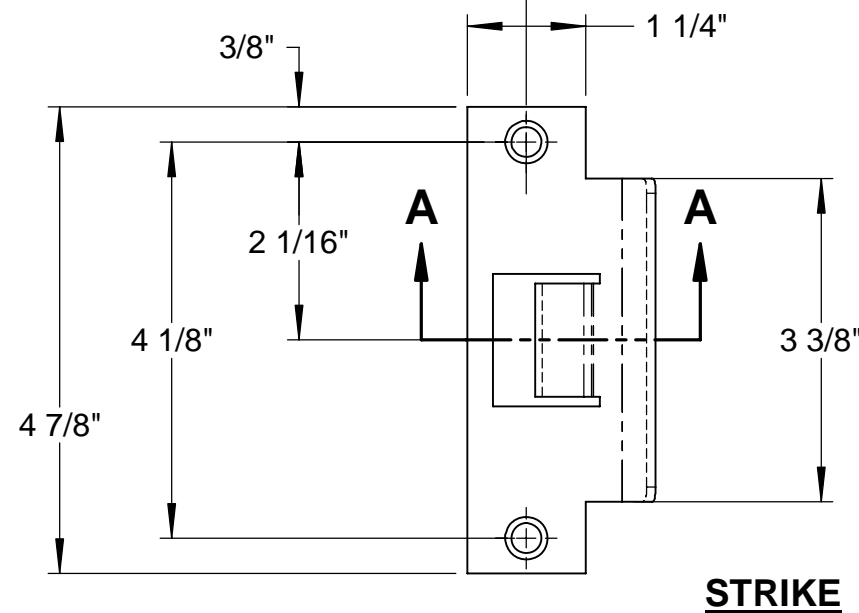

**SECTION A-A**