

- NOTE 1: FOR SELF-TAPPING SCREW MOUNTING: DRILL 1/8 DIA HOLE (10 PLCS). FOR SEX BOLT MOUNTING: REFER TO NOTE 2 FOR DRILL HOLE SIZE.
- NOTE 2: UNLESS OTHERWISE SPECIFIED, ALL 4 HOLES (●) ARE 3/8 DIA THRU HOLES.
- NOTE 3: WHEN BAR HEIGHT IS 36" OR MORE, DIVIDE BAR HEIGHT BY 2. OTHERWISE, USE 18" AS THE DIMENSION.
- NOTE: THESE DIMENSIONS AND TEMPLATES ASSUME A DOOR THICKNESS OF 1 3/4". FOR DOORS OF OTHER THICKNESS, CONSULT FACTORY.

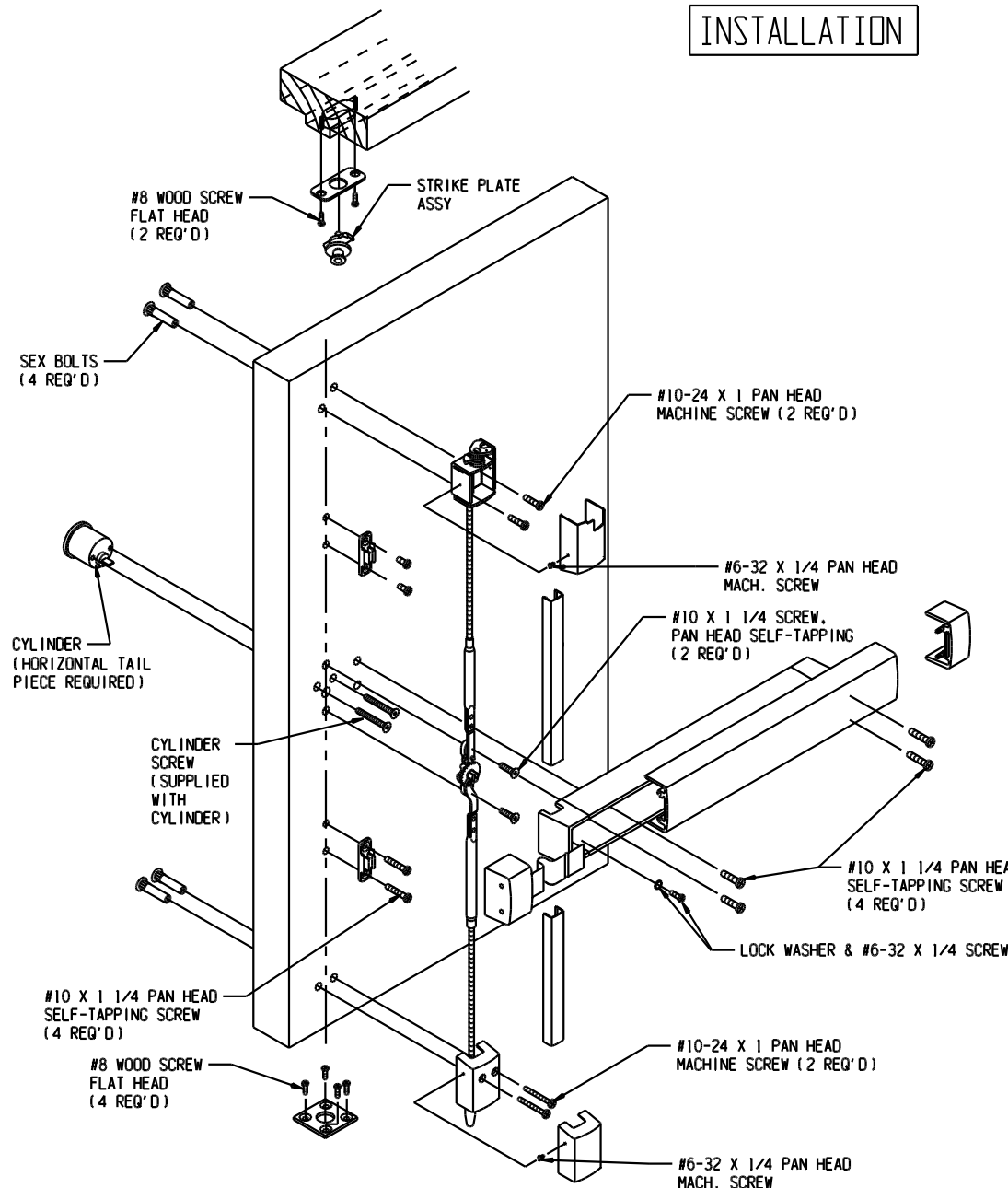

METRIC EQUIVALENTS									
INCHES	MM	INCHES	MM	INCHES	MM	INCHES	MM	INCHES	MM
3/32	2,36	25/64	10,16	13/16	20,62	1 13/32	35,56	26	660,40
1/8	3,17	7/16	11,11	7/8	22,22	1 1/2	38,10	30	762,00
3/16	4,75	29/64	11,56	29/32	22,86	1 23/32	43,64	32	812,80
7/32	5,53	1/2	12,70	1	25,40	2 3/64	52,07	36	914,40
15/64	6,10	5/8	15,86	1 3/16	30,14	2 13/64	55,88	38	965,20
1/4	6,35	11/16	17,45	1 1/4	31,75	3 19/32	91,44	42	1066,80
9/32	7,14	3/4	19,05	1 11/32	34,29	4 19/32	116,66	44	1117,60
3/8	9,52	51/64	20,32	1 3/8	34,93	18	457,20	48	1219,20

BACKSET	DOOR OPENING WIDTH			
	30"	36"	42"	48"
DIM A	24 1/4	30 1/4	36 1/4	42 1/4

CUT-OFF INSTRUCTIONS FOR NON-STANDARD DOORS

1. DRIVE OUT TWO ROLL PINS.
2. REMOVE MOUNTING CAP.
3. COLLAPSE BAR AND TAPE DOWN IN THE AREA OF CUT-OFF.
4. DETERMINE EXTRUSION LENGTH ("C" DIM). (NOTE: 3 19/32" MINIMUM DIMENSION FROM RIVET CENTERLINE TO NEW CUT-OFF LENGTH AS SHOWN).
5. MEASURE MOUNTING BAR (NOT PUSH BAR), AND MARK EXTRUSION LENGTH ON TAPE.
6. SAW OFF EXCESS LENGTH, REMOVE TAPE AND DEBURR.
7. LAY MOUNTING CAP OVER MOUNTING BAR (FIG "D"), AND USE AS A GUIDE TO DRILL TWO 1/8" DIA HOLES.
8. RE-INSTALL MOUNTING CAP INTO MOUNTING BAR AND DRIVE TWO ROLL PINS INTO HOLES.
9. SEE INSTALLATION INSTRUCTIONS.

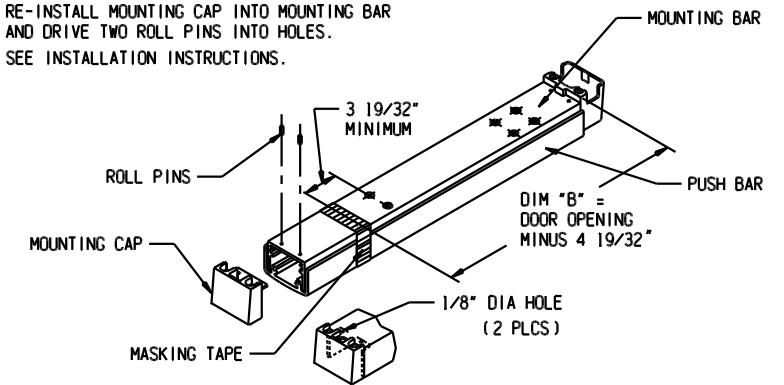

SEPARATING PUSH BAR AND MOUNTING BAR PROCEDURE

1. REMOVE BOTH END CAPS. THE RETAINER IS ATTACHED TO THE NOSE END CAP.
2. SLIDE PUSH BAR TOWARD HINGE SIDE OF DOOR.
3. CONTINUE TO SLIDE PUSH BAR PAST THE PIVOT PLATE THAT RIDES IN PUSH BAR TRACK.
4. SLIDE PUSH BAR IN OPPOSITE DIRECTION KEEPING PIVOT PLATE OUT OF TRACK UNTIL PUSH BAR IS FREE OF MOUNTING BAR.

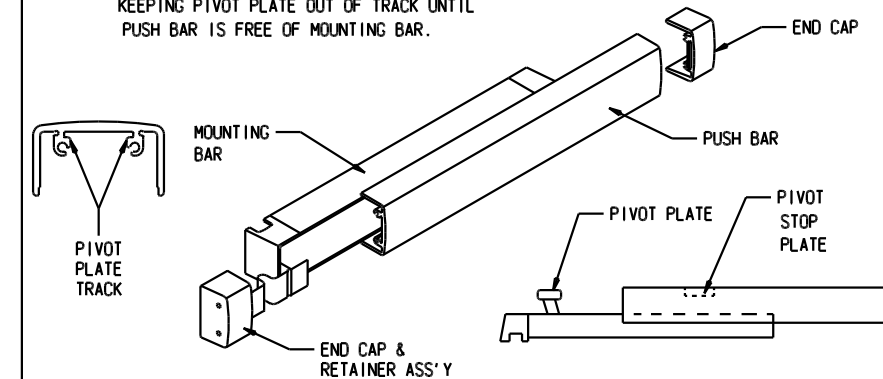

INSTALLING PUSH BAR TO MOUNTING BAR

1. WITH PUSH BAR IN HAND AND MOUNTING BAR ATTACHED TO DOOR, FIND PIVOT PLATE STAKED INTO PUSH BAR. (THIS PLATE IS ON THE LATCH END OF ASSEMBLED UNIT). SLIDE THE PIVOT PLATE NEAREST HINGE INTO TRACK OF PUSH BAR UNTIL SECOND PIVOT PLATE IS EXPOSED. INSERT PIVOT PLATE INTO TRACK ON PUSH BAR AND SLIDE IN OPPOSITE DIRECTION UNTIL PUSH BAR AND MOUNTING BAR ALIGN.

PRODUCT MUST BE INSTALLED ACCORDING TO ALL APPLICABLE BUILDING AND LIFE SAFETY CODES

INSTALLATION
INSTRUCTION
CHECKLIST

ADAMS RITE SERIES 8100 EXIT DEVICE

PRODUCT MUST BE INSTALLED ACCORDING TO ALL APPLICABLE BUILDING AND LIFE SAFETY CODES

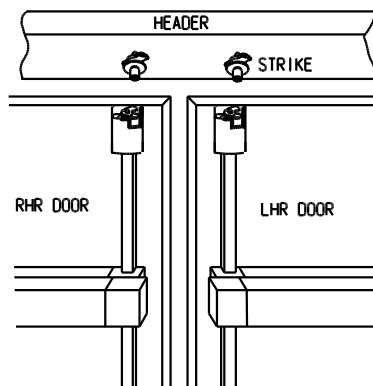

IMPORTANT!

This device is unhanded. It can be installed in either left hand reverse or right hand reverse doors without alteration. The doors' lead stile and header preparation are IDENTICAL *not* mirror image. Note in the sketch above that the yoke type bolt *always* faces right (as viewed from inside) and the strike post is toward the right of the backset centerline for *both* doors.

NOTE STEPS 2 THRU 10 ARE MORE EASILY ACCOMPLISHED IF DOOR IS NOT INSTALLED IN FRAME.

HOW TO FIND BACKSET

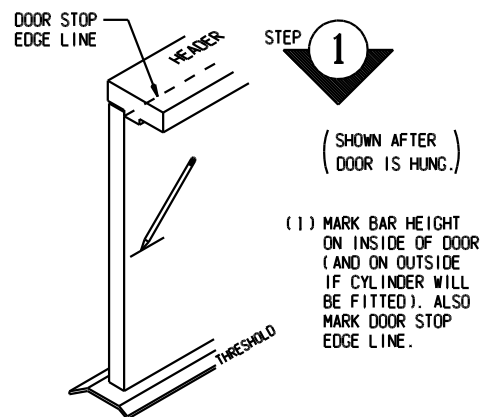
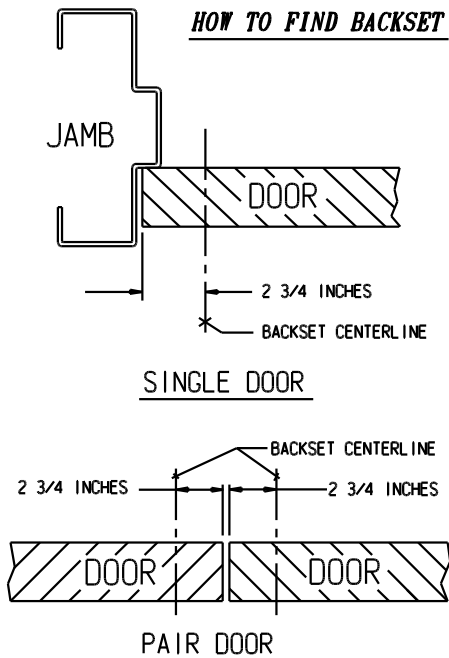

STEP 1
(SHOWN AFTER DOOR IS HUNG.)

(1) MARK BAR HEIGHT ON INSIDE OF DOOR (AND ON OUTSIDE IF CYLINDER WILL BE FITTED). ALSO MARK DOOR STOP EDGE LINE.

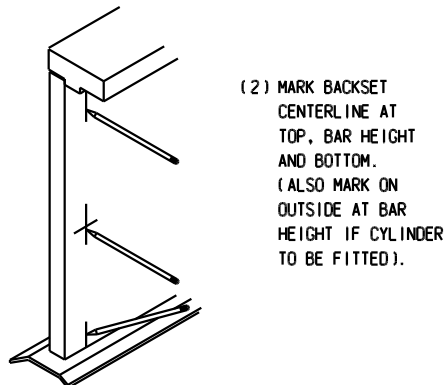

STEP 2

(2) MARK BACKSET CENTERLINE AT TOP, BAR HEIGHT AND BOTTOM. (ALSO MARK ON OUTSIDE AT BAR HEIGHT IF CYLINDER TO BE FITTED).

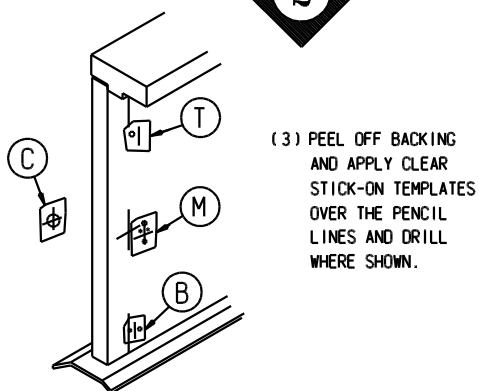

(3) PEEL OFF BACKING AND APPLY CLEAR STICK-ON TEMPLATES OVER THE PENCIL LINES AND DRILL WHERE SHOWN.

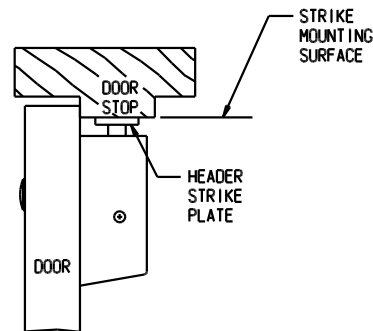

(4) ADJUST RODS TO LENGTH: WITH GEARS ALIGNED TO STAMPED MARKS (SEE FIGURE AT STEP 8), ADJUST TOP ROD TO LENGTH BY TURNING IT TO ALIGN MARK ON TEMPLATE WITH SQUARE BOLT. ADJUST BOTTOM BOLT FLUSH WITH BOTTOM OF DOOR (FOR NOW).

STEP 3
INSTALL 4 SEX BOLTS THROUGH 3/8 DIA HOLES. INSTALL 2 PLASTIC GUIDES ON BACKSET CENTERLINE; ONE HALFWAY FROM BAR HEIGHT TO TOP OF DOOR, ANOTHER HALFWAY TO BOTTOM OF DOOR. (USE ROD GUIDE AS TEMPLATE TO DRILL 1/8 DIA HOLES FOR WOOD SCREWS (FOR WOOD DOOR) OR SELF-TAPPING SCREWS (FOR HOLLOW METAL DOOR).)

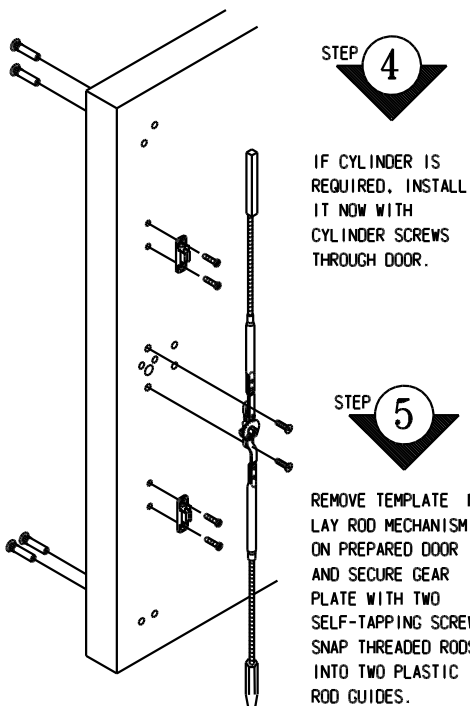

STEP 4

IF CYLINDER IS REQUIRED, INSTALL IT NOW WITH CYLINDER SCREWS THROUGH DOOR.

STEP 5

REMOVE TEMPLATE M. LAY ROD MECHANISM ON PREPARED DOOR AND SECURE GEAR PLATE WITH TWO SELF-TAPPING SCREWS. SNAP THREADED RODS INTO TWO PLASTIC ROD GUIDES.

STEP 6
ADJUST RODS TO LENGTH: WITH GEARS ALIGNED TO STAMPED MARKS (SEE FIGURE AT STEP 8), ADJUST TOP ROD TO LENGTH BY TURNING IT TO ALIGN MARK ON TEMPLATE WITH SQUARE BOLT. ADJUST BOTTOM BOLT FLUSH WITH BOTTOM OF DOOR (FOR NOW).

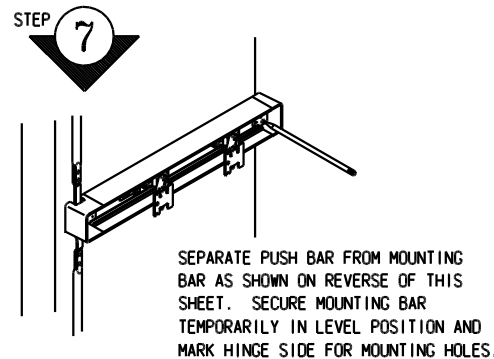

STEP 7

SEPARATE PUSH BAR FROM MOUNTING BAR AS SHOWN ON REVERSE OF THIS SHEET. SECURE MOUNTING BAR TEMPORARILY IN LEVEL POSITION AND MARK HINGE SIDE FOR MOUNTING HOLES.

STEP 8
REMOVE BAR, DRILL 3/8 HOLES IN HINGE SIDE AND INSTALL TWO SEX BOLTS. REINSTALL BAR PERMANENTLY WITH FOUR (4) SCREWS AS SHOWN BELOW.

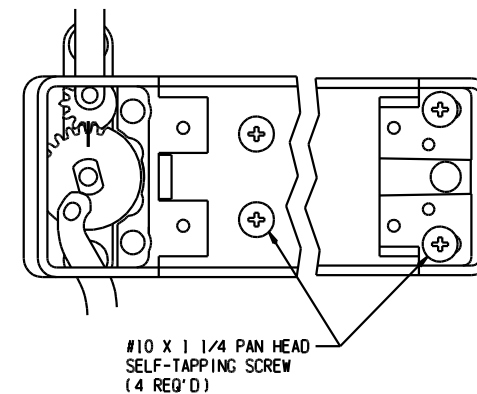

SECURE CRANK ON DRIVER SHAFT WITH LOCK WASHER AND SCREW. THEN REINSTALL THE PUSH BAR.

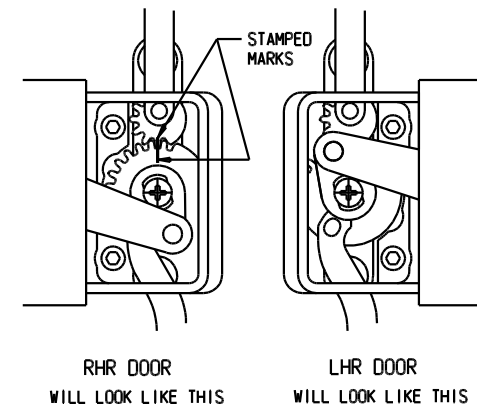

STEP 9

CUT ROD COVER TO LENGTH. INSERT END IN MOUNTING BASE AND CUT AS SHOWN ON STICK-ON TEMPLATES ① AND ②. REMOVE TEMPLATES ① AND ②.

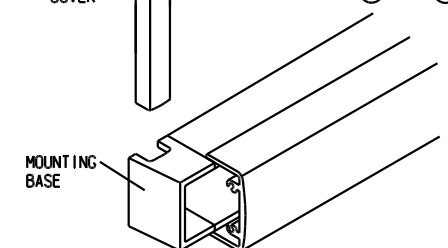

STEP 10
INSTALL TOP BOLT ACTUATOR ASSEMBLY AND SECURE WITH TWO SCREWS. SNAP ROD COVER ONTO PLASTIC ROD GUIDE AND SLIDE IT DOWN INTO MOUNTING BASE. WITH ASSEMBLY IN LOCKED POSITION AND PUSH BAR RELEASED, END OF SQUARE BOLT SHOULD ENGAGE STOP PLATE AS SHOWN. (FOR FINE ADJUSTMENT, REMOVE ACTUATOR ASSEMBLY, ADJUST BOLT UP OR DOWN AND REINSTALL ASSEMBLY.)

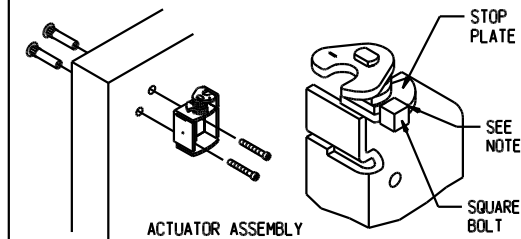

NOTE: SQUARE BOLT MUST BE FLUSH WITH TOP OF STOP PLATE TO 1/16 MAX. BELOW FLUSH.

INSTALL DOOR IN FRAME. MARK ON HEADER, THRESHOLD, THE BACKSET CENTERLINE, AND WHERE EDGES OF CLOSED DOOR REST. APPLY CLEAR TEMPLATES (H) AND (F) AND DRILL STRIKE HOLES.

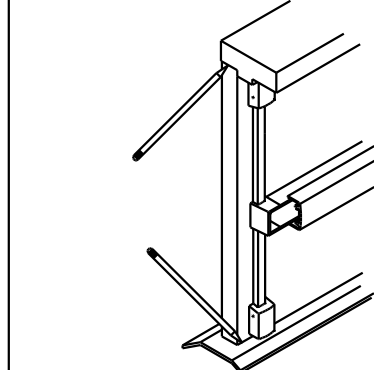

STEP 12

SECURE STRIKE PLATE ON HEADER. POSITION STRIKE PLATE ASSEMBLY ON PLATE, THEN TIGHTEN SECURELY WITH HEX WRENCH. (TORQUE TO 100 IN-LBS MAX.)

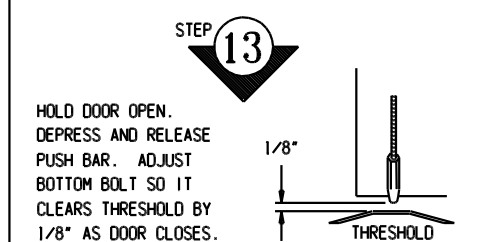

STEP 13

HOLD DOOR OPEN. DEPRESS AND RELEASE PUSH BAR. ADJUST BOTTOM BOLT SO IT CLEARS THRESHOLD BY 1/8" AS DOOR CLOSSES.

STEP 14
INSTALL LOWER COVER. SNAP ALUMINUM ROD COVER ONTO PLASTIC ROD GUIDE AND SLIDE IT UP INTO MOUNTING BASE. SLIP LOWER BOLT GUIDE ASSEMBLY OVER HEX BOLT AND DROP INTO LOWER COVER SHOWN. POSITION LOWER COVER AND SECURE IT WITH TWO SCREWS.

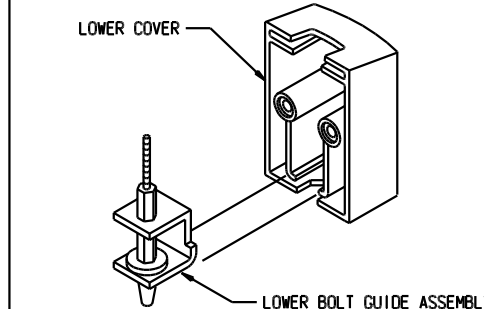

STEP 15

INSTALL TWO PROTECTIVE COVERS ON TOP BOLT ACTUATOR ASSEMBLY AND LOWER COVER. SLIDE PROTECTIVE COVERS INTO TOP BOLT ACTUATOR ASSEMBLY AND LOWER COVER. SECURE EACH COVER WITH ONE SCREW AT SIDE.

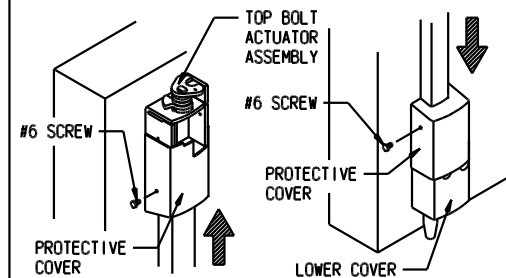

STEP 16

INSTALL PUSH BAR END CAPS

