

# AL500 Series Alarmed Hardware

## Premier Product

### AL500 Series exit alarm

#### Features:

- Microprocessor based alarm board
- When armed, alarm sounds immediately upon rail depression
- All exit devices have tamper resistant latching (Guarded Latch)
- Battery powered - 9VDC
- 103 Db @ 8 ft pulsating horn
- Flashing red LED provides visible violation indication, reset by key only
- Low battery alert
- Field selectable continuous alarm option
- Automatic re-arming option
- Inside cylinder operation to arm or disarm unit uses a 1-1/8" (29mm) mortise cylinder with 001 cam. Cylinder ordered separately.
- UL Listed and cUL Listed
- UL Listed to Canadian Safety Standards
- Rail Monitoring and Guarded Latch are standard internal features
- Minimum door widths: E 32" only, F 32-1/4 - 36", G 36-1/4 - 48"
- See McKinney's Transfer Device Solutions Catalog for QC Hinge and cable requirements (if hard wired)

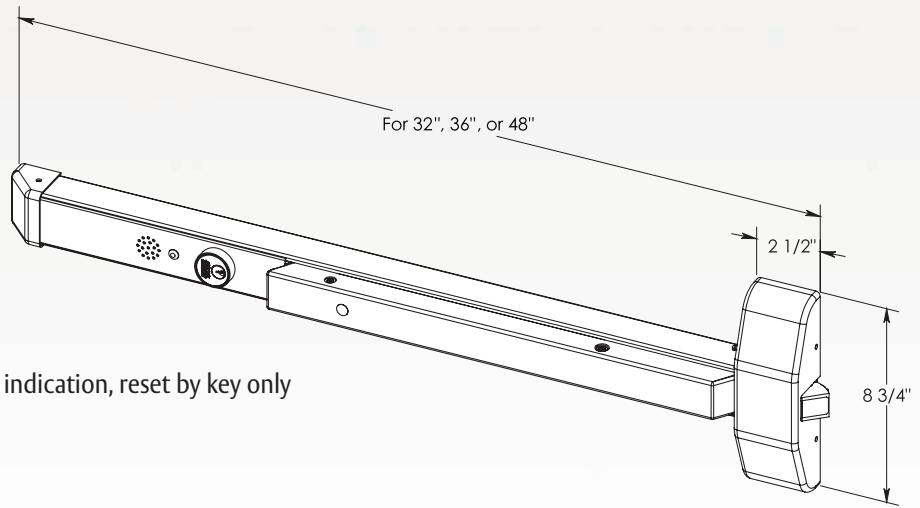

#### Finishes:

630, 689, 690, BSP, RD

#### Certification and Compliance:

Designed to meet ANSI 156.3-1984 and A117.1-1980 for Accessibility Standards.

Packed - 1 each.