

Revolution™ Series Locks		
Backset	Latch No.	Front Dim. A
2-3/8" (60)	380N	1" (25)
2-3/4" (70)	380AN (std)	1-1/8" (29)
2-3/4" (70)	380CN	1" (25)

Notes:

- Do not scale drawing
- For strike preparation refer to:
371 Strike - Template No. 7102-0005
497 Strike - Template No. 7102-0003
- Backset: 2-3/4" (70mm) standard
2-3/8" (60mm) to order
- For wood door preparation refer to
Template No. 7150-8017
- Door manufacturer must provide supports within the door to keep the door from collapsing when lock is installed. Back of latch case must also be supported.
- All dimensions given in inches (mm).

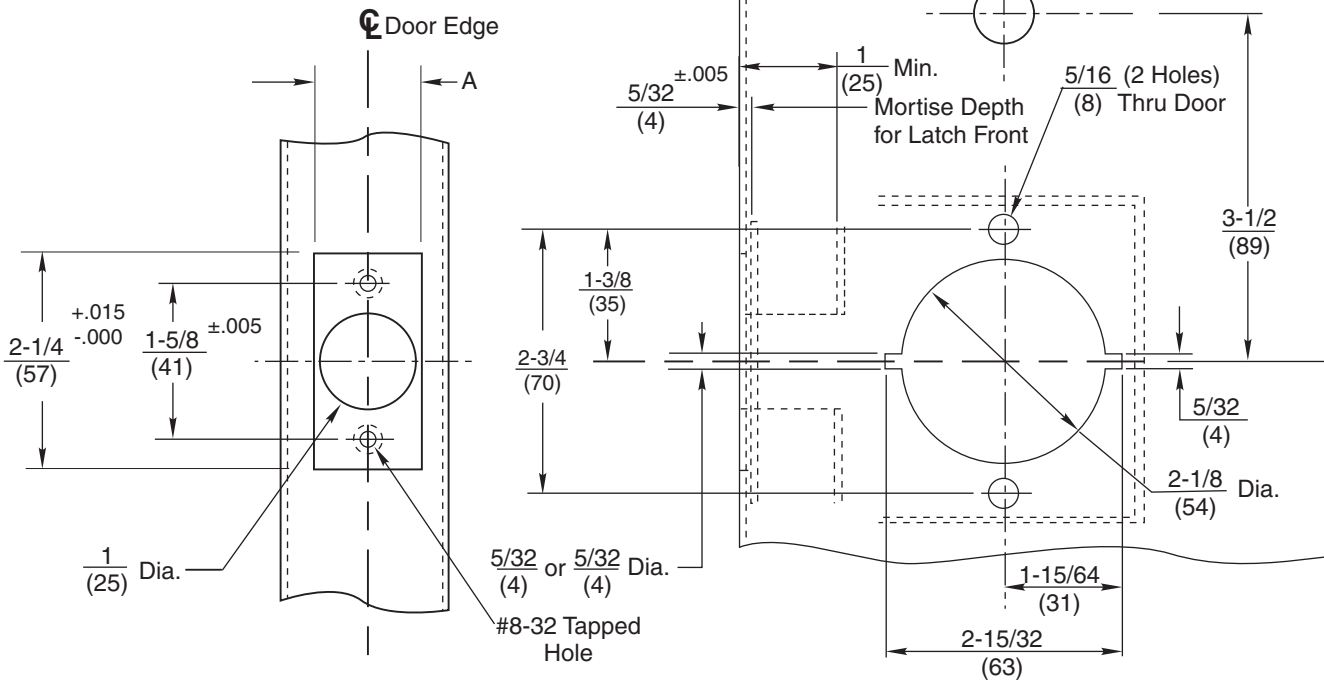
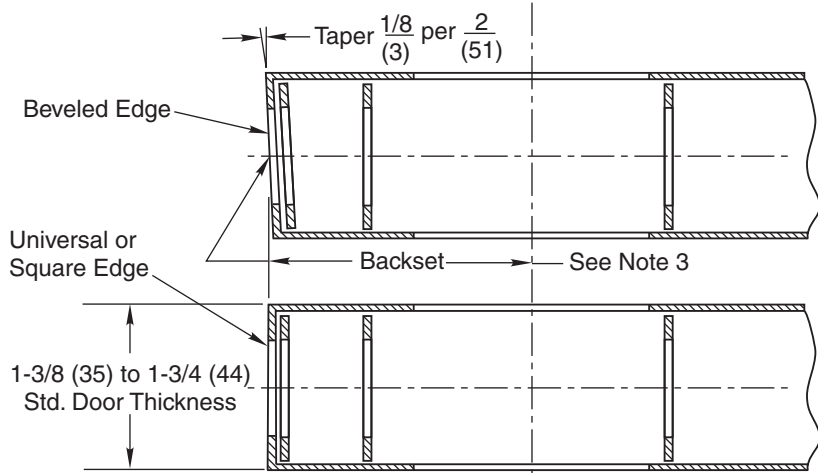

**Revolution™ Stand-alone Touchscreen Access Locks
H.M. Door Preparation
2-3/8" (60mm) and 2-3/4" (70mm) Backsets**



3625 Allegheny Dr
Salem, VA 24153
1-800-839-3157

ASSA ABLOY

www.arrowlock.com

TEMPLATE NUMBER

V1TEMPL-HM

DATE

07-09