

## CORMAX™ Specification Data

CORMAX™ is a premier patented keying system that meets all of your needs for higher security, key control, and convenience.

### X Series Keyway Features

- X Series keyways are unique to CORMAX™ offering even higher key duplication protection.
- Thicker key blanks with larger bow for added strength and easier handling.
- Recommended for large facilities in multi-building campuses.

### M Series Keyway Features

- Four keyways in one family.
- M Series CORMAX™ keys operate both CORMAX™ and BEST® standard cores (backward compatibility) with J, K, L, and M keyways. BEST® standard keys do not operate CORMAX™ cores.
- Available in large bow, long blade, and long nose key blanks to work with special applications.
- Enables seamless, phase-in upgrades in large facilities and multi-building campuses since CORMAX™ cores can be installed in openings demanding higher security while keeping the existing BEST® cores in the remaining areas.

### M Series Backward Compatibility

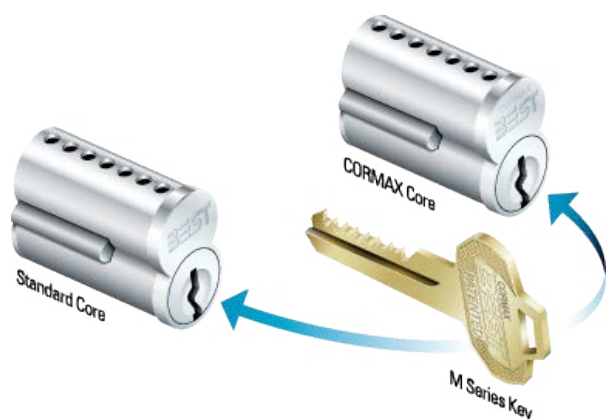

\* Keyway offerings will continue to grow.

\*\* Certain restrictions apply.

\*\*\* Additional charges will apply.

General:	
Core Format	BEST - SFIC
BHMA Standard	A156.5, Grade 1
Utility Patent	2027
Physical:	
Core Material	Brass
Key Material	Nickel-Silver
Finishes (605, 606, 611, 612, 613, 625, 626, 690)	8
Core Size (pin count)	6 or 7
Keyway Count (excluding multi-milling) *	> 30
Key System	A2, A4
Security Levels: **	
(W) Non-exclusive	Available
(X) Two-digit zip code exclusive	Available
(Y) One-digit zip code exclusive	Available
(Z) National exclusive	Available
Features:	
Warranty	3 year limited
Pick & Drill Resistant	Option
Key Trap	Option
Wear Resistant	Option
M series keys are backward compatible with standard J,K,L,M keyways	MJ,MK,ML,MM
Milling (sectional keyways) Capability	Double, Quad
Construction Core to Permanent Keying Support	Yes
Keystone - Key and Core Control Management ***	Service Option
BESTCode - Masterkey System Support	Service Option
Custom Key Stamping ***	Service Option
Packaging (Uncombined Cores and Key Blanks**):	
Single Unit package Dims (L x W x H) - Key	2.5 X 4 1/4 Envelope
Single Unit package Dims (L x W x H) - Core	2 1/4 X 3.5 Envelope
Single unit package weight (lbs) - Cores	.112 lbs
Single unit package weight (lbs) - Keys	X Series: .028 lbs, M Series: .024 lbs
Masterpack count - Cores	50
Masterpack count - Keys	X Series:100, M Series: 144
Masterpack package Dims (L x W x H)	4 1/4" X 4 1/8" X 3" to 3 1/8"
Masterpack Package weight (lbs) - Cores	5.6 lbs
Masterpack Package weight (lbs) - Keys	X Series: 2.88 lbs, M Series: 3.5 lbs

## CORMAX™ Keyway Examples

Shown in the chart below are the single CORMAX™ keyways and their multi-milling (sectional) options. CORMAX™ offers 32 unique keyways, 128 level options, and continues to grow and evolve.

Keyways	Single	Single	Single	Single	Double	Double	Quad
<b>M Series</b>	MJ	MK	ML	MM	MJK	MLM	MJLKM
<b>X Series</b>	XA	XB	XC	XD	XBA	XDC	XDCBA
	X1	X2	X3	X4	X5	X6	X7
	X8	X9	X10	X11	X12	X13	X14
	X15	X16	X17	X18	X19	X20	X21
	X22	X23	X24	X25	X26	X27	X28
	X29	X30	X31	X32	X33	X34	X35
	X36	X37	X38	X39	X40	X41	X42

Keyway offerings will continue to grow.



### Keyway Family Example

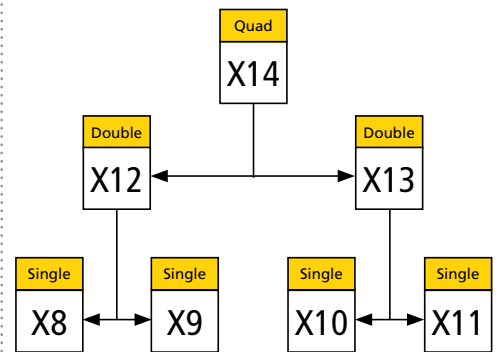

**Single** - Available on keys and cores  
**Double/Quad** - Available on keys only

For more information on the CORMAX™ offering please contact customer service at 1-855-365-2407.