

CM0340 TOP PIVOT, CENTER HUNG, NON-HANDED WITH CONCEALED MAGNETIC MONITOR SWITCH

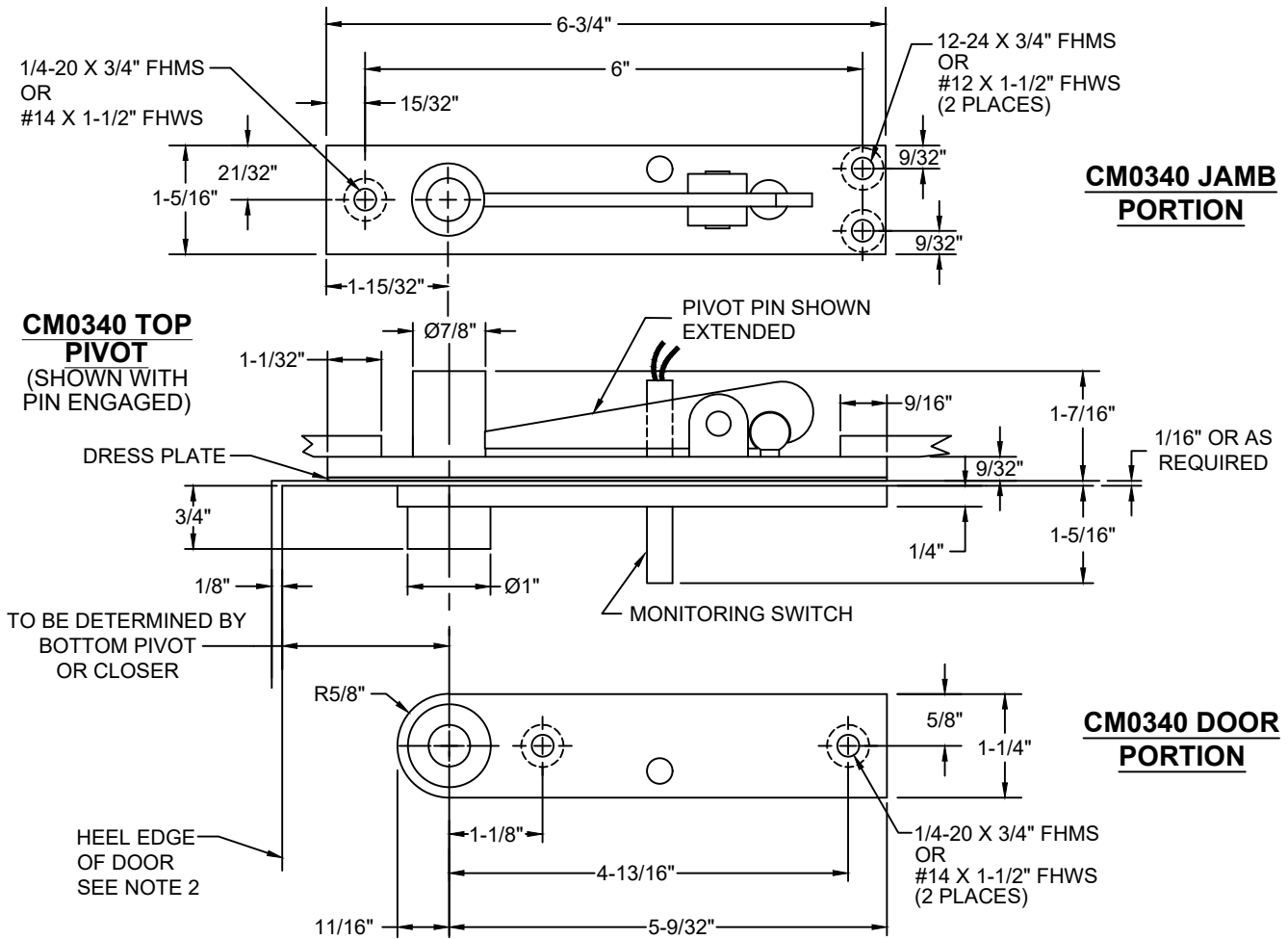

NOTES:

1. REINFORCING BY OTHERS.
2. RADIUS HEEL EDGE OF DOOR 1-1/4" MAX FOR 1-3/8" - 2-1/2" THICK DOORS
3. IT IS THE DOOR AND FRAME MANUFACTURERS RESPONSIBILITY TO CHECK THE HARDWARE SCHEDULE AND PREP THE DOORS AND FRAMES.
4. CENTERLINE OF TOP PIVOT PIN MUST BE PLUMB AND STRAIGHT WITH BOTTOM PIVOT OR CLOSER SPINDLE.

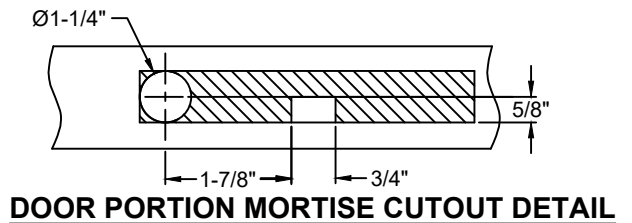
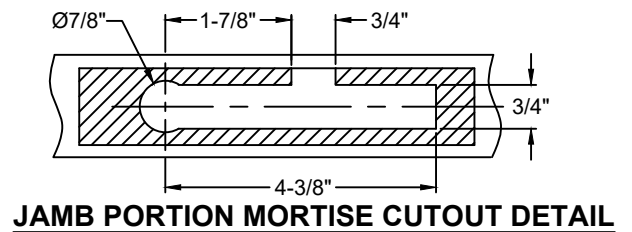

Disclaimer: This template is to be used for installation, as shown, of said product and is not suitable for every application method. Custom applications, where door sizes, weights and conflicting hardware are a factor, need to be addressed with ABH and proper instructions provided. ABH is not liable for failure or performance of the product due to improper installation methods and/or use. Improper use and/or installation of this product will void the standard warranty.

CM0340-01.DWG



www.abhmfg.com
E-mail: abhinfo@abhmfg.com
Architectural Builders Hardware Mfg., Inc.
1222 Ardmore Ave., Itasca, IL 60143
630.875.9900; FAX 800.9FAXABH (932.9224)

© 2020 ABH Mfg., Inc.
printed in USA

CM0340

PAGE 1 OF 1

REVISED 10-21-20