

CR4594, 5-3/4" DOUBLE LIPPED STRIKE AND RESCUE DOOR STOP
FOR 1/8" INSET HUNG DOOR

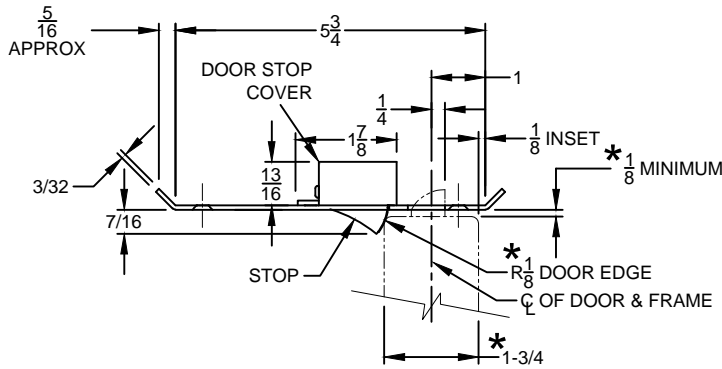

TOP VIEW

STOP IS SPRING LOADED
MAKING PART NON-HANDED
BUT INSTALLATION IS
STILL HANDED

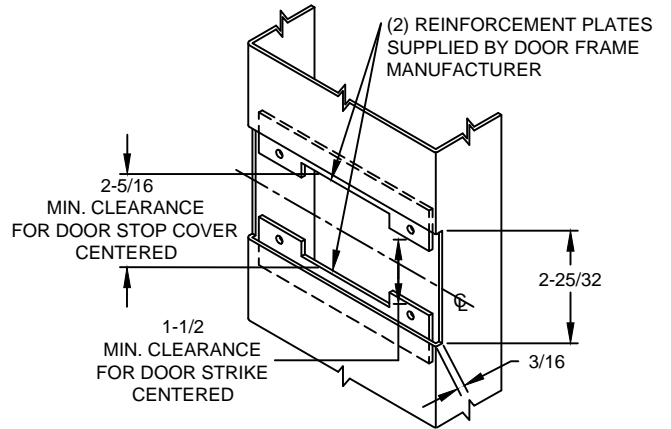

CUT-OUT FOR
METAL JAMB

COUNTERSUNK FOR #8
FLAT HEAD SCREW (4 PLACES)

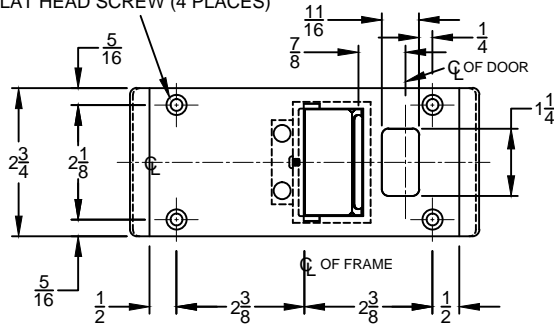

FRONT VIEW

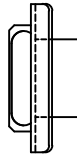

SIDE VIEW

NOTE:

1. HORIZONTAL CENTERLINE OF PLATE TO MATCH HORIZONTAL CENTERLINE OF CUTOUT.
2. SCREWS- 8-32 X 3/8" UNDERCUT F.H.M.S.
3. R.H. DOOR SHOWN, L.H. OPPOSITE
4. DO NOT SCALE DRAWING.
5. FOR CUSTOM RESCUE DOOR STOP CONSULT FACTORY.

REINFORCEMENT:

WHEN INSTALLING IN METAL FRAME, REINFORCEMENT IS **NEEDED** WITH THIS PRODUCT, CUSTOMER OR MANUFACTURER TO SUPPLY FRAME REINFORCEMENT WITH LATCH BOLT CLEARANCE.

ABH CR4594 RESCUE STOP IS DESIGNED FOR USE WITH CYLINDRICAL BORED LOCKS SETS AND MAY NOT WORK PROPERLY WITH SOME MORTISE LOCKS OR MORTISE LOCKS WITH THE DEAD LATCH. CONSULT FACTORY FOR MORTISE LOCK APPLICATIONS.

* = CRITICAL DIMENSION MUST BE FOLLOWED



www.abhmfg.com
E-mail: abhinfo@abhmfg.com
Architectural Builders Hardware Mfg., Inc.
1222 Ardmore Ave., Itasca, IL 60143
630.875.9900; FAX 800.9FAXABH (932.9224)

©2009 ABH Mfg., Inc.
printed in USA

CR4594

ISSUED 03-09-09