

CX-PS600UL

POWER SUPPLY / CHARGER

INSTALLATION INSTRUCTIONS

1. DESCRIPTION

The CX-PS600UL series of power supply/charger supplies a total of 6-amp nominal continuous supply current @ 12/24V DC outputs. It is installed in a large sheet steel enclosure capable of accommodating one or two 12Ah lead acid rechargeable batteries. The Camden CX-PS600UL has been evaluated for ULC-S533, UL294 and ULC-60839-11-1. This Power supply is not intended to power fire notification appliances (Horns, Strobes & Bells).

2. GENERAL SPECIFICATIONS

1. Input = 120 240V AC 50-60Hz, 2.5 Amp maximum, fuse at 6 Amp
2. Output 6 Amps continuous supply current PF 0.6 a t nominal 12/24 V DC.
3. Built-in dedicated charger for sealed lead acid or gel cell type batteries.
4. Maximum battery charging current 1.5Amps (not part of the max output current rating).
5. Automatic switch over to stand-by battery upon AC failure or below 72.5V AC.
6. Battery presence detection within 10 seconds.
7. Temperature Compensated Battery Charger. (EN54-4 only, not UL evaluated)
8. Battery Charger Monitor. Battery load test every 48hr.
9. Battery test result indication.
10. Battery Reversal protection.
11. Low Battery indication at 11.40/22.80 Volts.
12. Low Battery disconnect at 10/20.2 Volts.
13. Low Battery, Battery disconnect, No Battery presence, battery
14. charger trouble reporting. (See FAULT TABLE)
15. AC input indication by Green LED. (LED on when AC is present).
16. AC Fault CMOS Relay contact for AC failure
17. LEDs display on enclosure door (Green, Yellow, Blue).
18. DC output indication by Blue LED, on board and enclosure.
19. Overload and short circuit protection on DC output.
20. Battery charging leads included.
21. Board Dimension: 195mm x 110mm
22. Enclosure Dimension: 338 x 448 x 110mm (HP346 for 12Ah Battery)

CX-PS600UL. POWER SUPPLY / CHARGER

INSTALLATION INSTRUCTIONS

3. TECHNICAL SPECIFICATION:

Output Voltage Output Amperage Ripple	12/24 Vdc Regulated ClassE, unsupervised 6 Amp 50mVp-pmax
Charging Current Battery Charging Voltage	1.5A Max, and not part of max output rating 13.8V/27.6V Nominal
Operating Temperature	0 °C to 49 °C

4. PERFORMANCE RATINGS

UL294 Performance Levels:

Model	Product Type	Line Security	Destructive Attack		Standby Power
CX-PS600UL	Power Supply	I	I	IV	III (when used with 12Ah battery) "output is limited to maximum 4 Amps" III (when used with 17.2Ah battery.)

5. LED INDICATIONS

1. Green LED- AC indicator

- On when AC present.
- The AC fail Relay activates (opens) within 60 seconds after AC failure.

2. Blue LED- DC Power indicator

- Powered directly from the power supply DC output and indicates output is present.

3. Yellow LED- Battery Charging and Fault indicator

- The Yellow LED flashing indicates the battery is charging and is also used to indicate various Fault conditions. See the Fault Condition and Indication table for details.

4. Red LED- Battery/ Charger test Indicator for Pass or Failure.

- The Red LED indicates a Battery test Failure or a Battery charger failure in conjunction with the Yellow LED to indicate other Fault Conditions. See the Fault Conditions and Indication table for details.

6. RELAY / OUTPUTS:

Output	Output Type	Description
AC FAIL	NORMALLY CLOSED OPEN = FAULT	TRIPS WITHIN 60 SEC. AFTER AC FAILS CMOS RELAY RATING : 30V DC 60mA 16 Ω
BATTERY FAIL	NORMALLY CLOSED OPEN = FAULT	BATTERY PROBLEM CMOS RELAY RATING : 30V DC 60mA 16 Ω

7. FAULT CONDITION & INDICATIONS:

FAULT	LED-G	LED-Y	LED-R	BATT RELAY	AC RELAY	LED-B
BATTERY REVERSED OR NOT CONNECTED		ON		OPEN		
BATTERY LOW		ON		OPEN		
BATTERY DISCONNECTED		ON		OPEN		
BATTERY TEST FAIL		ON	5 RAPID FLASHES STOP 1 SECOND REPEAT UNTIL BATTERY IS REPLACED	OPEN		
BATTERY TEST OK		OFF	3 FLASHES 1 SEC ON/OFF			
CHARGER FAIL			10 RAPID FLASHES 2 SECONDS STOP AND REPEAT UNTIL OK	OPEN		
AC FAIL	OFF				OPEN WITHIN 60 SEC	
DC FAIL / OVERLOAD						OFF

8. BATTERY OPERATING VALUES

Parameter	Output	Description
Battery Disconnect voltage	10/20.2V	When AC is off, the battery is disconnected when the battery voltage drops below this value. The battery is only reconnected when the AC is restored.
Minimum battery voltage to pass battery test	11.50V 23.0V	Red LED should flash for 1 sec ON/OFF during 2 minutes testing. 5 rapid flashes and 1 second pause indicates battery failure. In such case replace battery.
Low Battery Voltage Warning	11.40V 22.80V	If the output voltage drops below this value, a voltage low warning is generated. See Fault Conditions and Indication table.

9. INSTALLATION INSTRUCTIONS

This power supply should be installed in compliance with National Electrical Code, NFPA70 as well NFPA72 National Fire Alarm Code, CSA C22.1, Safety Standard for Electrical Installations, Canadian Electrical Code, Part I, CAN/ULC-S524, and all applicable Local Codes. Installation to be performed by suitably qualified personnel. The power supply shall not be installed in the fail secure mode unless permitted by the local authority having jurisdiction, and shall not interfere with the operation of Listed panic hardware.

NOTE: Connect the Mains AC input 120/240VAC as shows in the installation diagram. Entry knocks out on the left of the enclosure. Keep low voltage wiring away from the AC wiring.

1. Mount the power supply in the desired location using the 4 mounting holes. NOTE: For use in indoor protected area with controlled environment only. Do not install power supply on exterior doors.
2. With the main power disconnected, connect the LEDs to the AC input terminal block, respecting the wiring phase and polarity : Ground/Earth=Green/Yellow, Neutral = Blue (White), Live =Black (Brown). This equipment must be connected to the 120-240 Volt Mains via a readily dedicated accessible external disconnect device with maximum 15 Amp branch protection. Select the operating output DC voltage 12/24 with the jumper SW1. SW1 ON = 12V DC, SW1 OFF = 24V DC.
3. Do not connect the battery at this time.
4. Switch ON the AC power supply and with that Green LED will turn ON indicating AC is present and the AC Fault Relay will be energized "ON" (closed). When the AC is off, the AC Fault Relay will drop open within 60 seconds (Factory set) activating the CMOS output "AC Fail". Connect this output to relevant monitoring devices.
5. Verify the DC output voltage. It should be 13.20V DC or 26.40V DC (max). Blue DC LED will turn ON indicating DC output is OK.
6. Yellow LED will only turn on along with open BAT FAULT CMOS relay to indicate the Battery is not attached or connected with reversed polarity.
7. Connect the Battery or Batteries with respective polarity. Note: Battery should not be connected if the AC is not present first.
8. If the battery is connected with the correct polarities, the Yellow LED will turn OFF (See Fault Conditions and Indications Table). Within one minute the Battery Fault Relay will restore and the Yellow LED will flash once every 2 seconds.
9. If the battery is connected with reverse polarity, the Yellow LED will remain ON. (See the Table Fault). The CMOS relay will be open indicating Battery Fault. Connect this output to relevant monitoring devices.
10. Connect the devices to be powered to the output terminals marked "Vo- Vo+".
11. See below Fig 1 & Fig 2. for installation of PD4ECB, PD8ECB, MOM8ECB and ACM4ECB need 2 EOLR Resistors (2K2) provided.
12. If Tamper Switch is required, use part # TSW1-02 or TWS2-02 (Refer Fig 3).
13. Use 2K2 EOLR (End Of Line Resistor) Part #EORL-PWX2K2.
14. Connect the fault relays to FACP or ACP for trouble indication.
15. Secure the enclosure with the screw or with the Key Lock (if provide).

10. ACM8ECB

DESCRIPTION:

The ACM4ECB is a distribution controller to be used with card Access Control, Egress Doors. It provides 12/24V DC through 8 outputs rated 2.0A (max. 6A total) each with electronic over-current protection set at 2.5A. The 8 outputs will switch ON or OFF security devices such as Magnetic Locks, Door Strikes, etc. It is connected to FACP or ACP via NO or NC configurable contact input using 2K2 EOLR (Part #EORL-PWX2K2). It also has an input for Reversed Polarity triggering. The ACM4ECB has 2 Dry Contact "Form C" relay outputs, one is to indicate output status, and another to indicate DC failure on any of the 4 outputs, due to overcurrent or short.

Installation:

1. Output Connections

There are 8 selectable outputs suitable for FAIL Safe config and Fail Secure config.

a) For FAIL Safe Operation, connect the positive (+) lead of the device to normally closed (NC) and the negative lead to COM "Neg", connector CN1 to CN8. DC power is present in normal condition and switched OFF when the fire alarm FACP/ACP or Reverse Polarity input is triggered. Fail Safe operation devices such as, Magnetic Lock should be connected to this output as show in Fig. 2.

b) For For FAIL secure operation, connect the positive(+) lead to Normally Open (NO) instead of normally closed (NC). DC power is not present in normal condition and will switch ON when the FACP or ACP or Reverse Polarity input is triggered. FAIL secure operation devices such as Door Strikes should be connected to this output.

2. Fire Alarm and Access Control Interface

Normally Open (NO), Normally Closed (NC) input or Polarity Reverse (Rev. Volt.) input are available to trigger the ACM8ECB operation. Connect the positive(+) and Negative(-) from the FACP or ACP to the REV. VOLT terminals observing the polarity, (polarity is referenced in alarm condition) or connect the NO or NC from the FACP or ACP output to the "Fire Trigger" terminals. Install PWX2K2 2k2 (EOLR) resistor at the FACP or ACP as show in Fig. 1. Note: No ELOR on Rev. Pol.

3.Engineering RESET/REX Input

This option is available when the Jumper JL is removed (JL OFF). This will cause the ACM4ECB to latch upon receiving Input from the FACP or ACP with this option in place and when the FIRE/ACP TRIGGER resets, ACM8ECB will only reset by activating the RESET/REX input.

JL ON will cause the unit to follow the FIRE/ACP TIGGER. Install PWX2K2 2.2K (EOLR) resistor at the Key Switch or Push Button to perform this operation.

4. Relay Output

a) DC Fail: When one or more of the 8 outputs fail due to over current or short circuit condition, the DC fail Relay will open. Connect this output to monitoring device. (28V DC, 300mA)

b) Status Outp: ut: When the FACP or ACP input activates this will cause the dry contact Relay Form "C" to change state (de-energize). Connect this output to monitoring device. (28V DC, 300mA)

5. Cascade Connection

Two (2) or more ACM8ECB units can be connected together as follow: Connect the Status Output relay C and NC terminals from the 1st unit to the REMOTE RESET/REX INPUT of the 2nd unit(not polarity sensitive) and remove the JR of the 1st unit. Install EOLR(2K2) on 2nd unit Fire Trigger terminal. If 3rd unit is connected, the JR of the 2nd unit must be removed, and so on for any additional unit. Ref to Fig.1.

NOTE: If Latch Mode is used, only JL jumper on the first unit must be removed. Engineering Reset will be performed from the 1st unit.

6. ACM8ECB LED INDICATION

L1 to L8 are the Output RED LEDs, when ON they indicates DC is present (enable), and the Output relays are energized.

When OFF, they indicate Relay is de-energized and the output is OFF, NO DC present (disable). LD1 to LD4 Yellow LEDs. They indicates overload or short on the output. The output current limit is set @ 2.5Amp, rated at max 2.0Amp. L9 Green LED is normally OFF. It will switch on upon receiving an alarm from the FACP/ACP. This LED will stay ON following the status of the FACP/ACP input. If JL was removed this LED will stay ON until the manual RESET circuit resets.

CX-PS600UL. POWER SUPPLY / CHARGER

INSTALLATION INSTRUCTIONS

7. Access Control Panel (ACP) Trigger input.

There are 8 inputs, split between CN10 to CN13 each with four terminals, two IN and two GND. Activation of the inputs is achieved by shorting IN and GND terminals of the respective inputs.

8. FACP/ACP Input Programming

Selectable Output to be Irrelevant on Fire Activation To have the output relay activation follow the FACP or ACP input place the DIP switch corresponding to desired relay to the "OFF" position. In the "ON" position, the correspondent output relay will not be affected by the FACP, ACP or Rev. Pol input.

9. Isolated Output Configuration

If any of the outputs requires to be Isolated DRY CONTACT, remove the respective Jumper J1 through J8 to achieve this configuration, Form "C", (C NO NC) available to connectors CN1 through CN4. This connection is now isolated from the internal power source. Relay Rating: 28V DC, 2A. PF 0.6.

CX-PS600UL

REGULATED POWER SUPPLY CHARGER
UL/ULC LISTED AS FOLLOWS:
UL294, CAN/ULC-60839-11-1, CAN/ULC-S533
POWER SUPPLY FOR ACCESS CONTROL SYSTEM

This Product must be installed in compliance with Article 760 of the National Electrical Code NFA70, and all applicable codes. CSA C22.1, Safety Standard for Electrical Installations, Canadian Electrical Code.



NOTE: PLEASE REFER TO DX600UL INSTALLATION MANUAL PART NO:PX6000 REV:01

PART NO:PX6004 REV:01

DATE OF MFG:



I.T.E. POWER SUPPLY
E220695



REG# T1880468-02



REG# T1880468-01



REG# T1880468-03

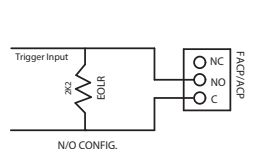
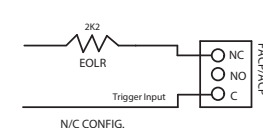
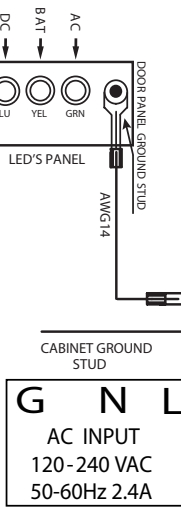
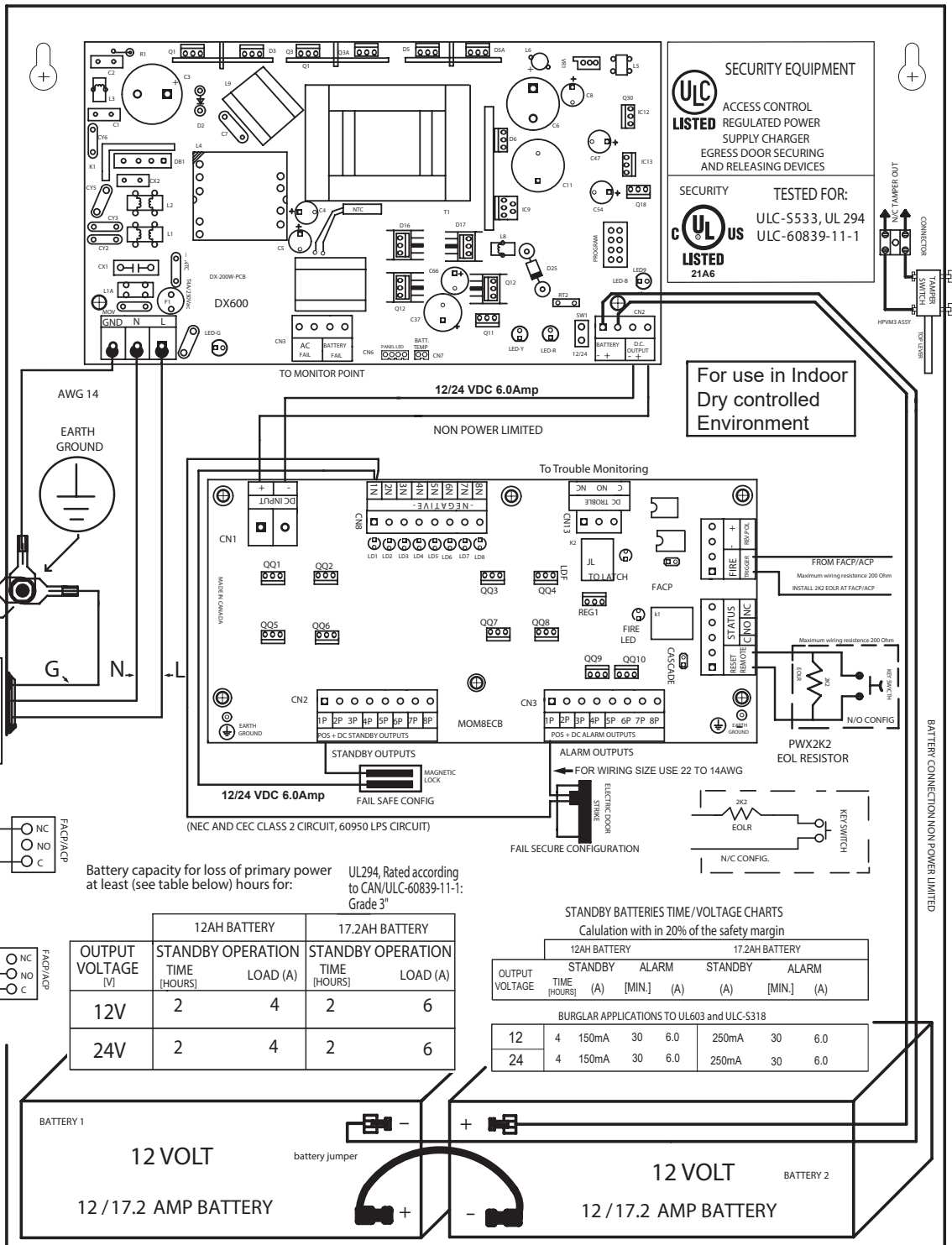

Battery capacity for loss of primary power at least (see table below) hours for: UL294, Rated according to CAN/ULC-60839-11-1: Grade 3

OUTPUT VOLTAGE (V)	12AH BATTERY		17.2AH BATTERY	
	STANDBY OPERATION TIME (HOURS)	LOAD (A)	STANDBY OPERATION TIME (HOURS)	LOAD (A)
12V	2	4	2	6
24V	2	4	2	6

STANDBY BATTERIES TIME/VOLTAGE CHARTS
Calculation with in 20% of the safety margin

OUTPUT VOLTAGE	12AH BATTERY		17.2AH BATTERY	
	STANDBY TIME (HOURS)	ALARM (A)	STANDBY TIME (HOURS)	ALARM (A)
12	4	150mA	30	6.0
24	4	150mA	30	6.0

BURGLAR APPLICATIONS TO UL603 and UL-5318

TIME (HOURS)	12AH BATTERY		17.2AH BATTERY	
	ALARM (A)	STANDBY (A)	ALARM (A)	STANDBY (A)
12	4	150mA	30	6.0
24	4	150mA	30	6.0

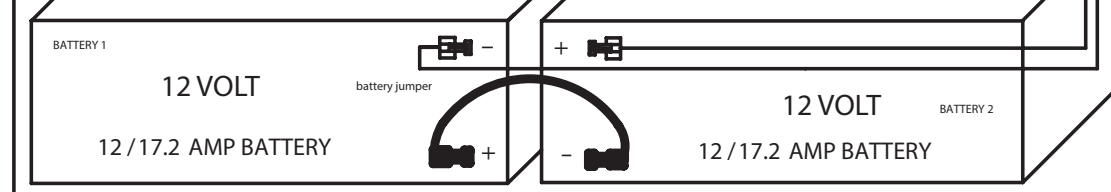

KEEP POWER LIMITED WIRING FROM NON POWER LIMITED WIRING AT LEAST 0.25" INCH APART

Fig. 1

TYPICAL SUGGESTED APPLICATION WIRING DIAGRAM

2 OR MORE CX-PS600 CONNECTED IN CASCADE PART

NO:PX6007 VER:01

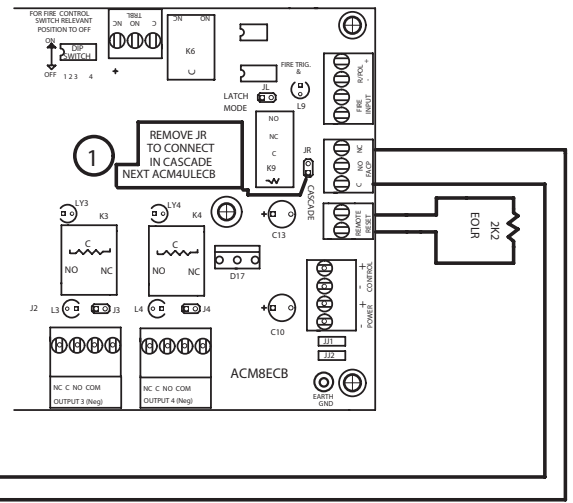
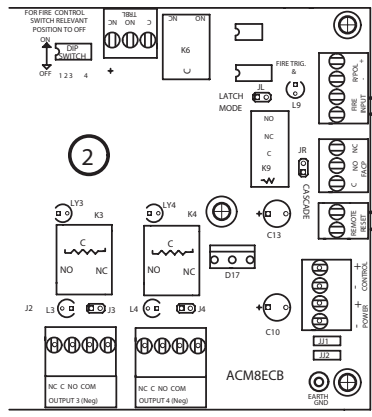
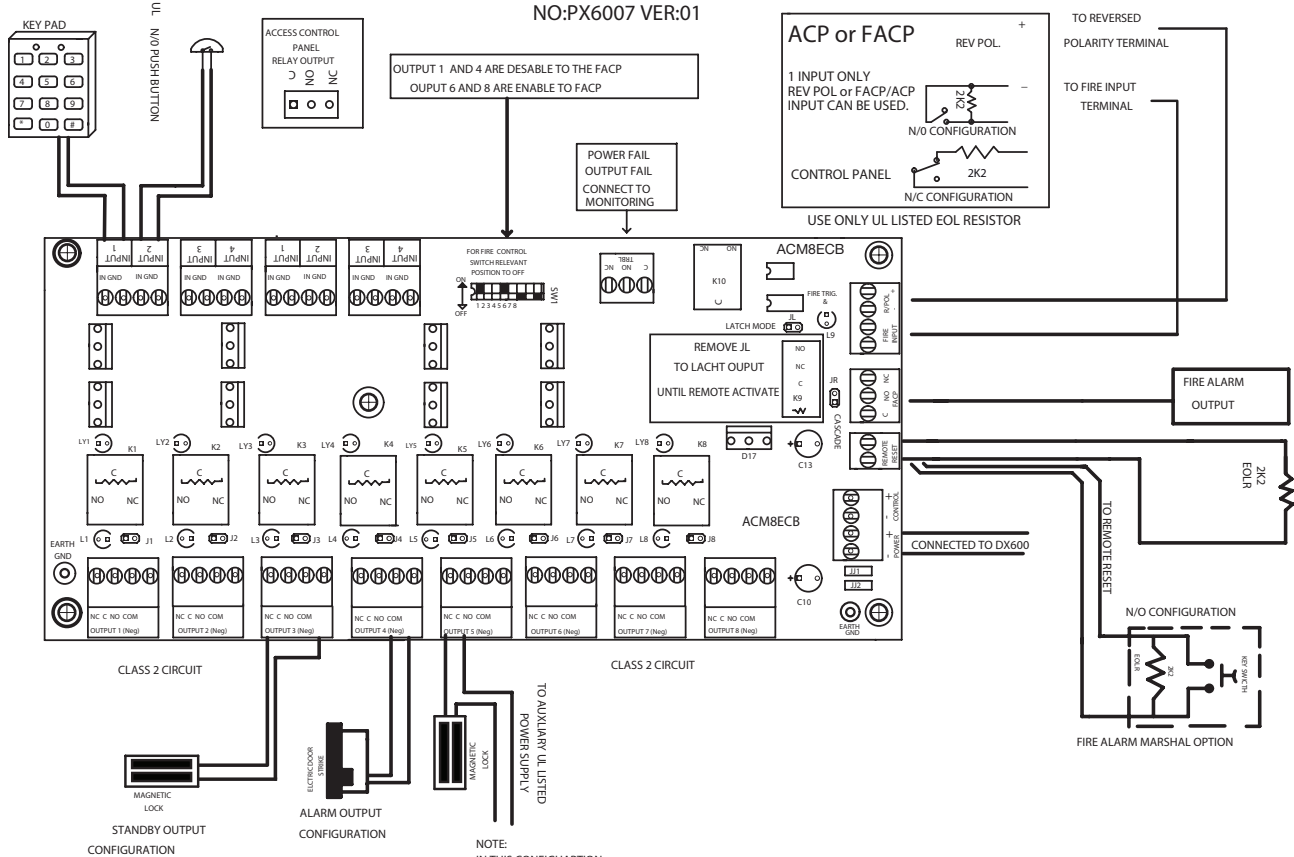

KEEP POWER LIMITED WIRING AT .25" MINIMUM SPACING

Fig. 2

Tamper Switch Connection

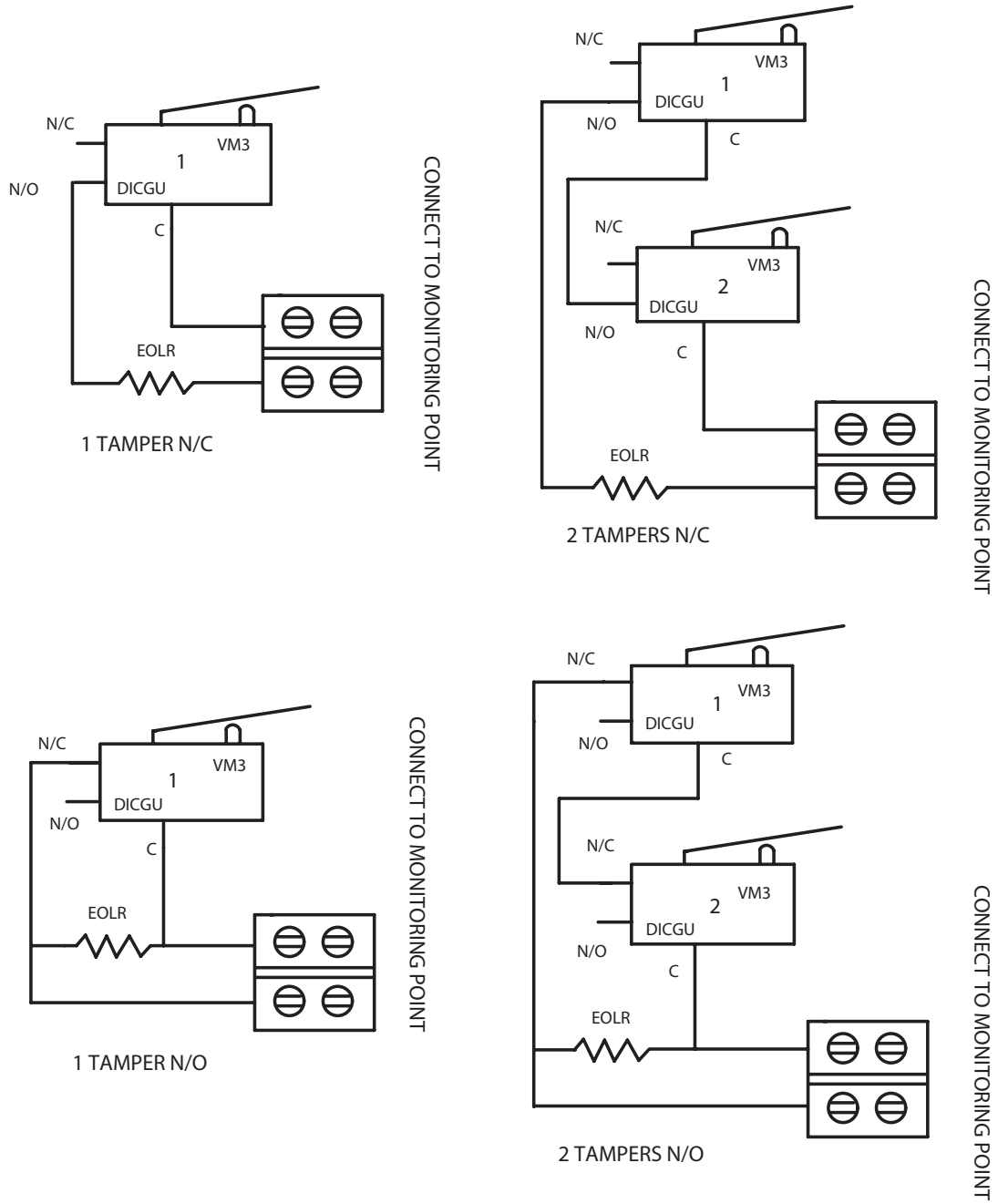

Fig. 3