

CX-ED1309 Series

Electric Strike

INSTALLATION INSTRUCTIONS



THIS PACKAGE INCLUDES:

- | | |
|--------------------------------|-------------------------|
| 1- 4 PIN power connector (12V) | 4- #10-24 x 1/2" screws |
| 1- 4 PIN power connector (24V) | 2- Mounting brackets |
| Faceplate(s) included | 1- Varistor |
| 4- Wire nuts | 1- Dress Plate |
| 2- #10 x 1 1/4" wood screws | |

1. DESCRIPTION

Camden CX-ED1309 Series Grade 1 ANSI strikes for cylindrical locksets offer the very best strike quality and performance. The 'Universal' strike design delivers unparalleled application flexibility, with field selectable voltage, fail safe/fail secure operation for use in aluminum jambs and stiles.

2. SPECIFICATIONS

Voltage	12/24V AC/DC
Current Draw	260mA@12V DC 150mA@24V DC
Static Strength	1,500 Lbs.
Dynamic Strength	70 Ft-Lbs.
Endurance	1,000,000 Cycles (Factory Tested) 250,000 Cycles (UL Verified)
Mode	Field Selectable Fail Safe/Fail Secure
Operation	AC-Buzz, DC-Silent
Duty	Continuous
Dimensions (Body)	4 7/8" H x 1 11/16" W x 1 5/8" D (124mm x 43mm x 42mm)

UL 294 Performance Levels

- Line Security = Level I
- Attack Level = Level I
- Endurance Level = Level IV
- Standby Power = Level I

3. DIMENSIONS

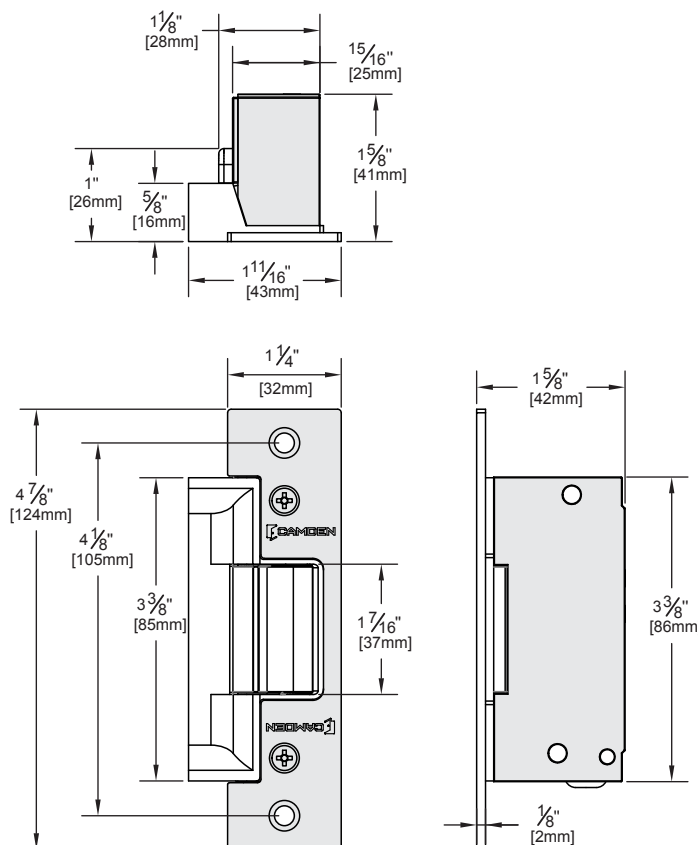

CX-ED1309 Series Electric Strike

INSTALLATION INSTRUCTIONS

4. INSTALLATION

1. Prepare the door jamb as per the appropriate drawing.
2. Install mounting brackets to jamb using #10-24 screws and pressed metal nuts. Do not tighten.
3. Connect wires coming from the low voltage side of the transformer to wire (black) from strike.

4. Install electric strike jamb by attaching #10-24 screws and lockwashers.
5. Secure #10-24 screws holding mounting brackets to jamb.

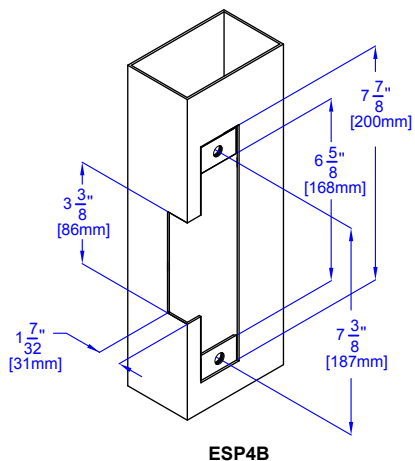
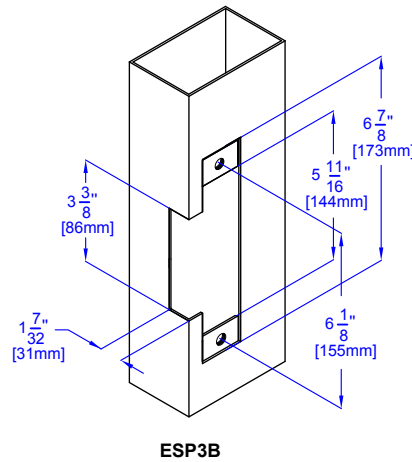
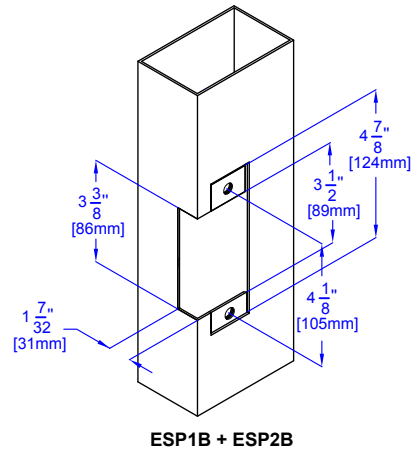
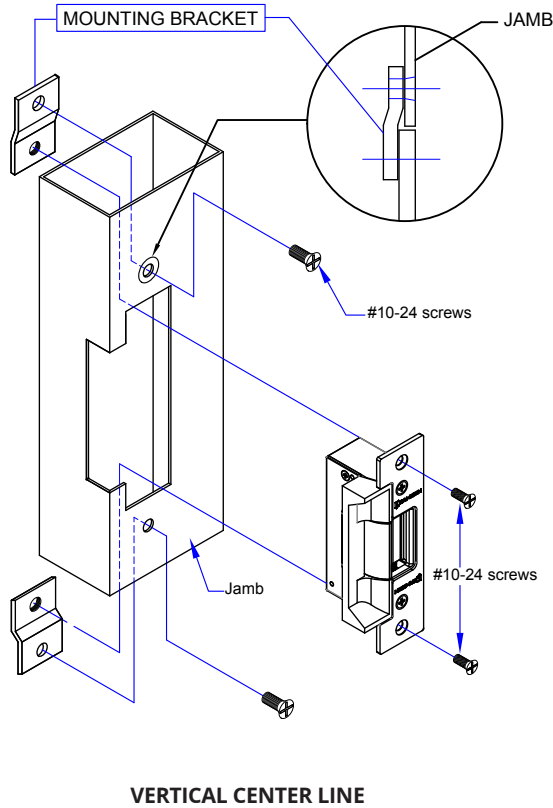

Note: The products are intended to be installed in accordance with the installation wiring diagram, mechanical assembly drawings provided with each product, the local authority having jurisdiction (AHJ) and the electric code, NFPA 70. When installed in fail secure mode, the local authority shall be consulted with the regards to the use of possible panic hardware to allow emergency exit from the secure area.

The electric door strike shall be installed in such a way and in such a location so as to not impair the operation of an emergency exit device or panic hardware mounted on the door.

5. CONNECTIONS

POWER

12V AC/DC

Red/Black: +12V
 Blue/Green: Ground

24V AC/DC

Red: +24V
 Black/Blue: -
 Green: Ground

A varistor is provided to protect/prevent strike from spikes. Connect varistor between input wires.

Note: For UL 294 / UL 1034 compliance the door strikes are to be powered via a UL 294/ UL 603 class 2 power limited output from a control panel and or power supply. Furthermore, when powered by AC/DC the units shall use a UL regulated UL 294/ UL 603 power limited class 2 output rated 12/24V with AC on indicator.

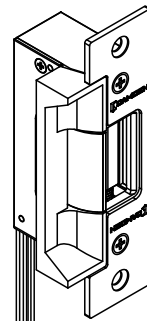

For Cut Wires

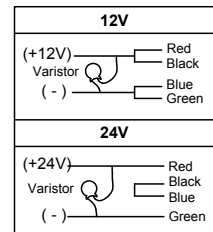

Or

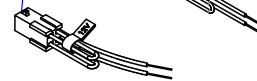

6. OPERATION

How to modify fail-safe to fail-secure or vice versa.

1. Loosen and remove the screws as per the product diagram below
2. Slide internal mechanism to the right
3. Tighten the screws.

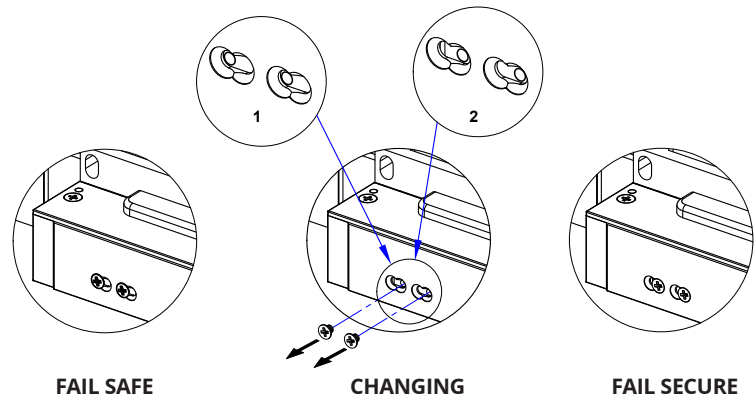

6. FACEPLATES

AVAILABLE FACEPLATES

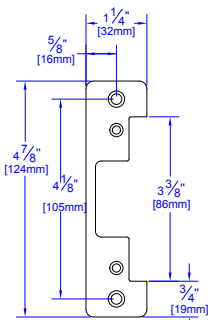

ESF2 - ANSI ROUND

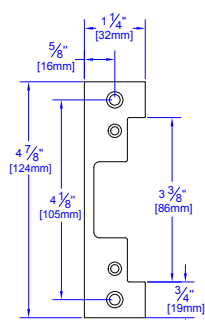

ESF1 - ANSI SQUARE

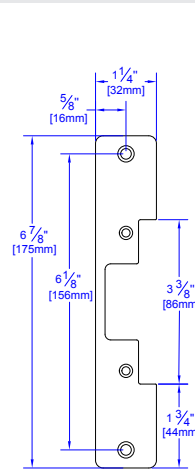

ESF3 - HOLLOW METAL DOOR

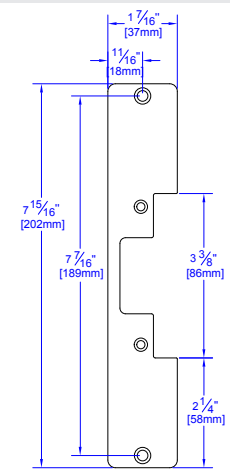

ESF4 - WOOD DOOR