

Notes:

1. This template is an addition to the device template. Locate centerlines using horizontal and vertical references on device template.
2. Do not scale drawing.
3. Dimensions are in inches (mm).
4. LHR door shown. Preparation is typical for both door hands.
5. For door reinforcement see template T30800.
6. Prepare mounting holes when installing trim.
7. Provide adequate internal support to prevent door deformation after trim is bolted to the device.

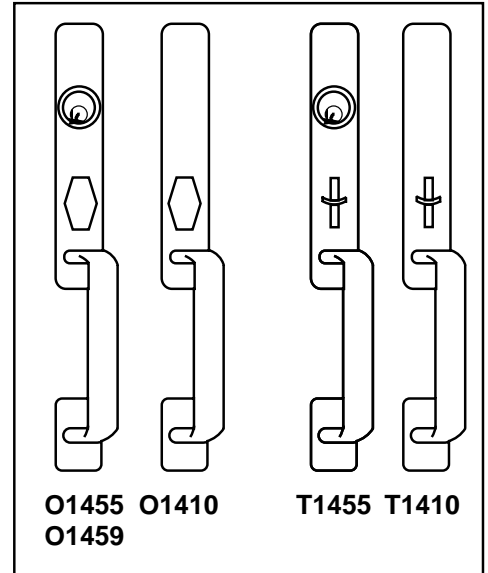

Hole	Specification
A	3/8(9.50) Dia. Outside Face 5/16(8) Dia. Inside Face (3 Places)
B	3/8(9.50) Dia. Outside Face

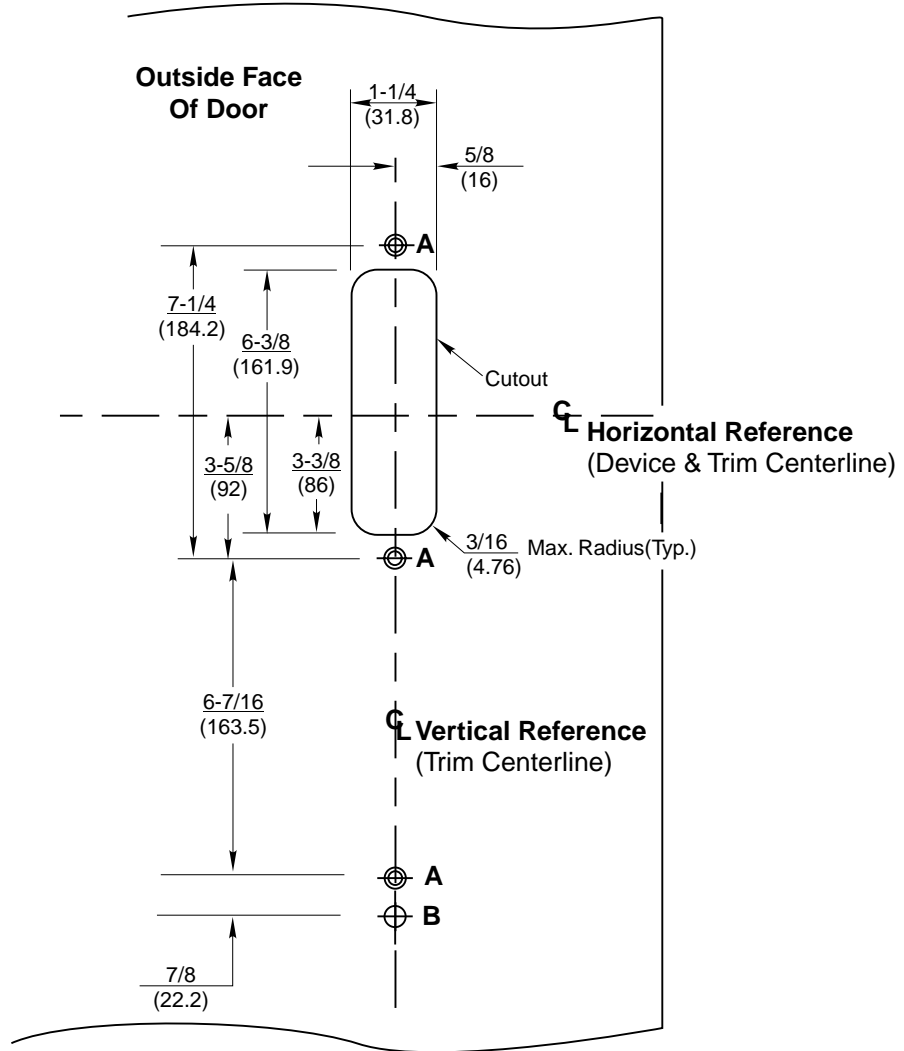

1410, 1455 & 1449 Series Narrow Escutcheon Trim
 With ED4200, ED4400, or ED4800 Series
 Rim and Vertical Rod Exit Devices
Metal Door Preparation



SUPERSEDES T30815 DO NOT SCALE DRAWING
 TEMPLATE NUMBER T30815-1 DATE 9-99