

# \*955 and \*959 SERIES HEAVY DUTY TRIM

For use with ED5000 Series Exit Device (Wood and Metal Doors)

FM 193 10/18

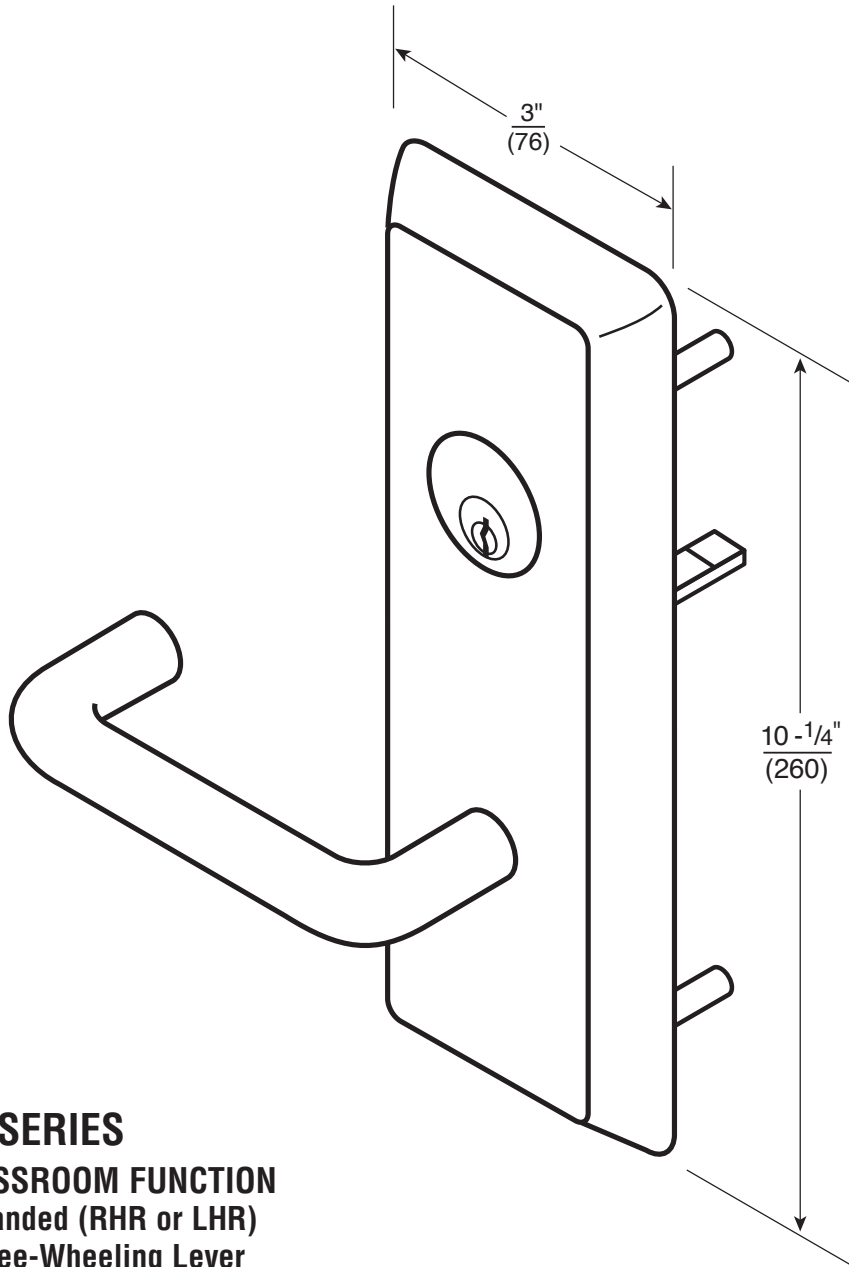

**\*955 SERIES**  
**CLASSROOM FUNCTION**  
Handed (RHR or LHR)  
Free-Wheeling Lever

**\*959 SERIES**  
**STOREROOM FUNCTION**  
Handed (RHR or LHR)  
Free-Wheeling Lever

**⚠ WARNING**  
This product can expose you to lead which is known to the state of California to cause cancer and birth defects or other reproductive harm. For more information go to [www.P65warnings.ca.gov](http://www.P65warnings.ca.gov).  
08/2018

\* Represents prefix letter(s) for various lever designs.

# Installation Instructions

1. Assemble trim. See previous page for components and instructions.
2. After marking door inside face for device location (Device Instructions), transfer "Vertical Reference Centerline" from inside to outside door face. Follow steps 2a. and 2b. below.

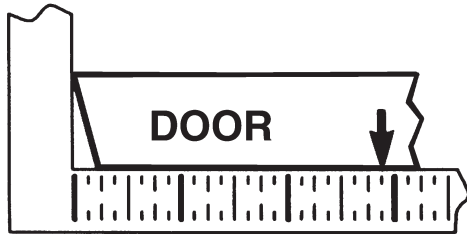

**2a. MEASURE INSIDE LINE LOCATION.**

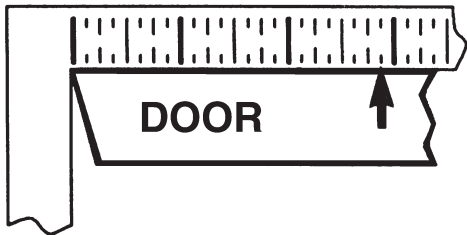

**2b. TRANSFER DIMENSION TO OUTSIDE FACE.**

3. Transfer "Horizontal Reference Centerline" from inside to outside door face.
4. Align trim template and tape to outside door face. **CAUTION:** Office copiers and facsimile machines may change the size of a drawing and make the template inaccurate to use as a door marker. If this is not the original template packed with the trim, use only the dimensions written on the template to locate the holes on the door (do not use the template as a door marker).
5. Spot holes and prepare door for trim.
6. Mount trim to door thru holes "B". Fasten, finger tight only, with 2 screws and washers seating on door, as shown in Figure 1.
7. With trim unlocked (tailpiece turning when lever is rotated), cut trim tailpiece as shown in Figure 2.
8. Seat device so that trim tailpiece penetrates cam slot, as shown in Figure 1. Continue as shown in device instructions.

**Figure 1**

Device is bolted to trim using holes "A" (closest to door lock edge).

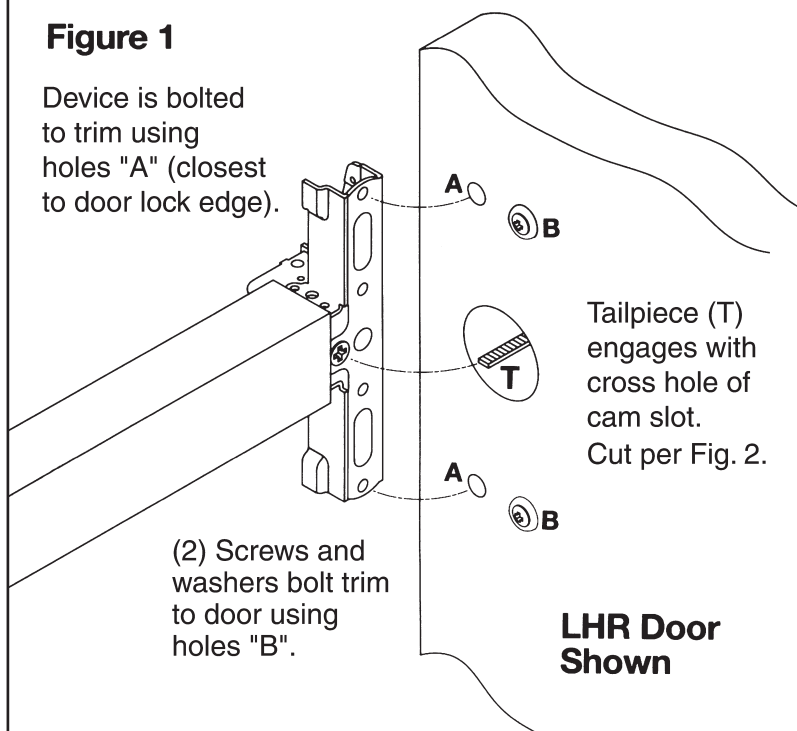

**Figure 2**

Trim must be unlocked (tailpiece fully extended).

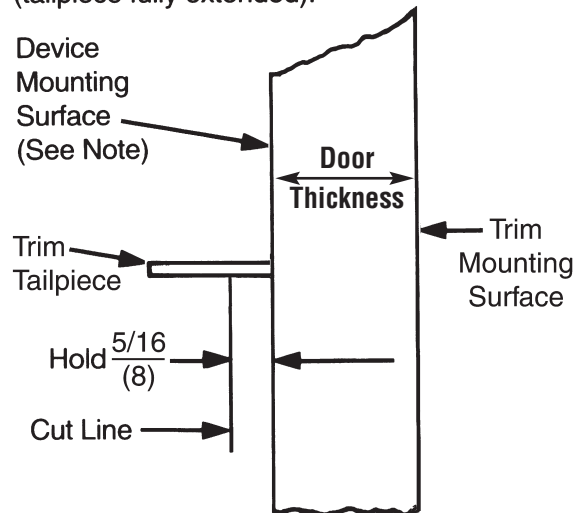

**NOTE:** Measure from device mounting surface (door face or shim surface).

# Trim Assembly Instructions

**1. Check cylinder components.**

**NOTE:** Cylinders longer than 1-1/8" (29) will require collars. Refer to Corbin Russwin cylinder collar chart.

**2. When required, cut cylinder tailpiece.**

Correct length is 1/16" to 3/16" (2 to 5) beyond cylinder housing cam.

**3. Assemble cylinder.**

Insert cylinder housing prongs into matching notches of escutcheon. Pass cylinder tailpiece thru cylinder collar (when required) and slot in cylinder housing cam. Fasten cylinder using (2) mounting screws. **DO NOT OVERTIGHTEN SCREWS.**

**4. Check cylinder action.**

Rotate cylinder tailpiece to cam the clutch lever down. This depresses the trim spindle assembly which disengages the trim spindle from the lever handle, putting the trim in a free-wheeling, locked mode.

**5. Determine trim function.**

- \*955 (Classroom) – Key locks/unlock lever handle
- \*959 (Storeroom) – Key locks/unlocks lever handle  
Key removable ONLY in locked position.

**6. To change trim function:**

Rotate cam tip to down position (locked mode). Move function screw as shown.

Corbin Russwin Cylinder Collar Chart	
Cylinder Length	Collar
1-1/8" (29)	None
1-1/4" (32)	654F07 **
1-1/2" (38)	654F08 **

\*\* Specify finish

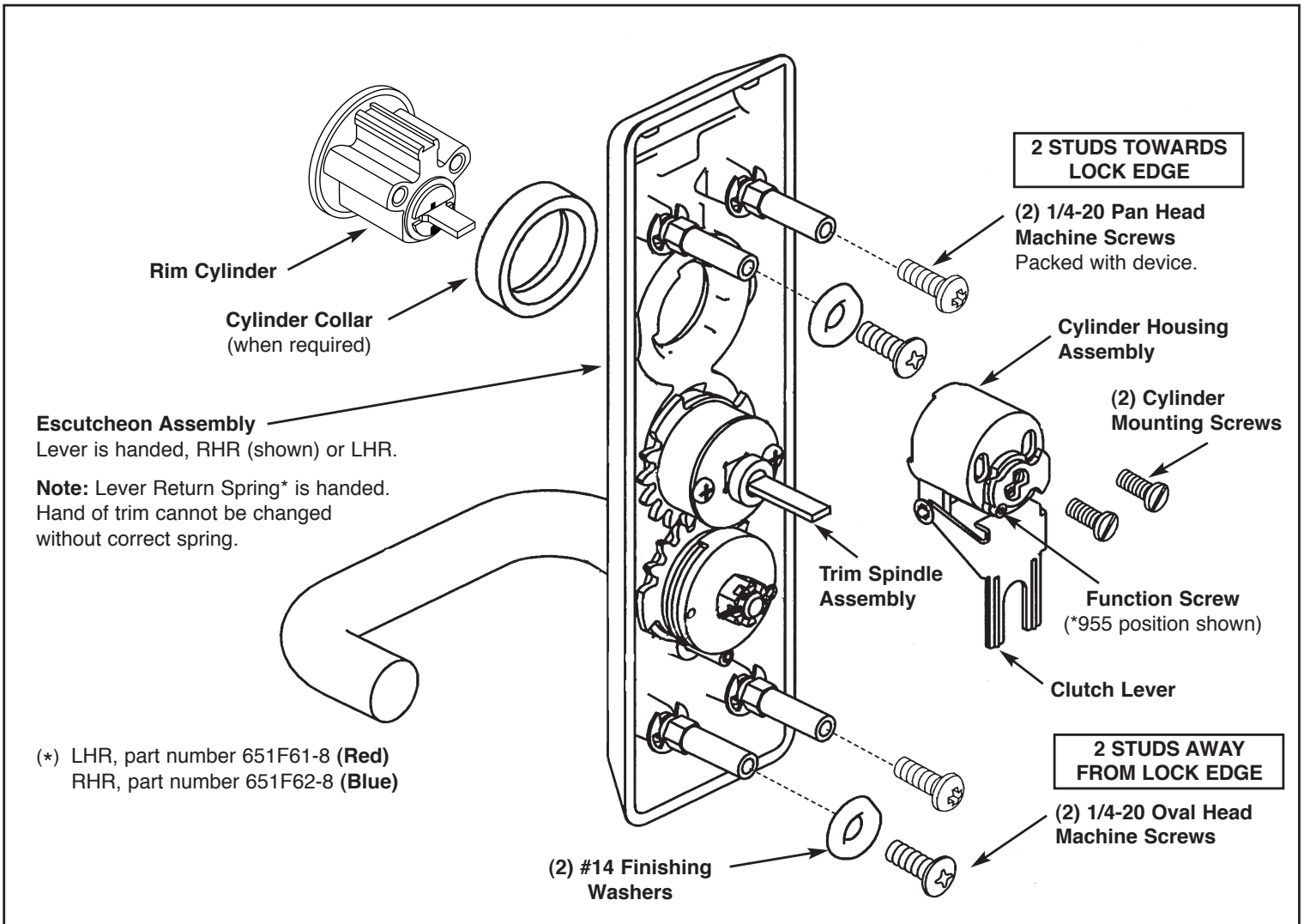
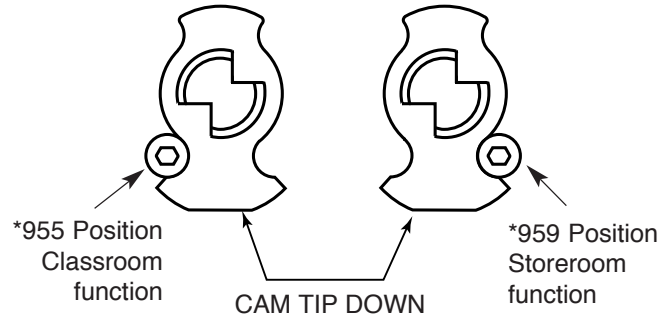

(\*) LHR, part number 651F61-8 (Red)  
RHR, part number 651F62-8 (Blue)

# Outside Door Face

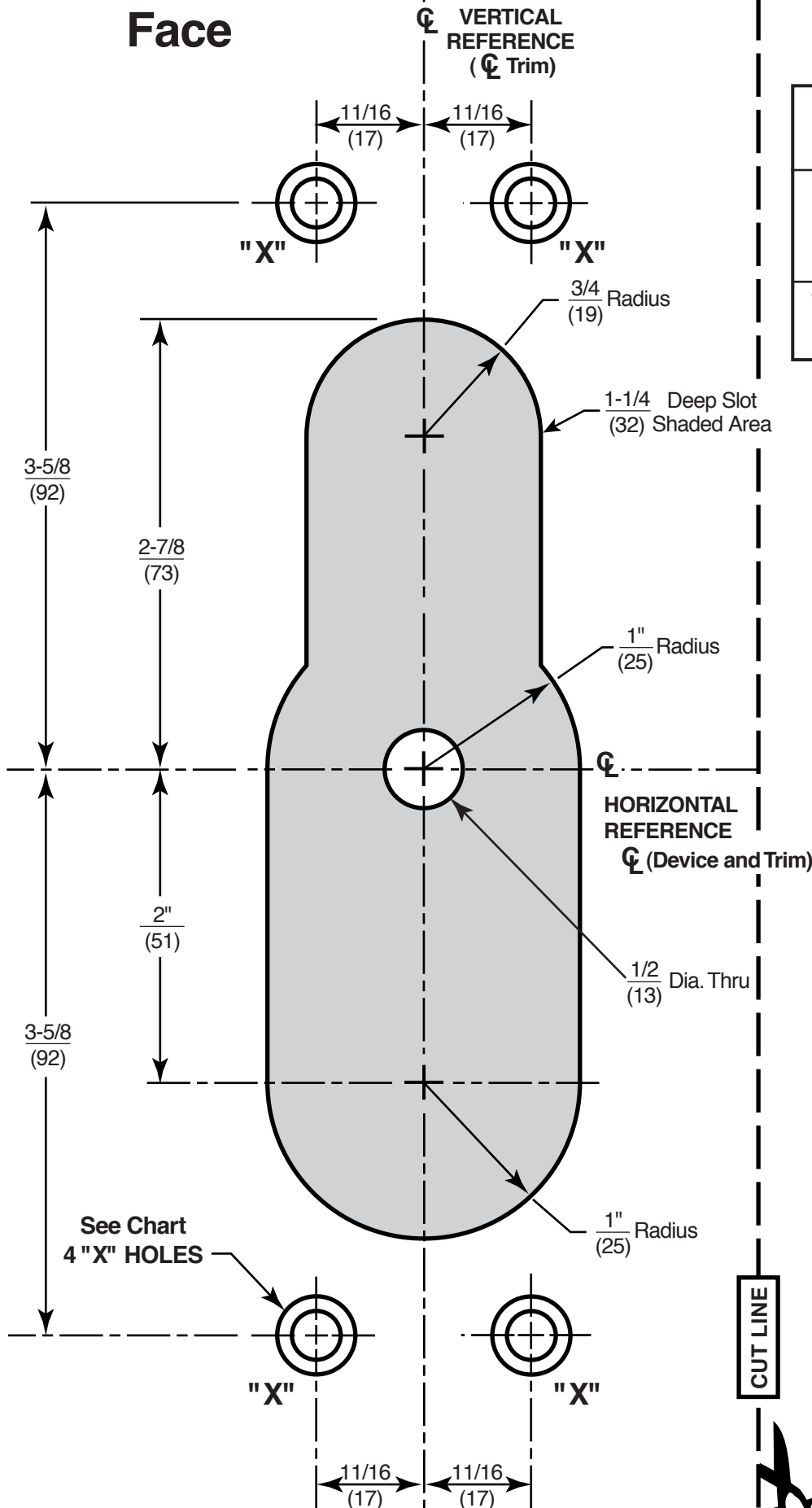

# Trim Template

<b>HOLES MARKED "X" (4 Places)</b>	
<b>METAL DOORS:</b>	
Inside Face	5/16" (8) Dia.
Outside Face	1/2" (13) Dia.
<b>WOOD DOORS:</b>	
	1/2" (13) Dia. Thru

Dimensions given in  $\frac{\text{Inches}}{\text{(mm)}}$



In U.S.:  
Corbin Russwin, Inc.  
225 Episcopal Road  
Berlin, CT 06037 USA  
Phone: 800-543-3658

Technical Product Support:  
Phone: 888-607-5703

In Canada:  
ASSA ABLOY Door Security Solutions Canada  
160 Four Valley Drive  
Vaughan, Ontario, Canada L4K 4T9  
Phone: 800-461-3007