

Access  
600™



**Installation Instructions  
For ED5200N Series Exit Devices  
With 9600 TCRNE1 Series Trim  
M802 125 kHz Reader Option  
(Includes: Rim and SecureBolt™)**

**Corbin  
Russwin**

**ASSA ABLOY**

FM294 10/18

**Attention Installer**

Please read these instructions carefully to prevent missing important steps.

Please Note: Improper installations may result in damage to the lock and void the factory warranty.

Important: The accuracy of the door preparation is critical for proper functioning and security of this lock.

Misalignment can cause premature wear and a lessening of security.

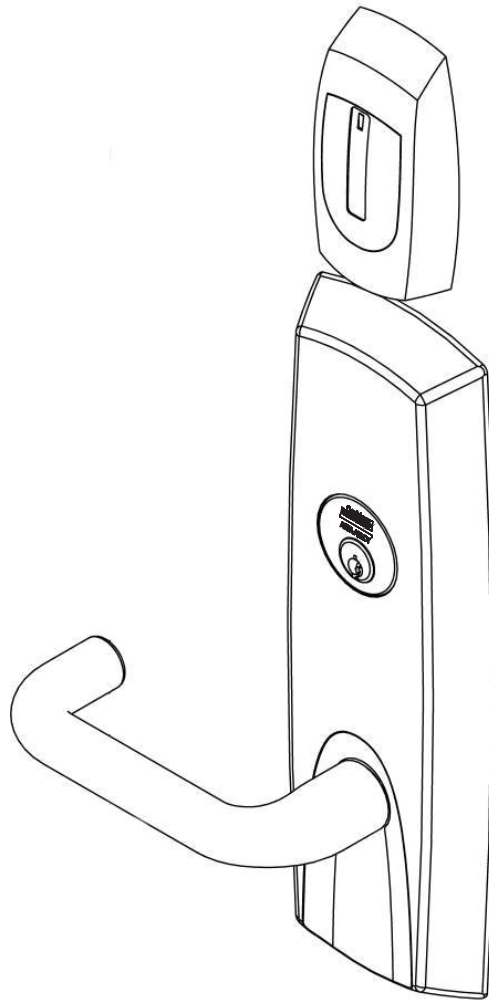

**WARNING**  
This product can expose you to lead which is known to the state of California to cause cancer and birth defects or other reproductive harm. For more information go to [www.P65warnings.ca.gov](http://www.P65warnings.ca.gov).  
08/2018

For Technical Assistance call Corbin Russwin at 1-800-810-WIRE (9473)



## Table of Contents

<b>1) Warning.....</b>	<b>3</b>
<b>2) General Description.....</b>	<b>4</b>
<b>3) Features .....</b>	<b>4</b>
<b>4) Regulatory Specifications .....</b>	<b>4</b>
<b>5) Wiring Diagrams.....</b>	<b>5</b>
<b>6) Product Illustration .....</b>	<b>7</b>
<b>7) Installation Instructions .....</b>	<b>8</b>
<b>8) Surface Vertical Rod Installation Instructions .....</b>	<b>14</b>
<b>9) Operational Check .....</b>	<b>16</b>

## 1) Warning

Warning: Changes or modifications to this unit not expressly approved by the party responsible for compliance could void the user's authority to operate the equipment.

This device complies with Part 15 of the FCC Rules. Operation is subject to the following two conditions: (1) this device may not cause harmful interference, and (2) this device must accept any interference received, including interference that may cause undesired operation.

Note: This equipment has been tested and found to comply with the limits for a Class B digital device, pursuant to Part 15 of the FCC Rules. These limits are designed to provide reasonable protection against harmful interference in a residential installation.

This equipment generates, uses and can radiate radio frequency energy and if not installed and used in accordance with the instructions, may cause harmful interference to radio communications. However, there is no guarantee that the interference will not occur in a particular installation. If this equipment does cause harmful interference to radio or television reception, which can be determined by turning the equipment off and on, the user is encouraged to try to correct the interference by one or more of the following measures:

- Reorient or relocate the receiving antenna
- Increase the separation between the equipment and receiver
- Connect the equipment into an outlet on a circuit different from that to which the receiver is connected
- Consult the dealer or an experienced technician for help

The term "IC:" before the radio certification number only signifies that Industry Canada technical specifications were met. This Class B digital apparatus meets all requirements of the Canadian Interference Causing Equipment Regulations. Operation is subject to the following two conditions: (1) this device may not cause harmful interference, and (2) this device must accept any interference received, including interference that may cause undesired operation.

Cet appareillage numérique de la classe B répond à toutes les exigences de l'interférence canadienne causant des règlements d'équipement. L'opération est sujette aux deux conditions suivantes: (1) ce dispositif peut ne pas causer l'interférence nocive, et (2) ce dispositif doit accepter n'importe quelle interférence reçue, y compris l'interférence qui peut causer l'opération peu désirée.



To avoid possible damage from electrostatic discharge (ESD), some basic precautions should be used when handling electronic components:

- Minimize build-up of static by touching and/or maintaining contact with unpainted metal surfaces such as door hinges, latches, and mounting plates especially when mounting electronic components such as readers and controllers onto the door.
- Leave components (reader and controller) protected in their respective anti-static bags until ready for installation
- Do not touch pins, leads or solder connections on the circuit boards

\*Any retrofit or other field modification to a fire rated opening can potentially impact the fire rating of the opening, and Corbin Russwin, Inc. makes no representations or warranties concerning what such impact may be in any specific situation. When retrofitting any portion of an existing fire rated opening, or specifying and installing a new fire-rated opening, please consult with a code specialist or local code official (Authority Having Jurisdiction) to ensure compliance with all applicable codes and ratings.



## 2) General Description

The Corbin Russwin Access 600 TCRNE1 Series exit device is designed to interface with existing Wiegand Electrical Access Control (EAC) panels. The reader requires 12VDC for power and is available with 125 kHz HID proximity technology. The Access 600 technology is designed around Corbin Russwin's Grade 1 hardware. The exit device comes with touch bar monitoring (REX) and is provided with an external Door Position Switch (DPS). The exit device trim is operated by a 24VDC solenoid and is offered in fail safe and fail secure versions. Weather seal gaskets are also included for outdoor applications. The Access 600 reader provides visual (LED) and audible indication of lock state (locked/unlocked).

## 3) Features

- Door Thickness: 1-3/4" Standard; Can be furnished for other door thicknesses upon request. Consult factory.
- Outside lever controlled by reader or key allows lever to retract latch
- Inside push bar produces REX (request to exit) signal and retracts latch
- Fail safe or fail secure operation (must specify)
- Wire from EAC panel to door must be shielded with a drain terminated at EAC panel controller
- Wires directly to EAC panels
- Accepts all HID 125 kHz bit formats
- McKinney QC12 Hinge with ElectroLynx® plug and play

## 4) Regulatory Specifications

- Reader Draw = 150mA @12VDC / 24VDC
- Actuator Draw = 400mA inrush / 15mA continuous @12VDC / 24VDC
- Total System Draw = 550mA @12VDC / 24VDC

- **UL 294 Access Control Performance Ratings:**

Destructive Attack	Level I
Line Security	Level I
Endurance	Level IV
Standby Power	Level I

- UL294 6th Edition (Access Control System Units)
- This product meets the requirements of CAN/ULC-S319-05 Equipment Class I
- ANSI/BHMA A156.25 Listed Grade 1 Compliant

Wiring methods shall be in accordance with the National Electrical Code (ANSI/NFPA70), CSA 22.1, Canadian Electrical Code (CEC), Part I, Safety Standard for Electrical Installations, local codes, and the authorities having jurisdiction.

## 5) Wiring Diagrams

Product	8 PIN CONNECTOR								4 PIN CONNECTOR			
	1-Black	2-Red	3-White	4-Green	5-Orange	6-Blue	7-Brown	8-Yellow	1-Violet	2-Gray	3-Pink	4-Tan
ACCESS CONTROL DEVICES: Access 600 Mortise, ElectroLynx wire Color / Function assignments												
Corbin Russwin Mortise Lock	12/24VDC (Reader)		WIE-GAND	WIE-GAND	RX	RX	EGND	LED	12/24 VDC (LOCK RELAY)		DPS (NC)	DPS (COM)
	NEG	POS	DATA_1	DATA_0	NO	COM	REF. *DIA-GRAMS	REF. *DIA-GRAMS	NEG	POS	DPS	DPS
Cylindrical/Exits	NEG	POS	DATA_1	DATA_0	NO	COM			NEG	POS	-	-

\*Diagram on following page

### Reader LED Configuration

The Harmony Series reader can be configured for (3) modes of LED operation. Call 1-800-810-WIRE for details.

#### Mode 1:

- Red LED 'ON' when powered.
- Presenting a valid credential causes LED to 'FLICKER' green and return to red state.

#### Mode 2:

- Green LED "ON" when powered.
- No Flicker after presenting valid valid credential.

Note: LED wire must be connected to circuit GROUND of the system's power supply.

#### Mode 3:

- EAC Panel controls LED operation.

Note: Control of LED is a function of the EAC panel equipment (i.e. relay) to toggle between green and red.

Note: When LED wire is tied directly into EAC panel relay, no AC signals should be applied on wire or door reader performance will be impacted.

Wire from EAC panel to door must be shielded with drain terminated at EAC panel controller

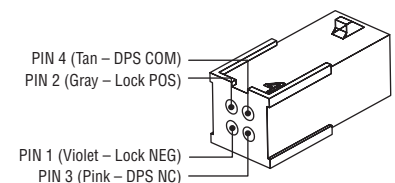
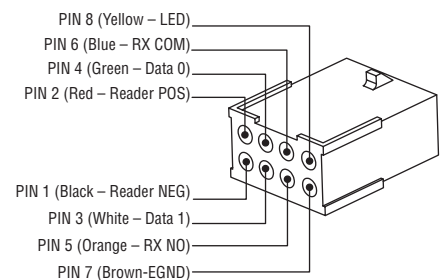

### Wire Gauge Charts

Total One-Way Length of Wire Run (ft)	Load Current @ 12VDC							
	1/4A	1/2A	3/4A	1A	1-1/4A	1-1/2A	2A	3A
100	20	18	16	14	14	12	12	10
150	18	16	14	12	12	12	10	—
200	16	14	12	12	10	10	—	—
250	16	14	12	10	10	10	—	—
300	16	12	12	10	10	—	—	—
400	14	12	10	—	—	—	—	—
500	14	10	10	—	—	—	—	—
750	12	10	—	—	—	—	—	—
1,000	10	—	—	—	—	—	—	—
1,500	10	—	—	—	—	—	—	—

Total One-Way Length of Wire Run (ft)	Load Current @ 24VDC							
	1/4A	1/2A	3/4A	1A	1-1/4A	1-1/2A	2A	3A
100	24	20	18	18	16	16	14	12
150	22	18	16	16	14	14	12	10
200	20	18	16	14	14	12	12	10
250	18	16	14	14	12	12	12	10
300	18	16	14	12	12	12	10	—
400	18	14	12	12	10	10	—	—
500	16	14	12	10	10	—	—	—
750	14	12	10	10	—	—	—	—
1,000	14	10	10	—	—	—	—	—
1,500	12	10	—	—	—	—	—	—

## 5) Wiring Diagrams (Continued)

### Typical ED5000N (S)(A) M802 Series Lock Application Diagram (24VDC Lock)

MODE 1: LED WIRE NOT USED = RED LED 'ON' WHEN POWERED

Standard Application Shown - For Alternative Applications Contact 1-800-810-WIRE (9473)

Reader Electronics Require 12 or 24VDC UL294 Listed, Power Limited Power Supply (or UL603)



\*IMPORTANT: Pin 7 must be tied to earth ground in the access control panel.

Failure to follow proper ESD safe grounding procedures could lead to equipment failure.

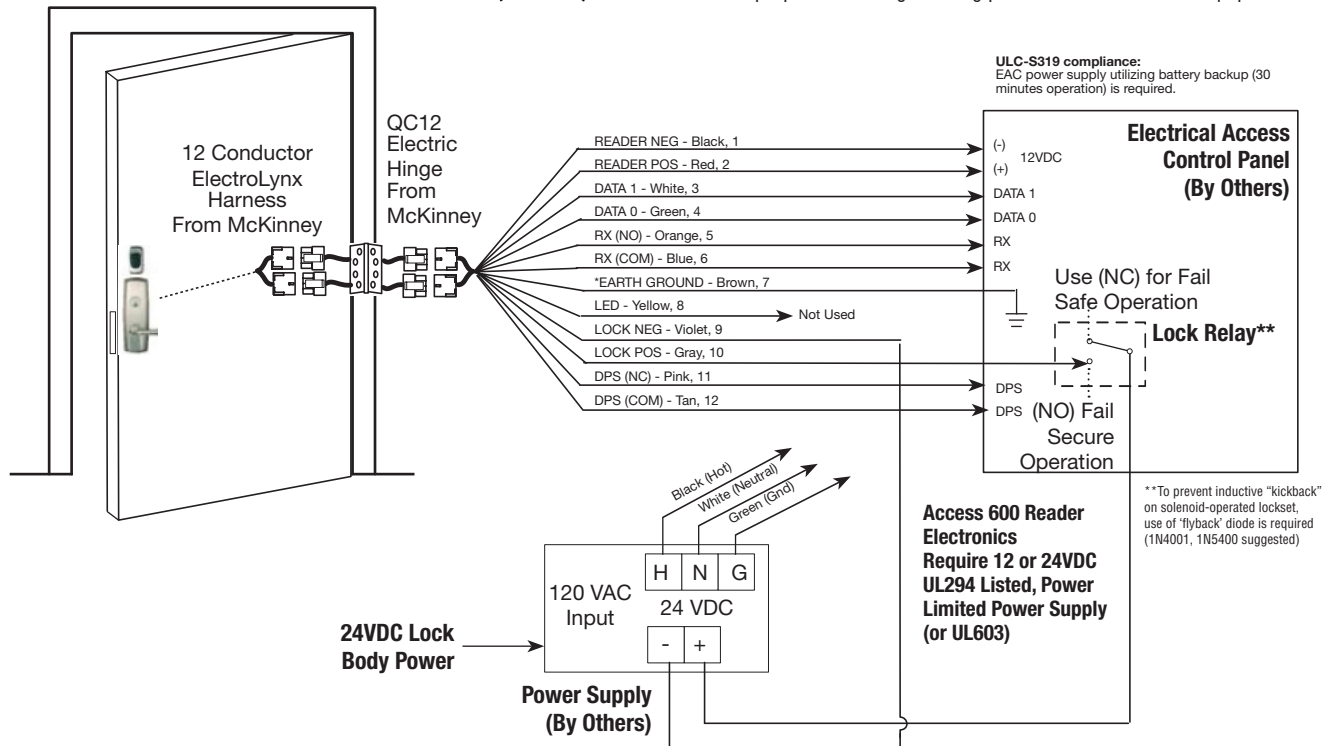

## 6) Product Illustration

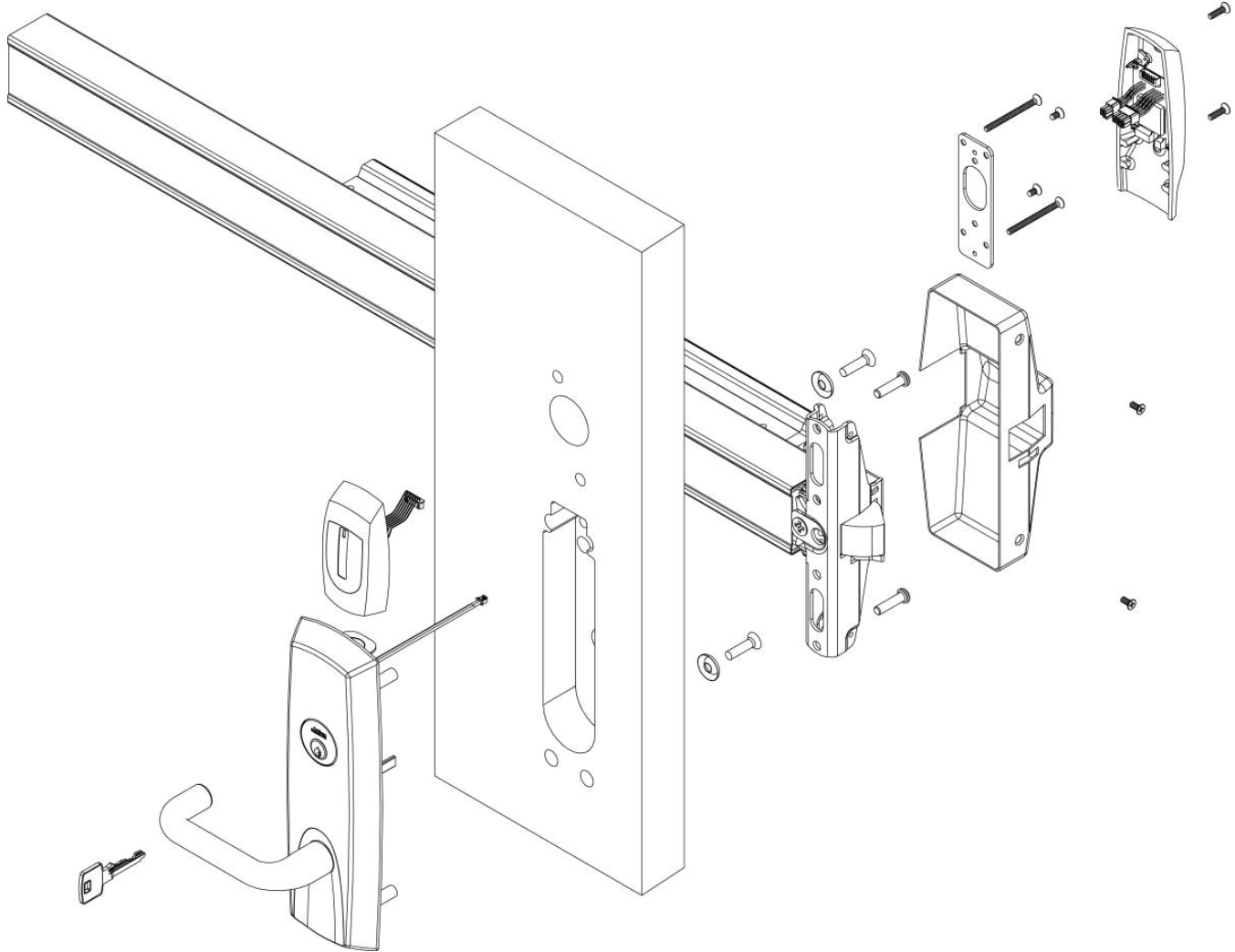

Item	Part Number	Description	Req.
1	752F652 FIN	Esc SA, M802 - Exits Rim/ CVR Functions (*9603, *9605)	1
	752F662 FIN	Esc SA, M802 - Exits SVR (LHR) Functions (*9S603, *9S605)	
	752F672 FIN	Esc SA, M802 - Exits SVR (RHR) Functions (*9S603, *9S605)	
2	Exit Trim	Refer to Access 600 Catalog to Configure Trim Order String	1
		Refer to Access 600 Catalog to Configure Rail Order String	

### Tools Required

- Phillips screw driver (standard size)
- Flat blade screw driver (standard)

## 7) Installation Instructions

### 1. Verify Hand and Bevel of door.

Door should be fitted and hung.

Verify box label for size of exit device, function and hand.

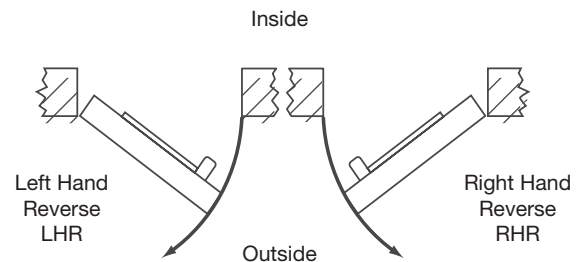

Fig. 1

### 2. Trim Assembly Instructions:

#### a. Check cylinder components:

Cylinders longer than 1-1/8" (29mm) require collars.

Refer to Cylinder Collar Chart (Fig. 2a).

#### b. If required, modify by cutting cylinder tailpiece:

Correct length is 1/16" to 3/16" (2 to 5mm) beyond cylinder housing cam.

#### c. Assemble cylinder:

1. Insert cylinder housing prongs into matching notches of escutcheon.

2. Pass cylinder tailpiece through cylinder collar (if required) and slot in cylinder cam.

3. Fasten cylinder in escutcheon recess or collar using 2 mounting screws.

**Do not overtighten screws.**

#### d. \*\*Escutcheon Assembly (Fig. 2b):

The lever is handed (LHR shown).

Note: Lever Return Spring is handed. Hand cannot be changed without correct spring. Lever Return Spring handing can be identified by the color of the spring:

- LHR: Part Number 651F618 (Red)
- RHR: Part Number 651F628 (Blue)

Cylinder Collar Chart		
Cylinder Length		Collar
Inches	Millimeters	
1-1/8"	29mm	None
1-1/4"	32mm	422F88*
1-1/2"	38mm	686F98*

\*Specify Finish

Fig. 2a

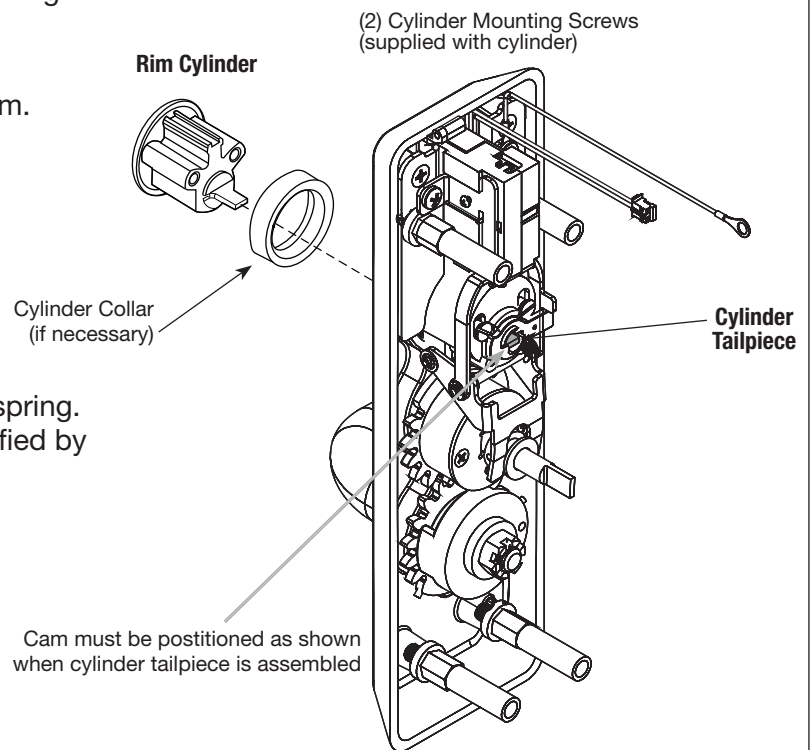

Fig. 2b



## 7) Installation Instructions (Continued)

### 3. Install Outside Trim

- a. Make sure tailpiece is oriented vertically.
- b. Feed trim wire harness through wire harness hole (Fig. 3a).
- c. Mount trim assembly to door pulling slack wire towards device side of door.

Note: Be careful not to pinch wire harness.

- d. When mounting trim, lift tailpiece to pass through hole on device side.

Note: Make sure tailpiece is still oriented vertically.

- e. Fasten trim assembly to door using (2) 1/4-20 oval head screws and (2) finish washers (Fig. 3b).

Note: Finger tighten only.

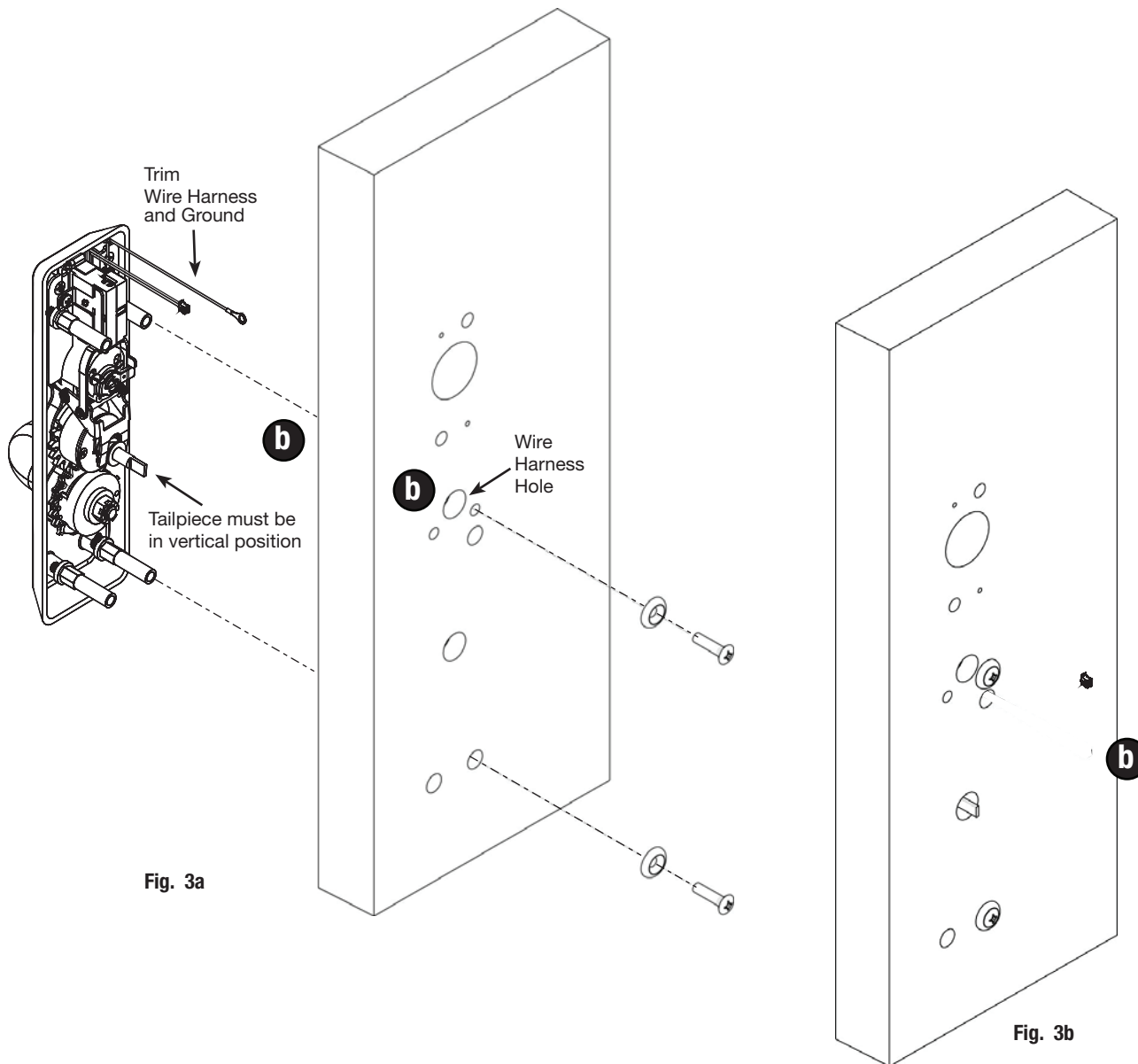
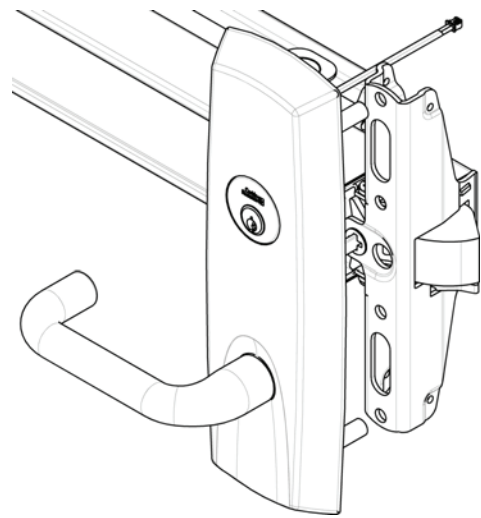
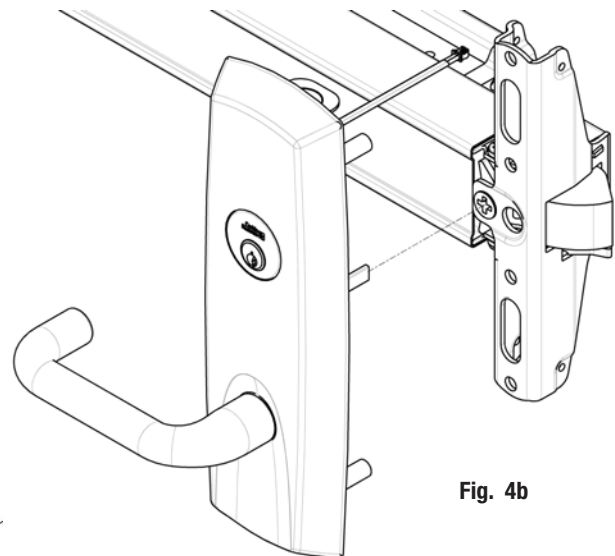
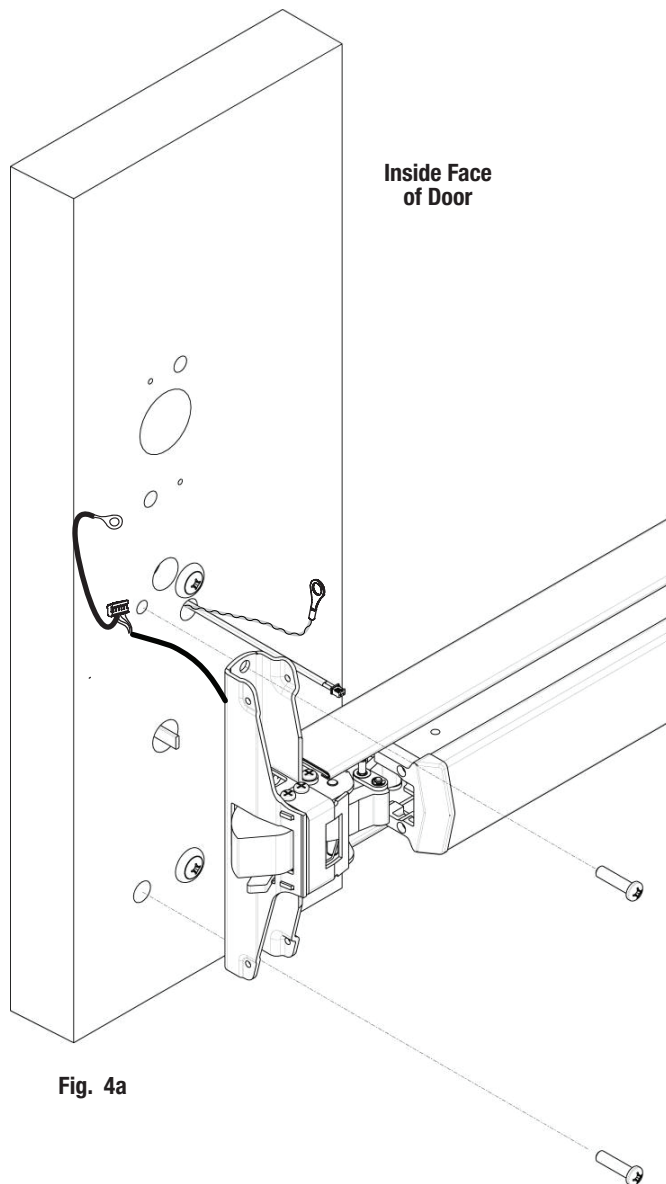

Fig. 3a

Fig. 3b

## 7) Installation Instructions (Continued)

4. Install Exit Device:
  - a. Seat device against door being careful to align vertical trim tailpiece to engage with cross hole of device cam.
  - b. Fasten device to trim assembly using (2) 1/4-20 pan head screws.
  - c. Follow instructions packed with device to secure device to door.
  - d. Tighten all 4 screws.



## 7) Installation Instructions (Continued)

### 5. Install Head Cover:

- a. Lay wire harnesses (trim harness and device harness) across  $\frac{3}{4}$ " hole (Fig. 5a).
- b. Tuck wires into hole when installing cover so that wires are not pinched between head cover and door.
- c. Attach head cover using (2) #8-32 flat head screws (Fig. 5b).

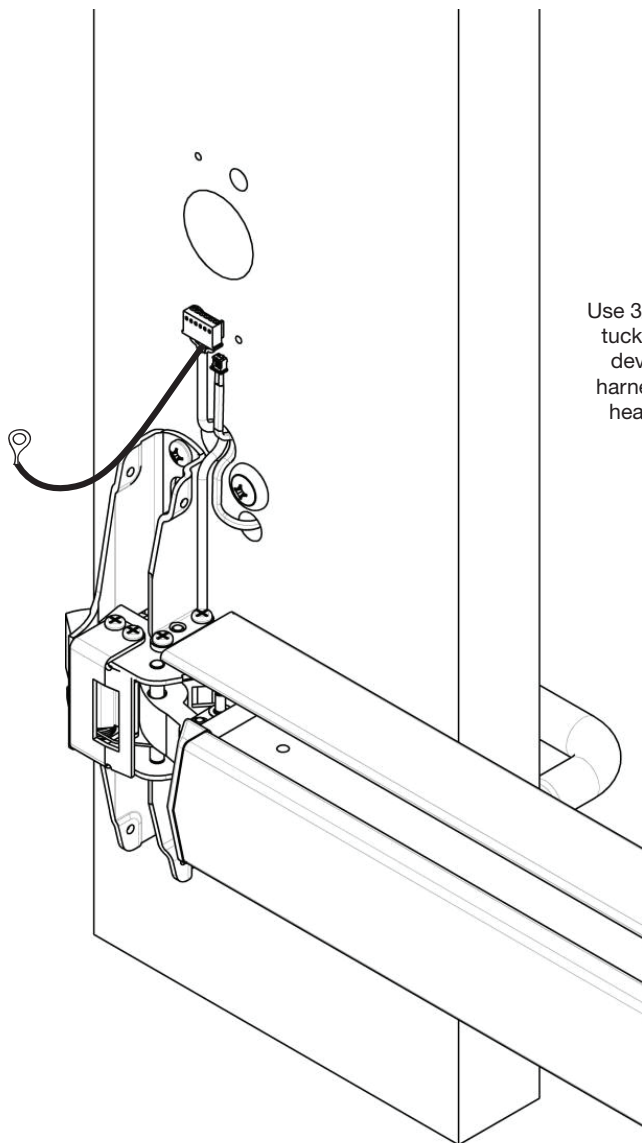

Fig. 5a

Use  $\frac{3}{4}$ " hole to tuck trim and device wire harness under head cover,

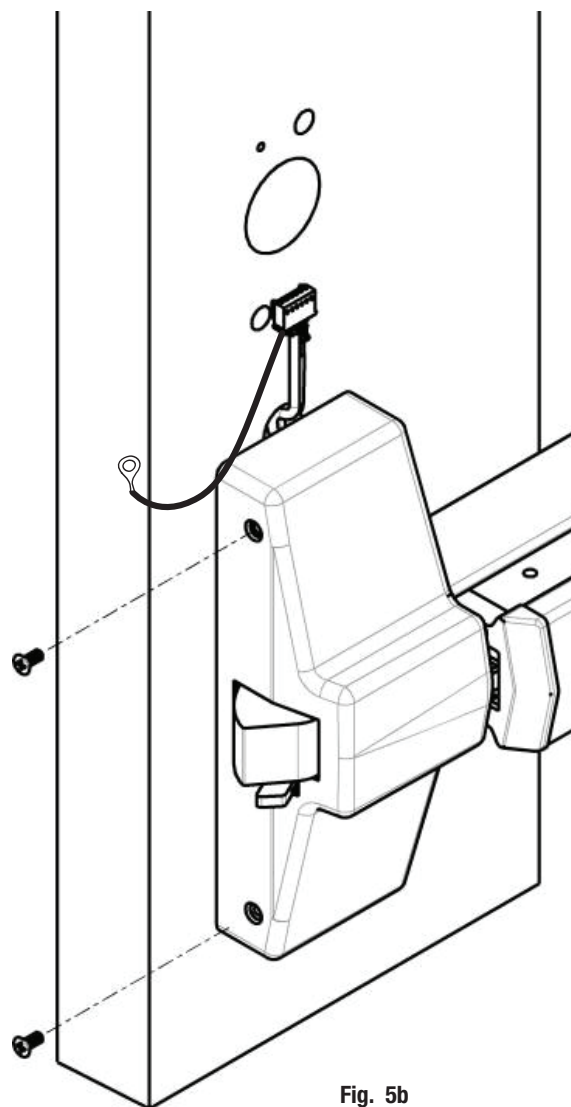

Fig. 5b

## 7) Installation Instructions (Continued)

### 6. Install Outside Reader and Inside Mounting Plate.

**If this installation involves a surface vertical rod, go to the Surface Vertical Rod section on page 12.**

- Feed Reader wire harness through door and through hole in mounting plate (Fig. 6a).
- Insert two #8 x 1-3/4" flat head through mounting plate and into escutcheon (Fig. 6a and 6b).
- Connect pin 5 green/yellow ground wire ring terminal to top right screw (Fig. 6b and 6c).

Note: Be careful not to pinch wires under mounting plate.

- Check that Reader is straight on door then tighten screws.
- Drill two 1/8" diameter holes and install (2) #8 x 3/4" combination screws through plate and into face of door.

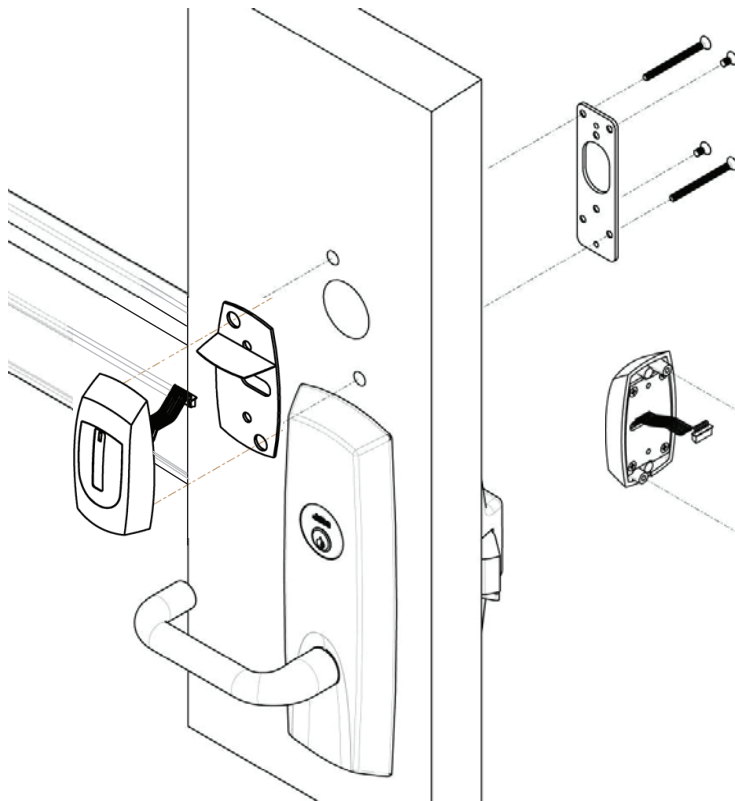

Fig. 6a

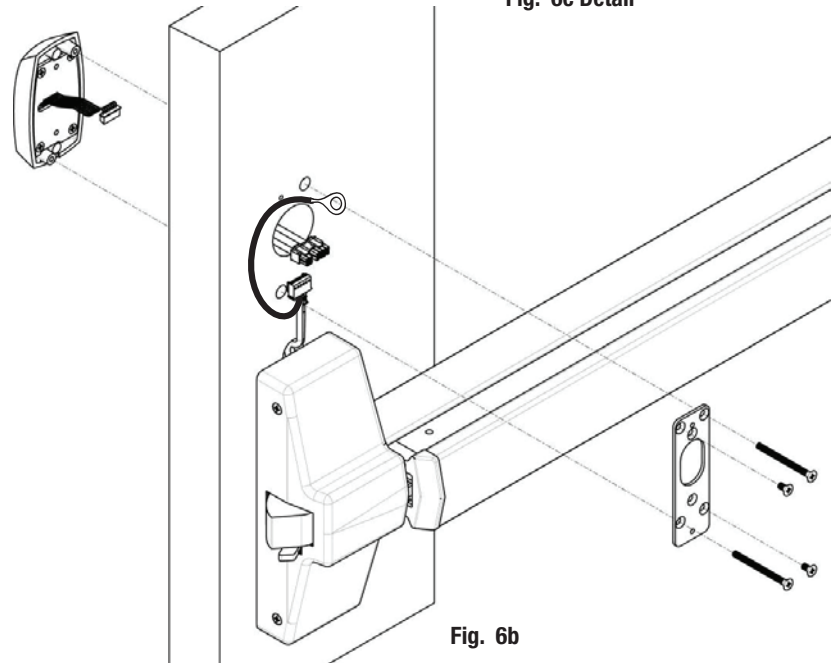

Fig. 6b

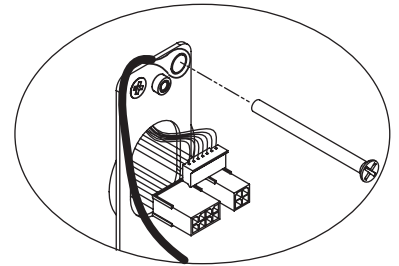

Fig. 6c Detail

## 7) Installation Instructions (Continued)

7. Install Inside Escutcheon:
  - a. Make electrical connections (Step 8).
  - b. Feed excess ElectroLynx® wire harness back into door.
  - c. Feed excess trim and exit device under head cover.
  - d. Install inside escutcheon using (2) #8-32 x 5/8" oval head screws.

Note: Be careful not to pinch wires between escutcheon and door surface.

Notes:

- Insert the ElectroLynx 8- and 4-pin connectors and establish their position inside the door prep.
- Neatly fold the wires onto themselves and into the remaining space to prevent pinching wires when mounting escutcheon.

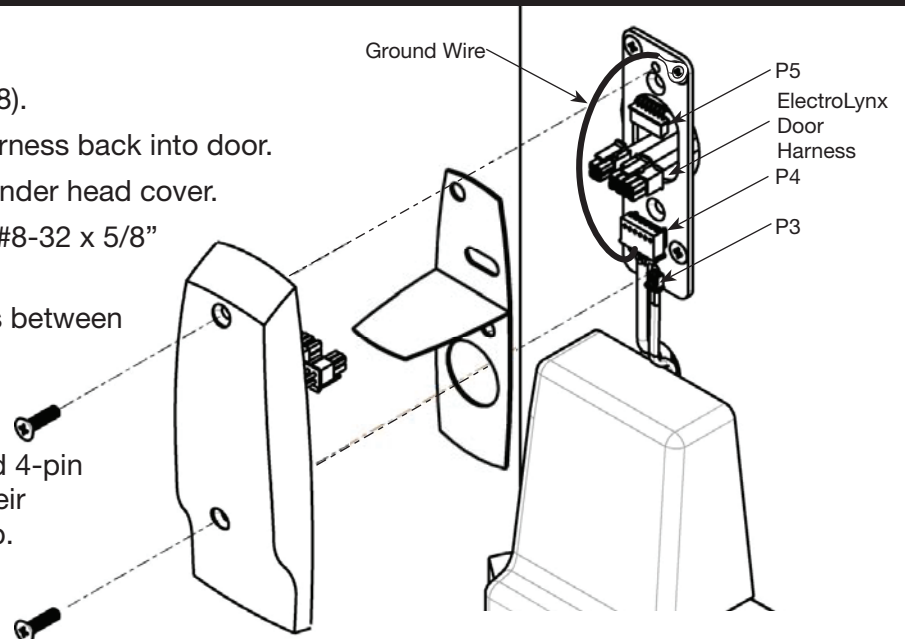

Fig. 7

8. Attach Connectors (Interior PCB Assembly):
  - a. Connect P3 (2 Pin Connector) from trim to J3 on interior PCB assembly (Fig 8).
  - b. Connect P4 (6 Pin Connector) from exit device to J4 on interior PCB assembly.
  - c. Connect P5 (7 Pin Connector) from Reader PCB to J5 on interior PCB assembly.
  - d. Connect ElectroLynx®Harness (4 Pin & 8 Pin) from door harness to ElectroLynx harness on Interior PCB Assembly.
  - e. Place extra wire inside door hole.

Note: Connectors go on only one way.

Do not offset connector and be sure they are completely seated.

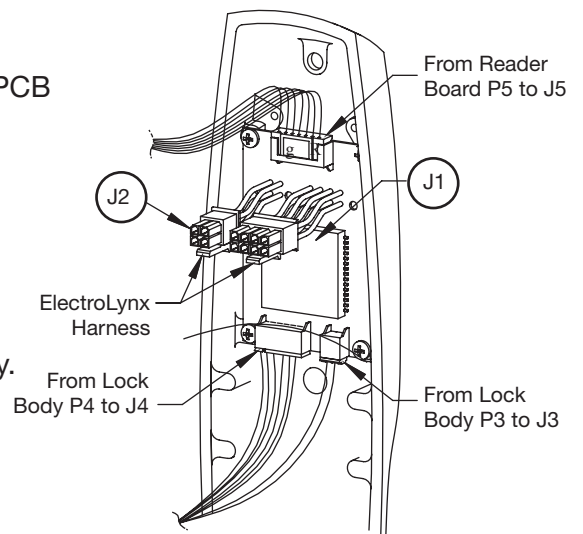

Fig. 8

### PCB Layout - Wire Assignments - ElectroLynx Assembly (Molex)

J2		J1			
1-Violet Lock Neg (Solenoid, neg)	3-Pink -	1- Black PWR NEG	3-White DATA 1	5-Orange RX (NO)	7-Brown EGND
2-Gray Lock Pos (Solenoid, pos)	4-Tan -	2-Red PWR POS	4-Green DATA 0	6-Blue RX (COM)	8-Yellow LED

## 8) Surface Vertical Rod Installation Instructions

1. Install Inside Mounting Bracket with Outside Escutcheon.

**If this is a Surface Vertical Rod installation, follow the installation instructions on pages 4 - 8 before continuing:**

- a. Position outside escutcheon against door (Fig. 4A).

Note: Insert gasket, if necessary.

- b. Route antenna cable through door.
- c. Route wires along the outside (not through) the mounting bracket (Fig. 4B).
- d. Secure with mounting bracket screws.

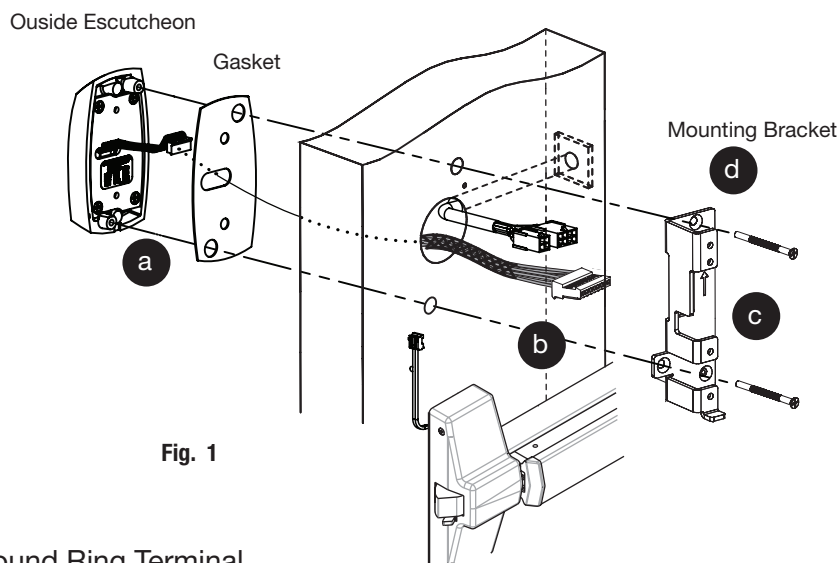

2. Attach Ground Ring Terminal  
Attach ground ring terminal to screw on bracket.

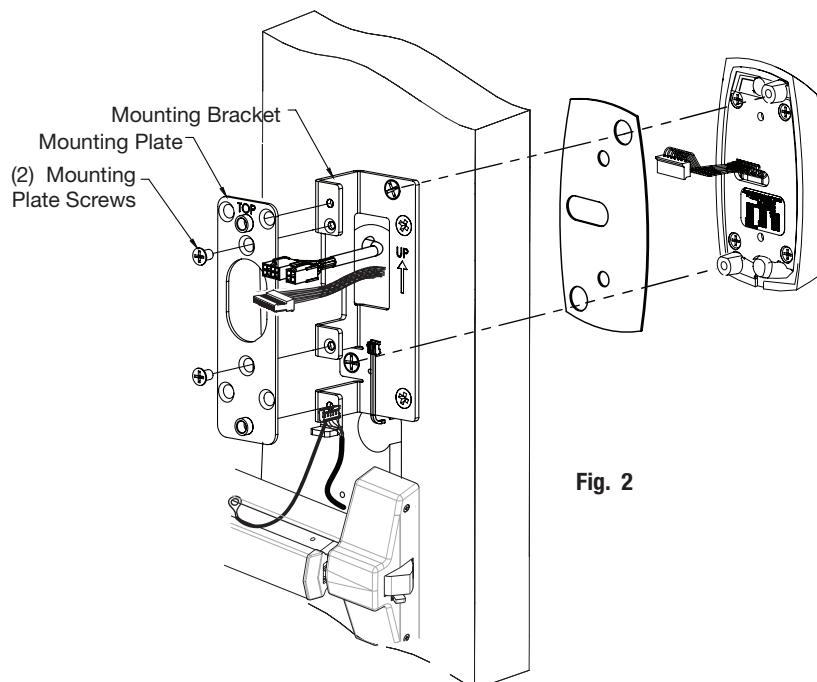



## 8) Surface Vertical Rod Installation Instructions (Continued)

3. Attach Connectors (Interior PCB Assembly)
  - a. Connect P5 (7-pin connector) from Reader board to J5 on interior PCB assembly (Fig 3a and 3b).
  - b. Connect ElectroLynx harness (4 and 8-pin) from door harness to ElectroLynx harness on interior PCB assembly (Fig 3a and 3b).
  - c. Connect P3 (2-pin connector) from lockbody to J3 and P4 (6-pin connector) from lockbody to J4 on interior PCB assembly (Fig 3a and 3b).

**NOTES:**

Neatly fold the wires onto themselves and into the remaining space along side the mounting bracket to prevent pinching wires when mounting escutcheon.

Connectors go on only one way.

Do not offset connector and be sure they are completely seated.

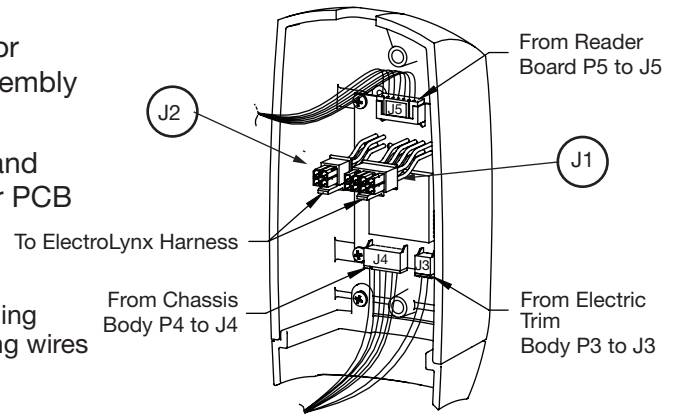

**Fig. 3a**

PCB Layout - Wire Assignments - ElectroLynx Assembly (Molex)					
J2		J1			
1-Violet Lock DC Neg (Solenoid, neg)	3 - Pink NOT USED	1- Black PWR GND	3-White Wiegand DATA 1	5-Orange RX (N/O)	7-Brown EGND
2-Gray, Lock DC Pos (Solenoid, pos)	4-Tan NOT USED	2-Red PWR 12VDC	4-Green Wiegand DATA 0	6-Blue RX (COM)	8-Yellow LED

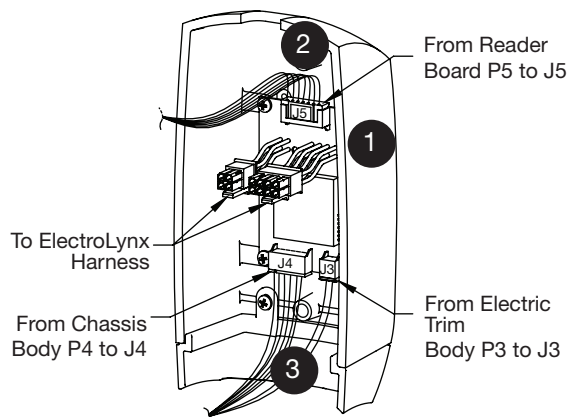
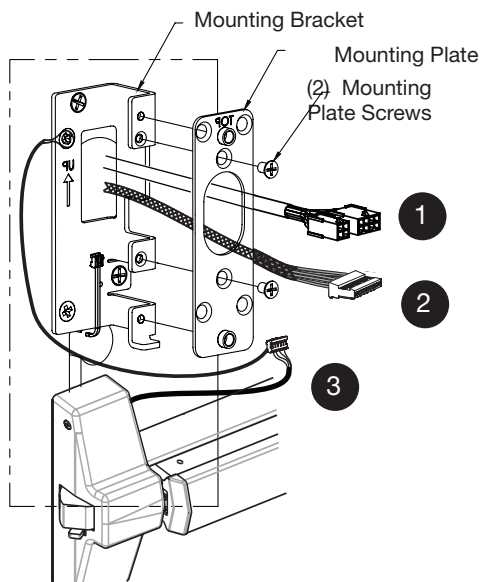

**Fig. 3b**

## 8) Surface Vertical Rod Installation Instructions (Continued)

4. Install Inside Escutcheon
  - a. Position inside gasket and escutcheon against door. Verify that no wires are being pinched.
  - b. Mount inside escutcheon assembly to plate using (2) #8-32 x 5/8" Phillips flat head undercut machine screws.

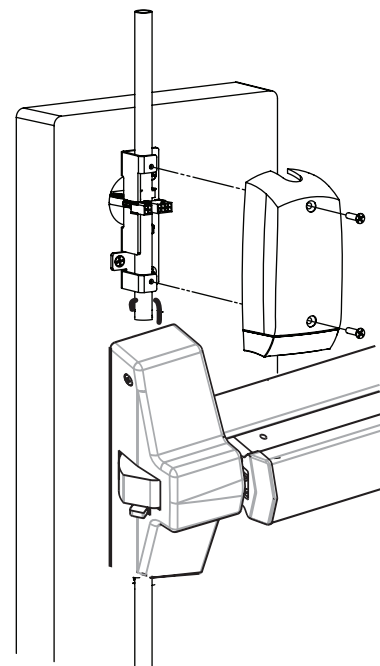

Fig. 4

## 9) Operational Check

Before closing door test for cylinder function of lock cylinder and Inside lever:

- a. Insert key into cylinder and rotate.
- b. The key will retract the latch. Key should rotate freely.
- c. Inside lever retracts latch.
- d. Close door, ensure latch fully extends into strike and does not bind.

Note: Fail safe trim cylinder will have to be tested after wiring is complete and power is turned on.

Note: Once electrical wiring has been successfully completed according to proper application, follow the following step:

- a. Turn power ON at EAC panel.
- b. Verify LED located on reader is ON (Red or Green depending on reader configuration (See reader LED Configuration)).
- c. Present proximity credential and verify LED and sounder activity.
- d. Verify valid card read at EAC Panel.
- e. Verify system operation functions; i.e., when prox credential is presented to reader that the door unlocks.





## 9) Operational Check (Continued)

### Wiegand Test Unit

The ASSA ABLOY Wiegand Test Unit verifies your installation in the field. The test unit checks for proper wiring, card reader data integrity, lock functionality including lock/unlock, door position status, and request-to-exit (REX) status.

In addition, this tool provides product demonstration abilities to highlight the product's features and capabilities.

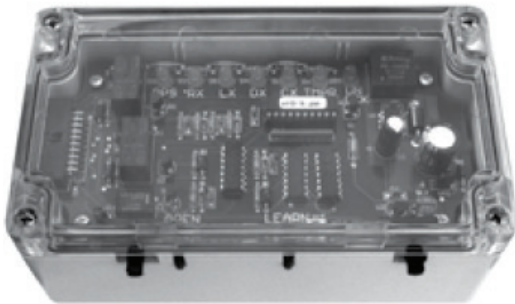

Feature	WT1	WT2
12 or 24VDC solenoid lock voltage adjustable	X	X
Operates as Fail Safe or Fail Secure	X	X
"Learn" mode allows testing of specific cards without programming at the panel level	X	X
Card reader data integrity is validated at test unit	X	X
Works with SE LP10	X	X
Displays detailed Wiegand data, including hexadecimal string and total bits received		X
Displays measured end-of-line resistor values (if applicable)		X





Corbin Russwin  
225 Episcopal Road  
Berlin, CT 06037  
Phone: 800-543-3658  
Fax: 800-447-6714  
corbinrusswin.com

ASSA ABLOY is the global  
leader in door opening solutions,  
dedicated to satisfying  
end-user needs for security,  
safety and convenience