

CL33900 Electrified Series ElectroLynx Connector System

For ASSA ABLOY Group Doors and Hinges with ElectroLynx Connector System

FOR INSTALLATION ASSISTANCE, CALL CORBIN RUSSWIN AT
1-800-543-3658 • www.corbinrusswin.com



ASSA ABLOY

- Plug 8-Pin Lock connector into 8-Pin Door connector (4-Pin Door connector not used for this application).

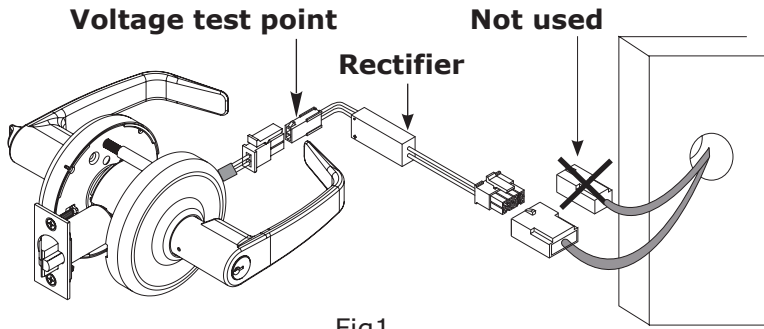

Fig1

- Install Lock per instruction sheet FM533
- Plug 8-Pin Door connector into 8-Pin Hinge connector (4-Pin Door connector not used for this application).

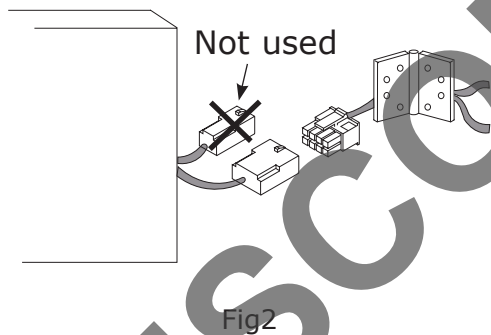

Fig2

- Wire Hinge to power source

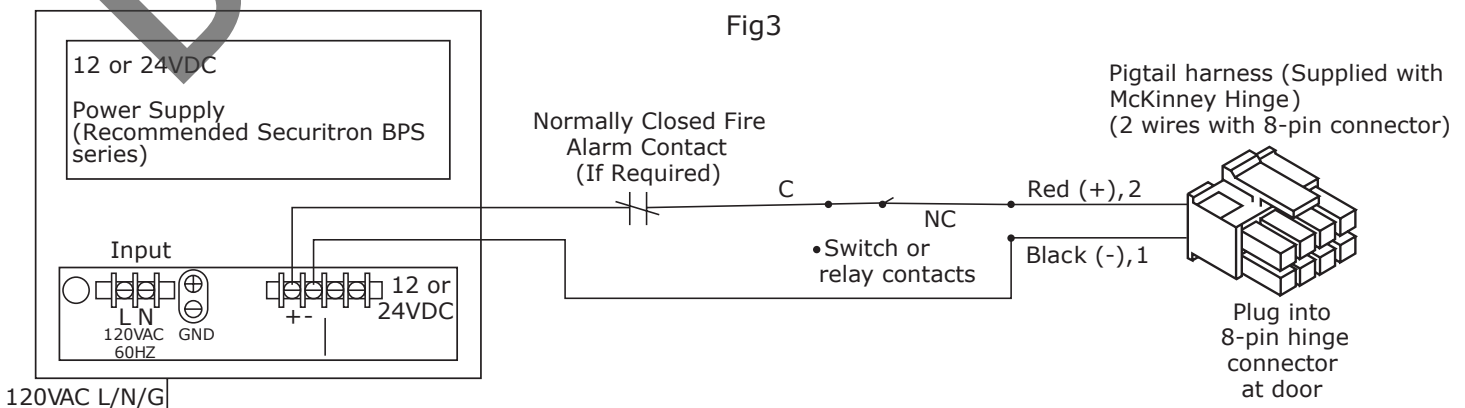

Fig3

For Non ElectroLynx Connector System Door:
Install available Retrofit Harness and use with ElectroLynx Hinge. Follow installation instructions for ElectroLynx Connector System

For Non ElectroLynx Connector System Door and Hinge: Remove connector on Lock (warranty void if rectifier module is removed). Use proper crimp splices or wire nuts in accordance with local code for terminating connections. No polarity of wires is required

Use template T30971 for door preparation

Verify Voltage is within specification after the Rectifier (see Fig1)

Electrical Specifications:
24 Volts AC/DC +/- 10%
Operating Current .150 AMP
12 Volts AC/DC +/- 10%
Operating Current .250 AMP

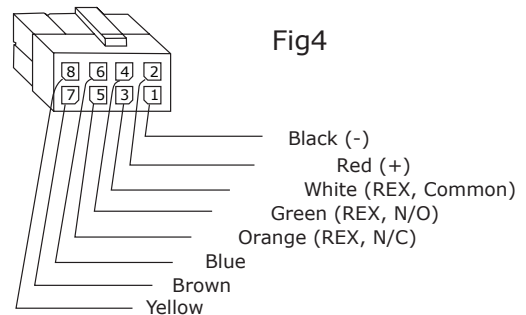

Fig4

8-Wire with 8-Pin Connectors