

Installation Instructions



ASSA ABLOY

Grade 1 Key-In-Lever Cylindrical Lockset CL3300 Series

In U.S.:
Corbin Russwin, Inc.
225 Episcopal Road
Berlin, CT 06037 USA
www.corbinrusswin.com

In Canada:
ASSA ABLOY Door Security Solutions Canada
160 Four Valley Drive
Vaughan, Ontario, Canada L4K4T9
www.assaabloy.ca

Technical Product Support: Phone: 888-607-5703

IMPORTANT: The accuracy of the door preparation is critical for the proper functioning and security of this lever handle lock. Misalignment can cause premature wear and a lessening of security.

***Standard Installation for 1-3/4" doors.
See page 2 to adjust for other door thicknesses.**

Attention Installer

Please read these instructions carefully to prevent missing important steps.

Please note: Improper installation may result in damage to the lock and void the factory warranty.

- A Install Latchbolt** → ① → ②
- B Install Lockbody** → ③
- C Install Inside Trim**
→ ④ → ⑤ → ⑥ → ⑦

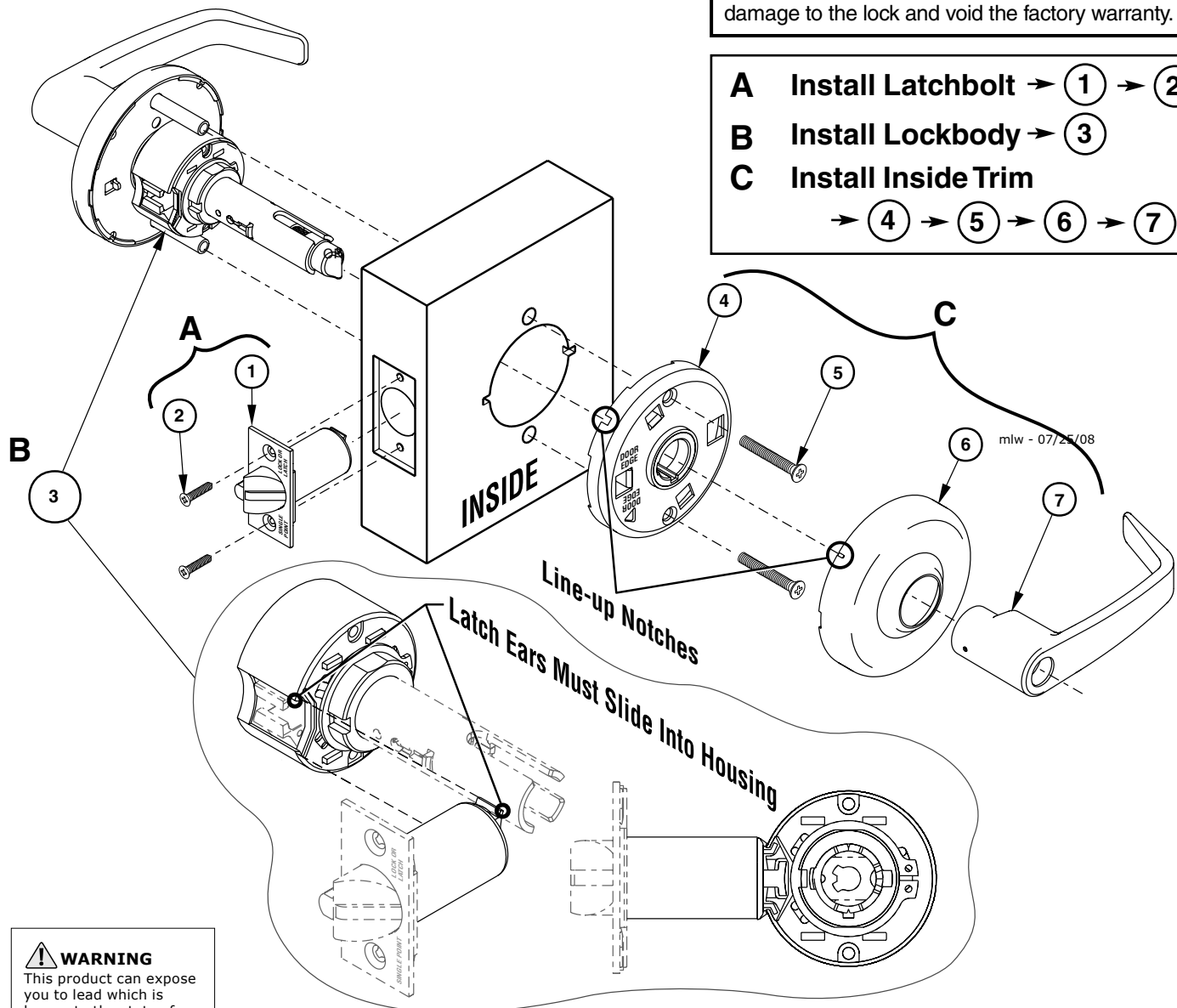

! WARNING
This product can expose you to lead which is known to the state of California to cause cancer and birth defects or other reproductive harm. For more information go to www.P65warnings.ca.gov.
08/2018



TEST OPERATION: Rotate levers to see that latchbolt moves freely.
DO NOT FORCE.

If lockset does not operate properly, remove lockset from door and check door preparation.

Door & Frame Preparation

Mark door

Locate and mark horizontal center line at desired height above floor. Fold template over edge of door, centering on horizontal line. Mark centers of holes at proper backset. Mark both sides of the door.

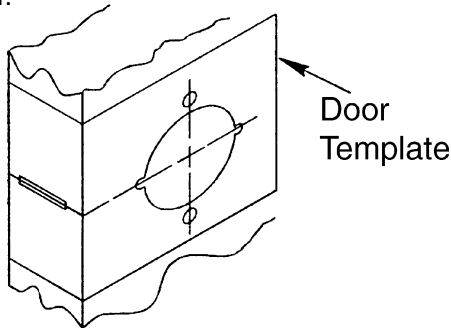

Note:
Be sure to verify backset before marking & drilling door.

Drill door

- 2-1/8" (54mm) hole thru door.** Cut ANSI tab notches as shown on template (except CL3350 and CL3370).
- Drill 1" (25mm) hole in edge of door.** Cut out for latch front 5/32" (4mm) deep. 1-1/8" (29mm) wide x 2-1/4" (57mm) high. Check latch unit for proper width front and square or round corners (except CL3350 and CL3370).
- Drill two (2) 11/32" (8mm) Dia. holes through door for all functions.**

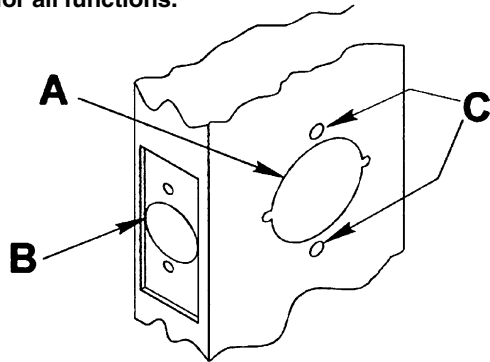

Caution:
To avoid splintering wood doors, drill holes from both sides.

Install Strike

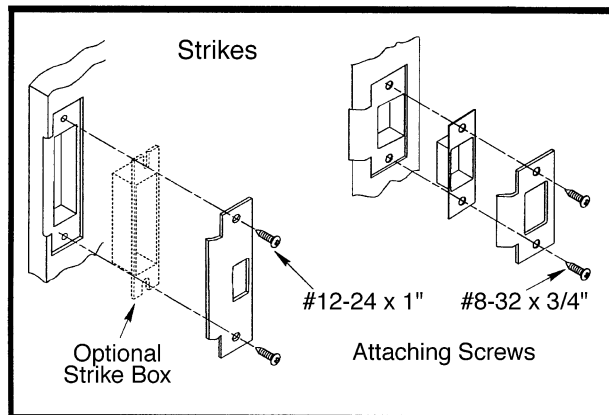

Adjust Lock for Door Thickness

Adjust lock to door thickness if other than 1-3/4" (44mm) doors*. (Lock pre-set from factory for 1-3/4" door).

- Remove outside lever (see page 4)
- Slide off outside cassette assembly.
- Rotate rose liner to adjust lock to fit door thickness, so that the distance (Dim. "A") from the inside of the liner to the centerline of the retractor is one half of the thickness of the door (see chart).
- Re-assemble outside cassette assembly onto chassis assembly (except CL3380 and CL3381 functions).

***Note: For doors more than 2", verify lock package is labeled with "D214" option.**

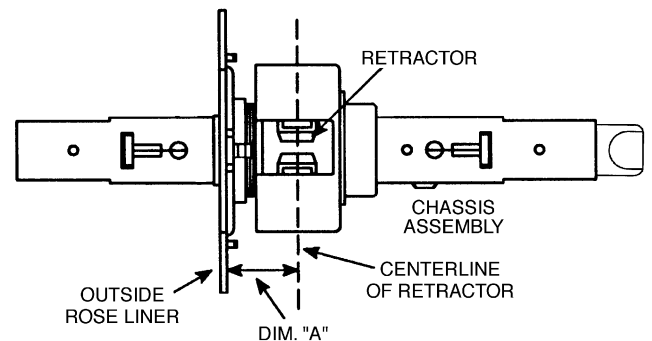
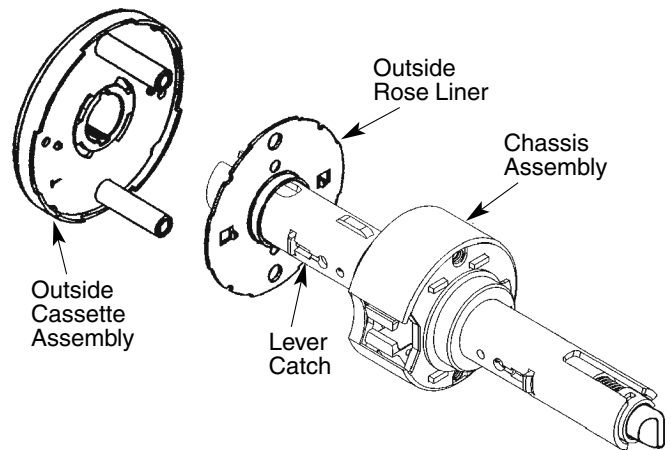

Door Thickness*	"A"
1-3/4" (44)	7/8" (22)
2" (50)	1" (25)
2-1/4" (57)	1-1/8" (29)

Dimensions are given in inches (mm).

Cylinder Installation

To Install Interchangeable Core (With lever already installed on lock)

A. Install Tailpiece

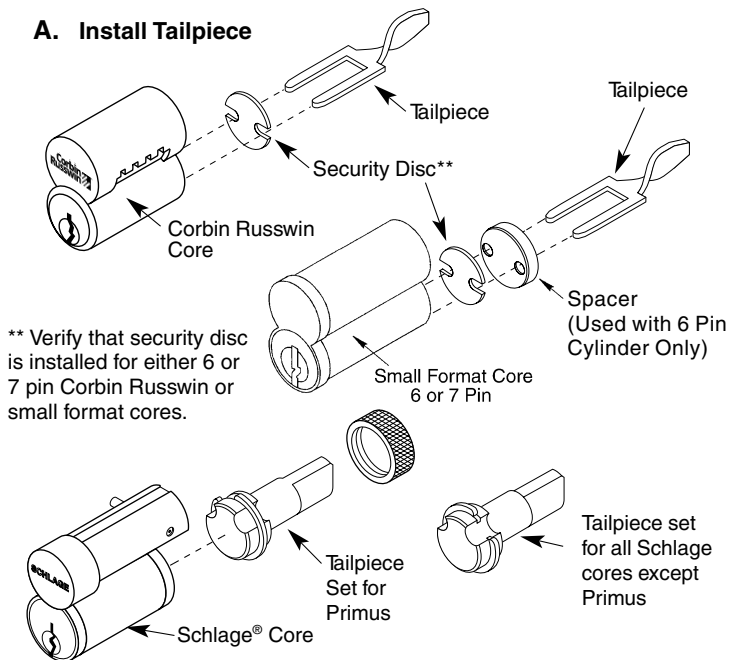

** Verify that security disc is installed for either 6 or 7 pin Corbin Russwin or small format cores.

B. Insert key marked CONTROL and turn clockwise approximately 15 degrees. See Figure 2.

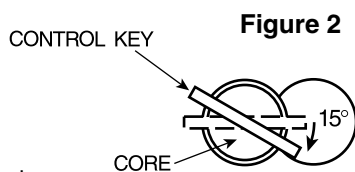

Figure 2

C. Insert core into lever and return key to its original horizontal position locking core in place. See Figure 3.

INTERCHANGEABLE CORE LEVER ASSEMBLY

D. Withdraw key. Test lockset for correct function with operating key.

E. Control key has no further use in lockset installation and must be safeguarded for return to Security personnel when installation is complete.

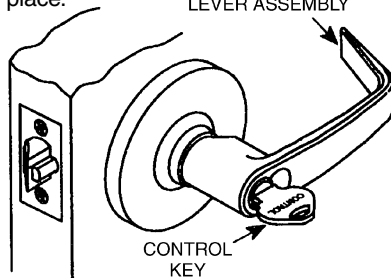
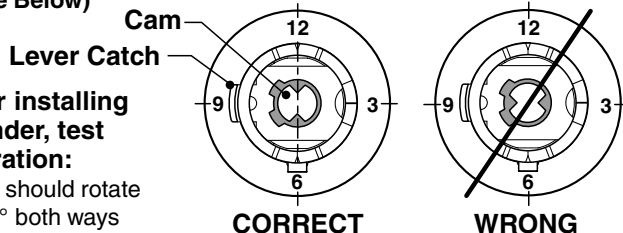

Figure 3

CL3355 Classroom or CL3352 Intruder (outside cylinder) Function Timing

Before installing cylinder:

- Turn Cam so points are up and down, 6 o'clock and 12 o'clock (See Below)



After installing cylinder, test operation:

- Key should rotate 180° both ways
- If cylinder rotates 360°, remove cylinder and check cam orientation.

Other product brand names may be trademarks or registered trademarks of their respective owners and are mentioned for reference only.

To Remove Interchangeable Core

- Insert key marked CONTROL and turn clockwise approximately 15 degrees. See Figure 4.
- Pull core and tailpiece completely out of lever.

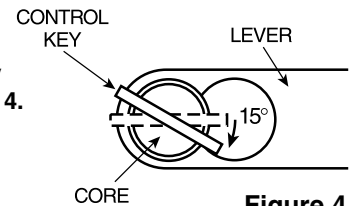
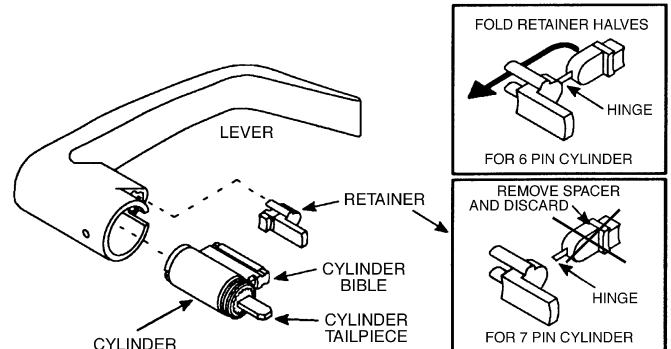

Figure 4

Install Standard Cylinder

Make sure lock is unlocked.

- Make sure cylinder tailpiece is aligned in same direction as cylinder bible. Slide cylinder all the way into lever.
 - For 6-pin cylinder: Fold retainer at hinge and press fit retainer halves together as shown.
 - For 7-pin cylinder: Break retainer at hinge and discard spacer section. Also remove black cylinder spacer from inside of chassis rollback for clearance.



Standard Cylinder Tailpieces

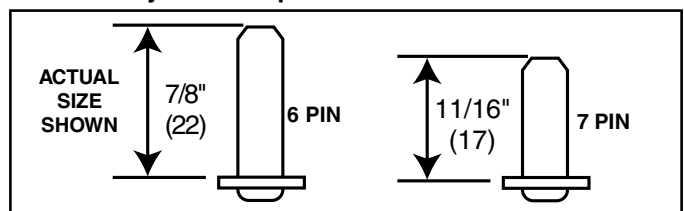

Dimensions are given in inches (mm).

Corbin Russwin conversion kit for Schlage® cylinders with CL3300 lockset.

- Remove threaded collar and Schlage® tailpiece.

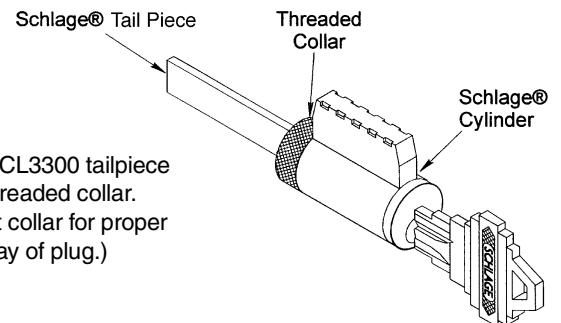

- Install CL3300 tailpiece with threaded collar. (adjust collar for proper end play of plug.)

LEVER STYLE	REMOVAL	INSTALL
Push / Turn Button 	<p>Hold in button, push release tool into release hole, remove lever</p>	<p>Push button in, slide lever on.</p> <p><i>Make sure lever will not pull off</i></p>
Plain Lever 	<p>Push release tool into release hole, remove lever</p>	<p>Slide lever over lever catch.</p> <p><i>Make sure lever will not pull off</i></p>
Cylinder Lever 	<p>Rotate key 45° clockwise (from shed position), Push in release tool into release hole, remove lever</p>	<p>Insert key and rotate 45° (from shed position), slide lever on.</p> <p><i>Make sure lever will not pull off</i></p>
Interchangeable Core Lever 	<p>Remove cylinder and tailpiece, (see page 3) Use flat blade screwdriver to pull back lever catch, remove lever</p>	<p>Slide lever over lever catch</p> <p><i>Make sure lever will not pull off</i></p>

Optional Installations

For CL3380 & CL3381 Function Only.

For CL3390 & CL3391 Function Only.

