

DC3200 Series
Multi-Sized 1 thru 6

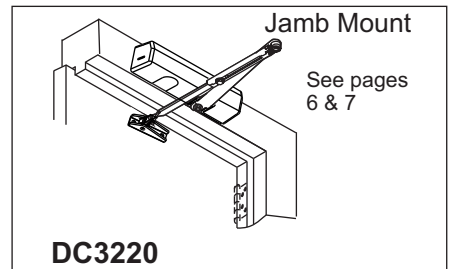

ASSA ABLOY
Universal Door Closers

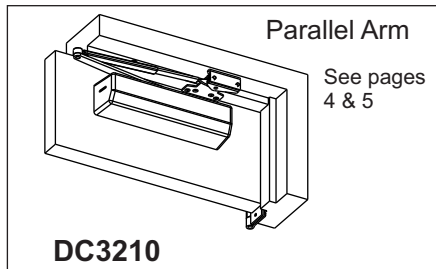
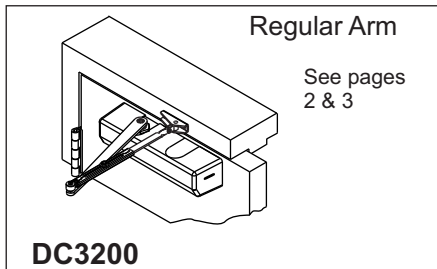

IMPORTANT:

- An improperly installed or incorrectly adjusted door closer may cause **property damage** or **personal injury**; and will void product warranty.
- To avoid personal injury, **DO NOT DISASSEMBLE THIS DOOR CLOSER BODY.**
- Door closers must be securely fastened to a properly reinforced door and frame with fasteners provided.
- Door closers with the "A1" HOLD OPEN ARM option are not permitted to be installed in fire door assemblies.

BEFORE INSTALLING:



- The Americans with Disabilities Act (ADA) requires that doors having door closers have an opening force not to exceed 5 lbf. for interior doors, 8.5 lbf exterior doors. Use standard templating for regular arm and parallel arm applications. Jamb mounted applications use the template for 140° door opening to achieve the required opening force.
- The door closer's power size adjustment feature may require adjustment to its lowest setting to comply with ADA opening force guidelines.
- ADA compliant closers are: DC3200, DC3210, DC3220

Size of Door & Door Closer

| Type of Installation | Interior | Exterior In-swinging | Exterior Out-swinging | Recommended Closer Size | **Max. Opening Force lbs/f |
|----------------------|----------|----------------------|-----------------------|-------------------------|----------------------------|
| Regular & Top Jamb | 2'4" | — | — | 1 | 8 |
| | 3'0" | — | — | 2 | 14 |
| | 3'6" | 2'6" | 3'0" | 3 | 16 |
| | 4'0" | 3'0" | 3'6" | 4 | 22 |
| | 4'6" | 3'6" | 4'0" | 5 | 24 |
| | 5'0" | *4'0" | *4'6" | 6 | 26 |
| Parallel Arm | 2'4" | — | — | 1 | 8 |
| | 2'6" | — | — | 2 | 14 |
| | 3'0" | — | 2'6" | 3 | 16 |
| | 3'6" | — | 3'0" | 4 | 22 |
| | 4'0" | — | *3'6" | 5 | 24 |
| | 4'6" | — | *4'0" | 6 | 26 |

TO DETERMINE HAND OF YOUR DOOR:

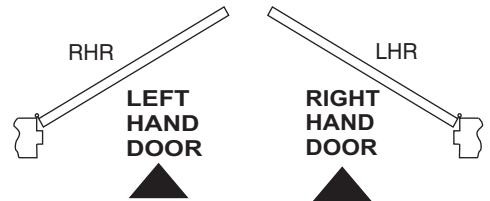

**NOTE: These forces are for standard templating with bearing type hinges and do not account for pressure differentials and draft.

Installation Instructions

Regular Arm Application DC3200 Series

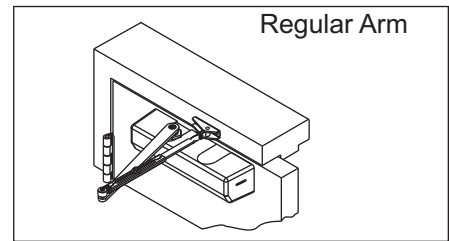

1. Template

Mark Door and Jamb (for closer bracket and arm bracket)

If top rail is 2-1/2" (64mm) or greater, use template FM131C provided.

If top rail is 1-3/4" (44mm) to 2-7/16 (62mm), see MOUNTING DIMENSIONS chart.

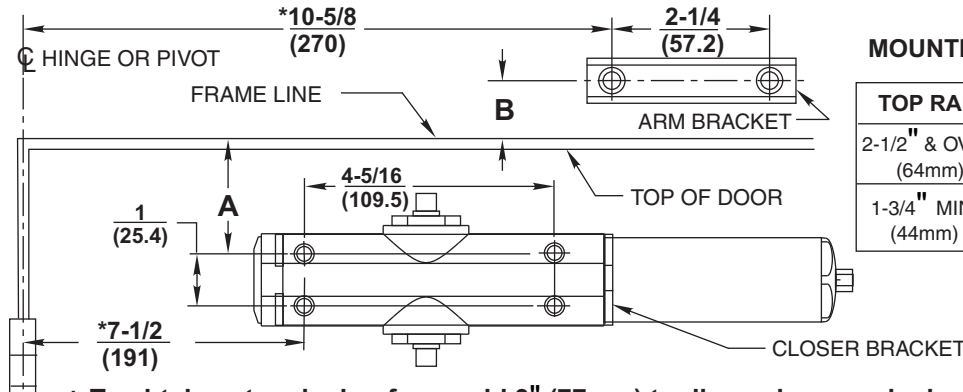

MOUNTING DIMENSIONS

| TOP RAIL | A | B | MIN. CLEARANCE REQUIRED OVER DOOR | |
|-------------------------|----------------|------------------|-----------------------------------|--------------------|
| | | | NHO | HO |
| 2-1/2" & OVER (64mm) | 1" (25.4mm) | 7/8" (23mm) | 1-1/2" (39mm) | 1-11/16" (43mm) |
| 1-3/4" MIN. (44mm) | 5/8" (16mm) | 1-1/4" (32mm) | 1-7/8" (48mm) | 2-1/16" (53mm) |

*** To obtain extra closing force add 3" (77mm) to dimensions marked. This will limit degree of door opening to 110°.**

MOUNTING SCREW SPECIFICATIONS

ARM AND CLOSER BRACKET

1/4-20 oval head machine screw
or 1/4-14 self-drilling screw.
3/16 (4.8) diameter pilot hole
required for Wood Applications.

or { Option M54:
Sex nuts, furnished
when ordered

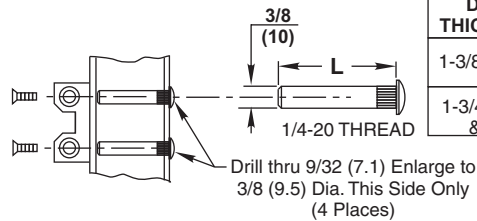

| DOOR THICKNESS | SEX NUT LENGTH "L" |
|----------------------|--------------------|
| 1-3/8" (35mm) | 1-9/32" (33mm) |
| 1-3/4" (44mm) & OVER | 1-21/32" (42mm) |

NOTES:

- Check hand of door, see page 1.
- Right Hand Application Shown. Left Hand Opposite.
- Dimensions given in inches (mm). Do Not Scale Drawing.
- Closer must be installed in a true horizontal plane to ensure proper closer performance.
- Door opening (up to 180°) is dependent upon door, frame, wall and hinge/pivot conditions permitting.

2. Install Closer Bracket

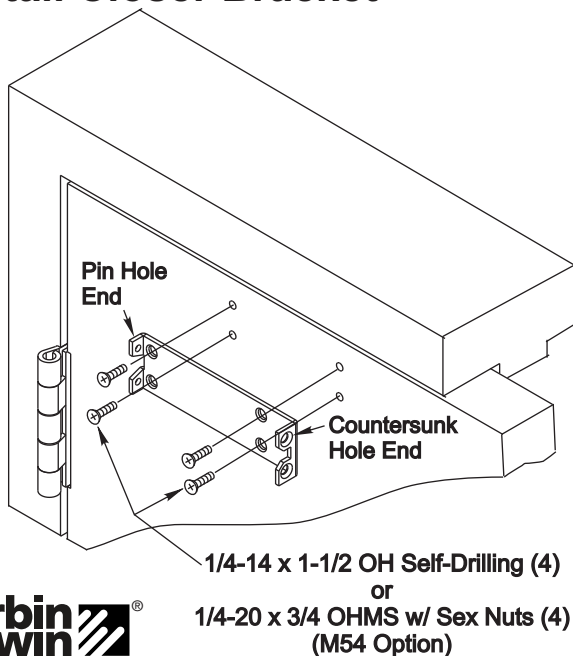

3. Mount Closer Body to Closer Bracket

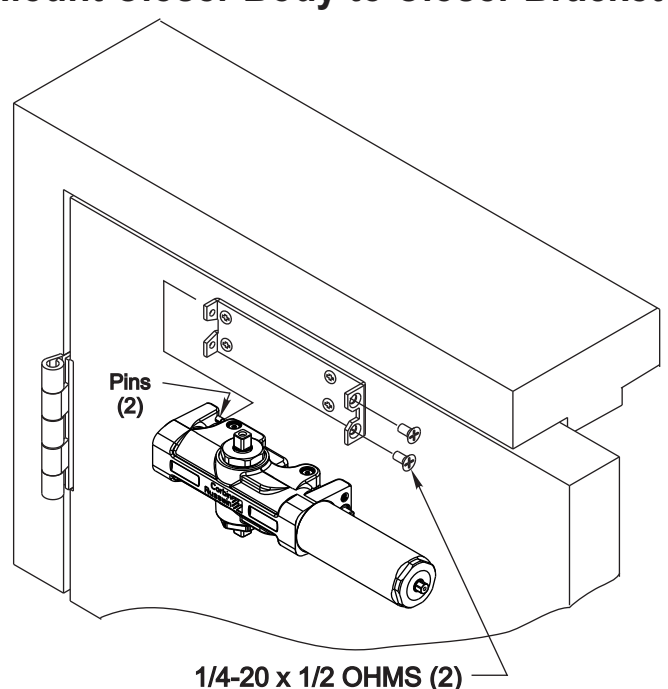

ASSA ABLOY

Regular Arm Application (Continued)

4a. Attach Arm Bracket to Frame NON-HOLD OPEN ARM ONLY:

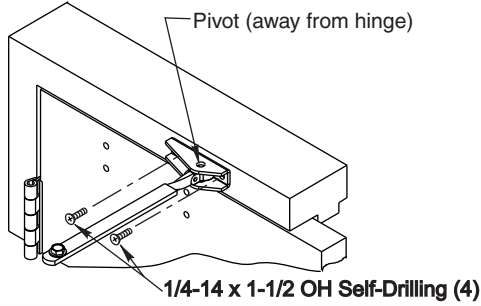

Standard Position

Normal mounting position. Position with pivot point away from hinge.

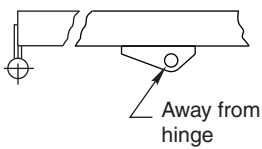

For Additional 15% Closing Force

Reposition arm mounting bracket so that pivot point is toward hinge.

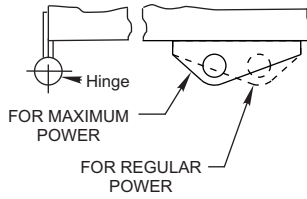

4b. Attach Arm Bracket to Frame HOLD OPEN ARM (A1 OPTION ONLY):

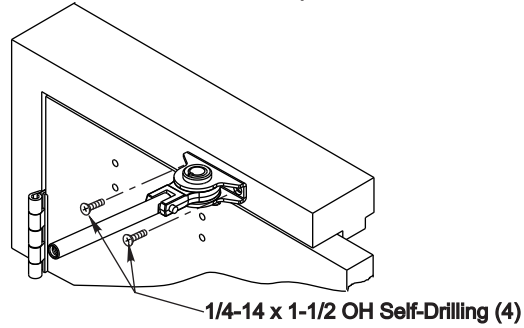

HOLD OPEN ARM:

Position so that dial screw is on UNDERSIDE of bracket

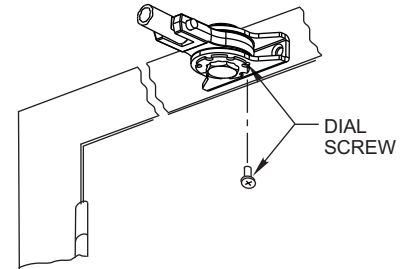

5a. Position Arm on Closer NON-HOLD OPEN ARM ONLY:

Main arm projects straight out at 90° angle to door.

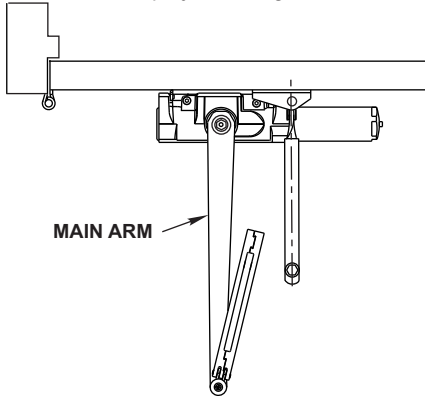

5b. Position Arm on Closer HOLD OPEN ARM ONLY:

Main arm projects straight out at 90° angle to door. Remove main arm screw from elbow joint and disassemble arm. Thread the rod into the Arm Bracket as shown below.

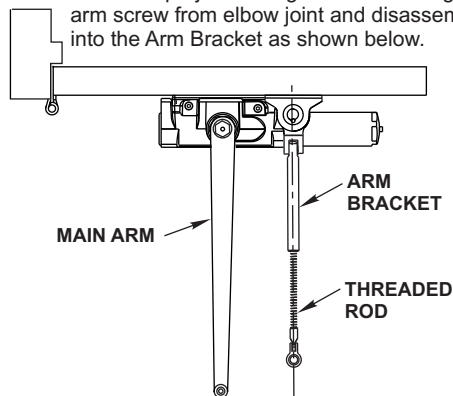

6a. Preload and Adjust Arm NON-HOLD OPEN ARM ONLY:

Open door and slide arm rod into arm loop. Close door, swing arms so adjusting arm is 90° to frame. With 7/16" wrench **INSTALL and TIGHTEN SCREW SECURELY.**

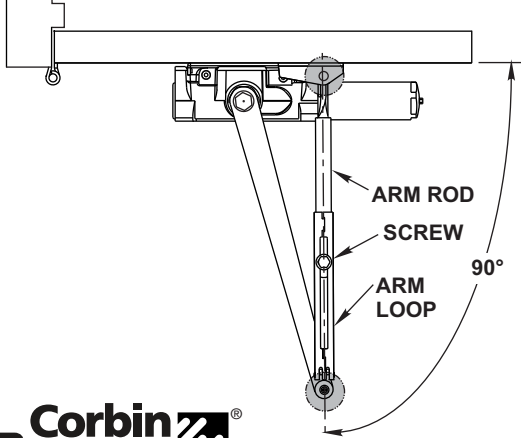

6b. Preload and Adjust Arm HOLD OPEN ARM ONLY:

While door is closed, adjust the Threaded Arm in the Arm Bracket until the bearing fits back onto the elbow joint on the Main Arm at 90° as shown below. **RE-INSTALL AND TIGHTEN SCREW SECURELY.**

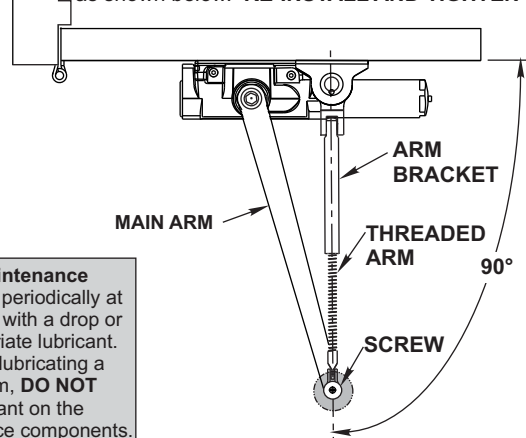

Extended Maintenance
Lubricate Arm periodically at shaded points with a drop or two of appropriate lubricant.
NOTE: When lubricating a Hold Open Arm, **DO NOT** use any lubricant on the Holding Surface components.

**Corbin
Russwin**

ASSA ABLOY

80-9330-3000-152 Rev. 05/12

For Adjustments See Page 8

ASSA ABLOY, the global leader in door opening solutions

Installation Instructions

Parallel Arm Application DC3210 Series

1. Template

Mark Door and Jamb (for closer bracket and adapter plate)

Use template FM131C provided or use dimensions in this template.

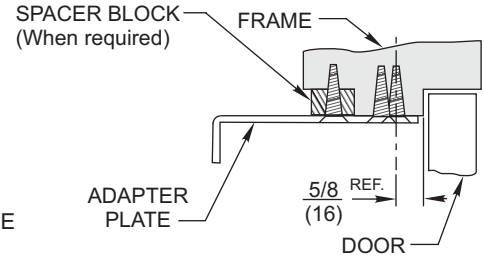
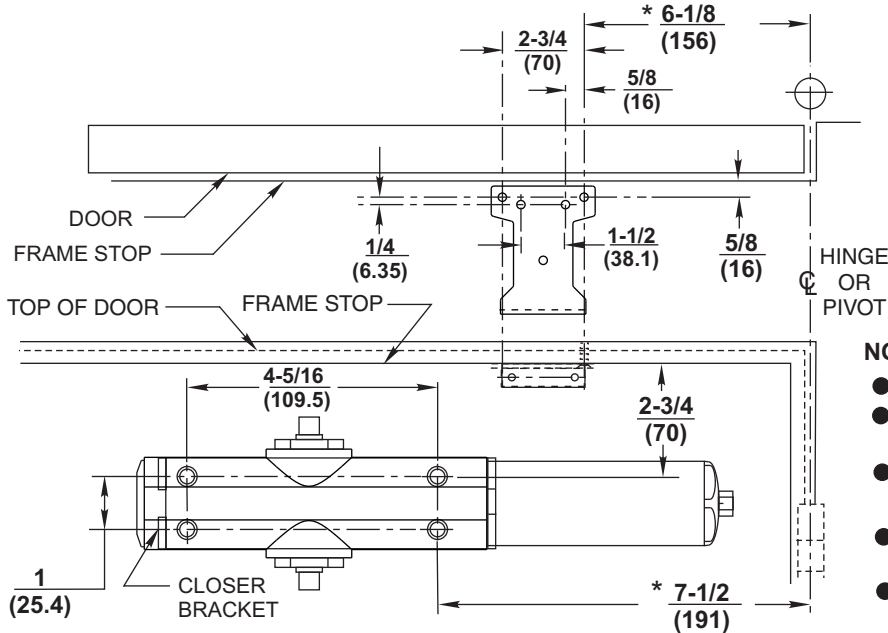
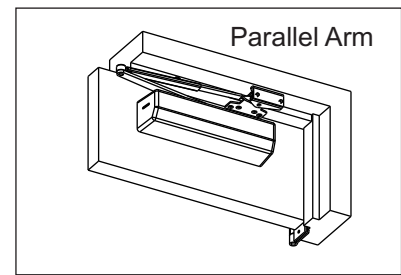

NOTES:

- Check hand of door, see page 1.
- Right Hand Application Shown. Left Hand Opposite.
- Dimensions given in inches (mm). Do Not Scale Drawing.
- Closer must be installed in a true horizontal plane to ensure proper closer performance.
- Door opening (up to 180°) is dependent upon door, frame, wall and hinge/pivot conditions permitting.

* To obtain extra closing force add 3" (77mm) to dimensions marked. This will limit degree of door opening to 110°.

MOUNTING SCREW SPECIFICATIONS

ARM AND CLOSER BRACKET

1/4-20 oval head machine screw or 1/4-14 self-drilling screw. 3/16 (4.8) diameter pilot hole required for Wood Applications.

or { Option M54: Sex nuts, furnished when ordered

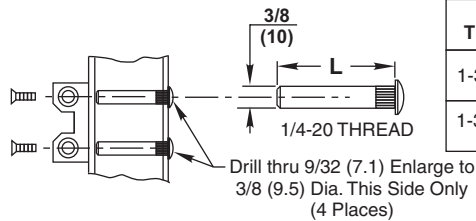

| DOOR THICKNESS | SEX NUT LENGTH "L" |
|----------------------|--------------------|
| 1-3/8" (35mm) | 1-9/32" (33mm) |
| 1-3/4" (44mm) & OVER | 1-21/32" (42mm) |

2. Install Closer Bracket

1/4-14 x 1-1/2 OH Self-Drilling (4)

or

1/4-20 x 3/4 OHMS w/ Sex Nuts (4) (M54 Option)

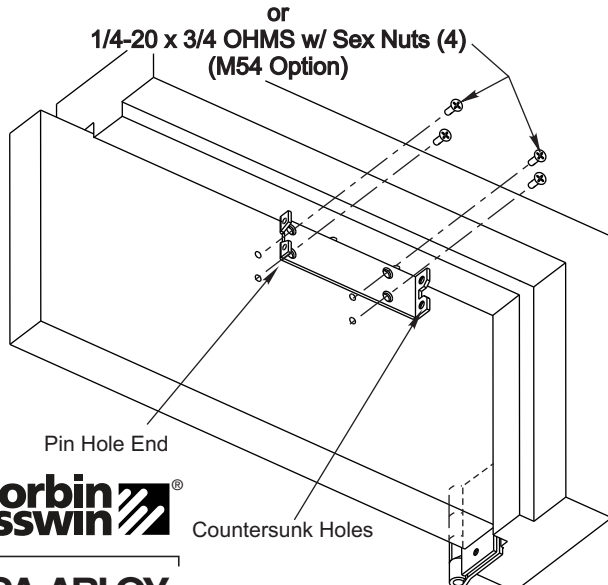

3. Mount Closer Body to Closer Bracket

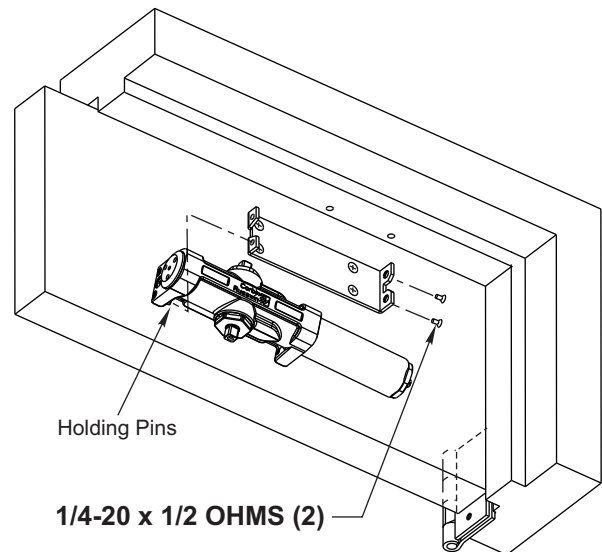

ASSA ABLOY

Parallel Arm Application (Continued)

4. Mount Adapter Plate Bracket on Jamb

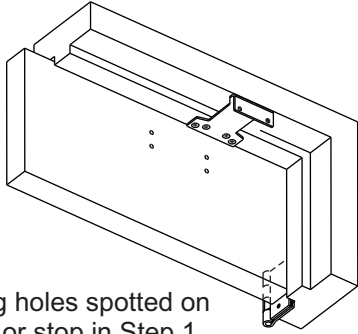

Using holes spotted on soffit or stop in Step 1 mount adapter plate bracket.

5. Mount Arm Bracket

NON-HOLD OPEN ARM:

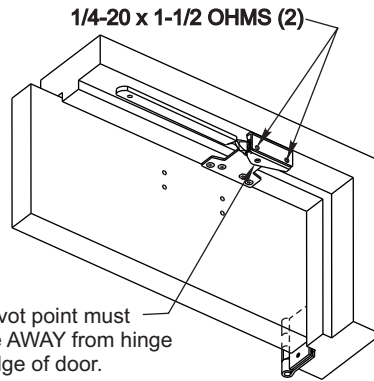

Pivot point must be AWAY from hinge edge of door.

HOLD OPEN ARM ONLY (A1 Option)

1/4-20 x 1-1/2 OHMS (2)

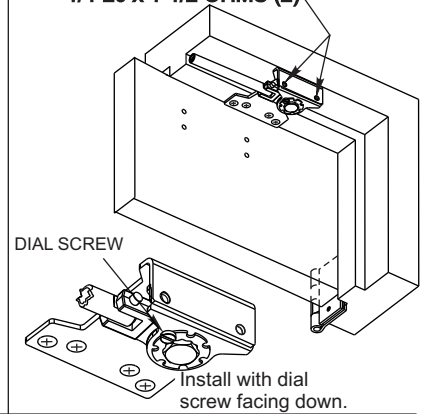

DIAL SCREW

Install with dial screw facing down.

6. Position Arm onto Closer

Using hex wrench provided, turn closing speed and latching speed valves clockwise until completely closed. DO NOT OVER TIGHTEN. Using wrench, turn under side of spindle 45° toward the closer tube until it reaches the diamond position (fig. 2). Immediately place arm on spindle so that it is parallel to the closer body. Install and tighten arm screw and washer assembly. Reopen valves.

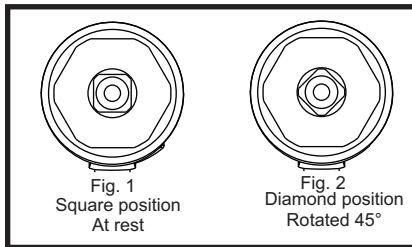
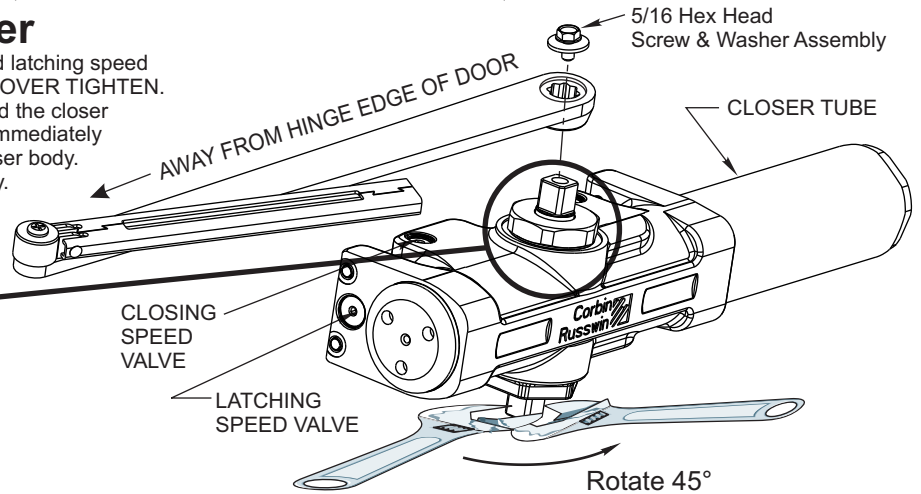

Fig. 1 Square position At rest

Fig. 2 Diamond position Rotated 45°



7. Connect and Position Arms

Open door and slide arm rod into arm loop. Close door, swing arms so that they form a "V" position, as in Step 8. With 7/16" wrench, **INSTALL AND TIGHTEN SCREW SECURELY.**

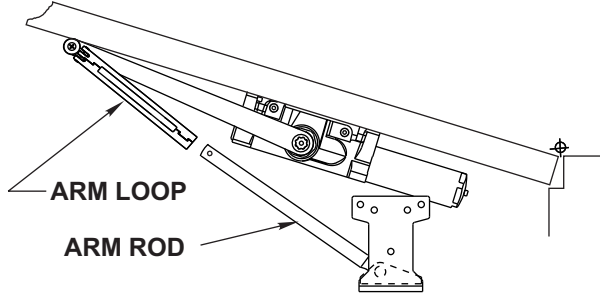

HOLD OPEN ONLY

Remove main arm screw from elbow joint and disassemble arm. Thread the rod into the Arm Bracket as shown below. While door is closed, adjust the Threaded Arm in the Arm Bracket until the bearing fits back onto the elbow joint on the Main Arm and forms a "V" as shown below. **RE-INSTALL AND TIGHTEN SCREW SECURELY.**

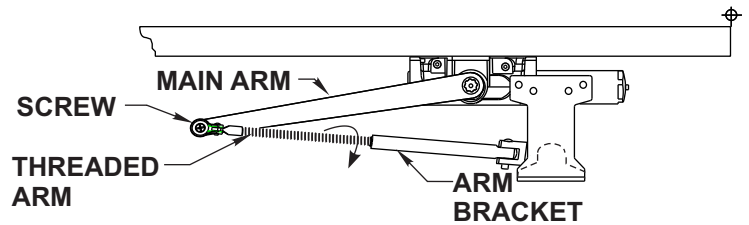

8. Power Adjustment

To increase the power of the closer, re-adjust the arm so it is nearer the door. To decrease power, re-adjust the arm so it is farther away from the door and then secure screw in arm loop (non-hold open) or elbow joint (hold open).

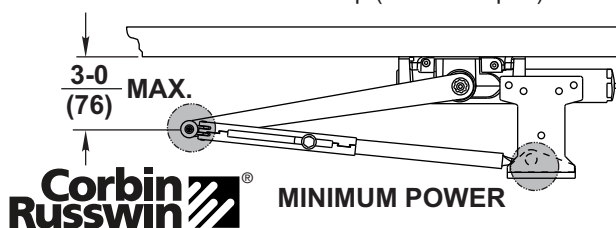

Corbin Russwin

MINIMUM POWER

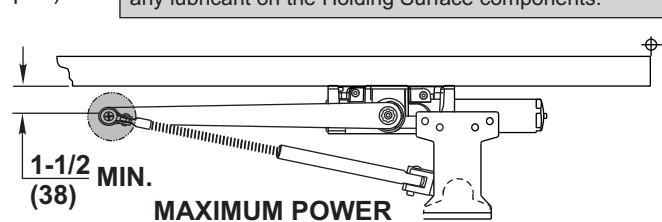

1-1/2 (38) MIN.

MAXIMUM POWER

Extended Maintenance

Lubricate Arm periodically at shaded points with a drop or two of appropriate lubricant. **NOTE:** When lubricating a Hold Open Arm, **DO NOT** use any lubricant on the Holding Surface components.

ASSA ABLOY

For Adjustments See Page 8

Installation Instructions

Jamb Mount Application DC3220 Series

1. Template

Mark Door and Jamb (for closer bracket and arm bracket)
use dimensions in template below.

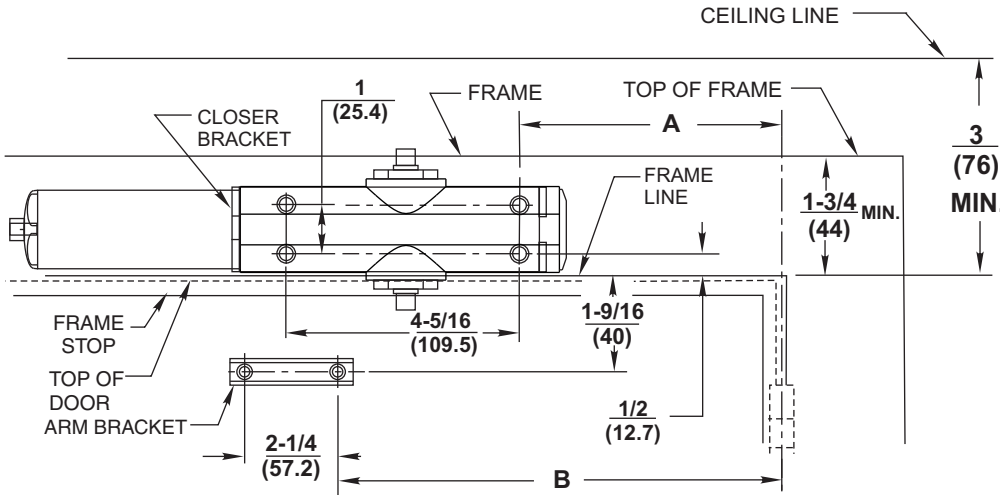
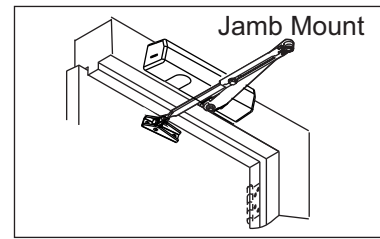

| OPENING MAXIMUM | A | B | HINGE CONDITION |
|-----------------|-------------|--------------|--|
| 110° | 8-7/8 (225) | 13-3/8 (340) | Butts, Offset Pivots, and Swing Clear Hinges |
| 140° | 7-3/8 (187) | 11-7/8 (302) | |
| 180° | 5-7/8 (149) | 10-3/8 (264) | |
| 140° | 7-3/8 (187) | 11-7/8 (302) | * CENTER HUNG |

Dimensions "A" and "B" are taken from centerline of hinge as shown and apply to pivot point of swing clear hinges. Offset and centerhung pivots.
*Must be single acting door.

MOUNTING SCREW SPECIFICATIONS

ARM AND CLOSER BRACKET

1/4-20 oval head machine screw or 1/4-14 self-drilling screw. 3/16 (4.8) diameter pilot hole required for Wood Applications.

or Sex nuts, Option M54, furnished when ordered

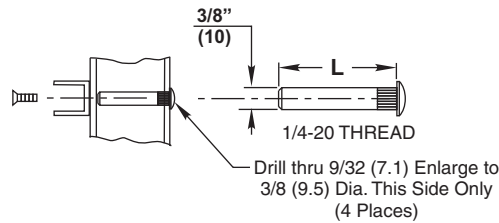

| DOOR THICKNESS | SEX NUT LENGTH "L" |
|----------------------|--------------------|
| 1-3/8" (35mm) | 1-9/32" (33mm) |
| 1-3/4" (44mm) & OVER | 1-21/32" (42mm) |

NOTES:

- Check hand of door, see page 1.
- Right Hand Application Shown. Left Hand Opposite.
- Dimensions given in inches (mm). Do Not Scale Drawing.
- Closer must be installed in a true horizontal plane to ensure proper closer performance.
- All degrees of door opening are dependent upon door, frame, wall and hinge/pivot conditions permitting.

2. Install Closer Bracket to Jamb

1/4-14 x 1-1/2 OH Self-Drilling (4)

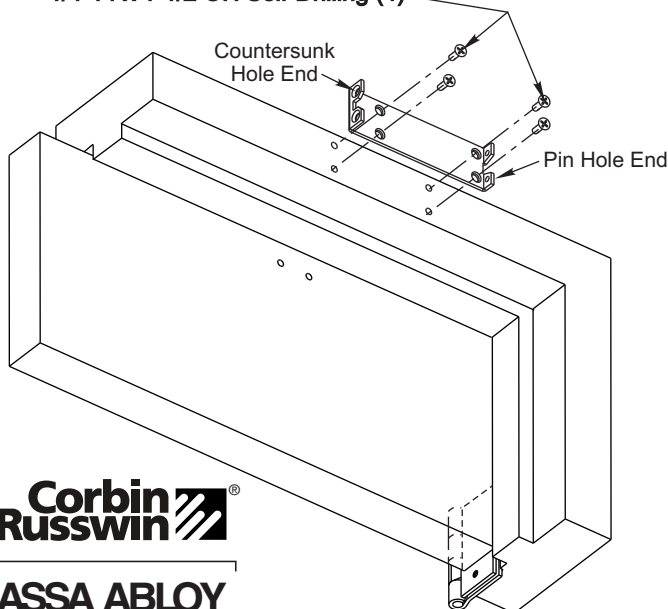

3. Mount Closer Body to Closer Bracket

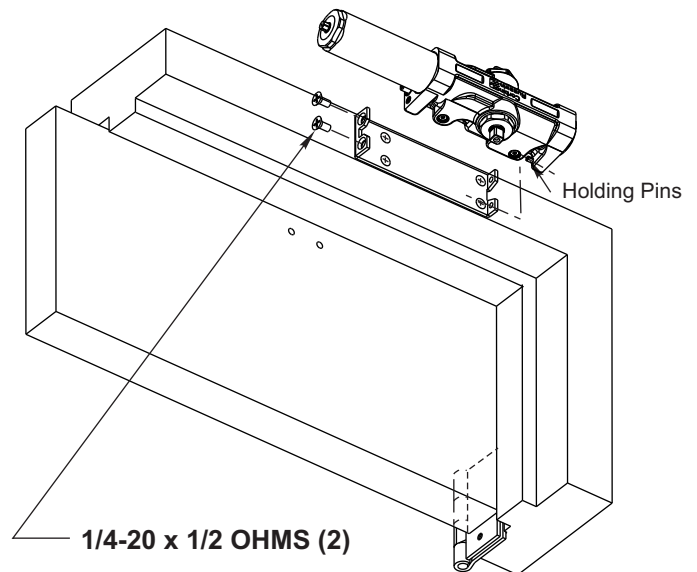

ASSA ABLOY

Jamb Mount Application (continued)

4a. Attach Arm Bracket to Door

NON-HOLD OPEN ARM ONLY:

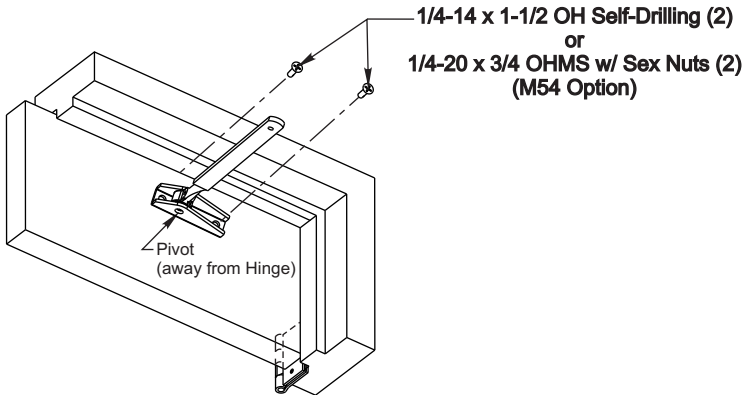

Standard Position

Normal mounting position. Position with pivot point away from hinge.

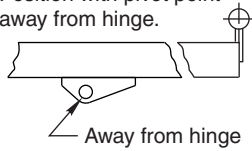

For Additional 15% Closing Force

Reposition arm mounting bracket so that pivot point is toward hinge.

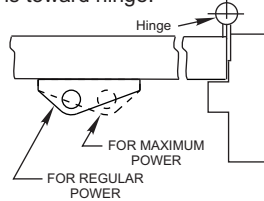

4b. Attach Arm Bracket to Door

HOLD OPEN ARM (A1 Option):

1/4-14 x 1-1/2 OH Self-Drilling (2)
or
1/4-20 x 3/4 OHMS w/ Sex Nuts (2)
(M54 Option)

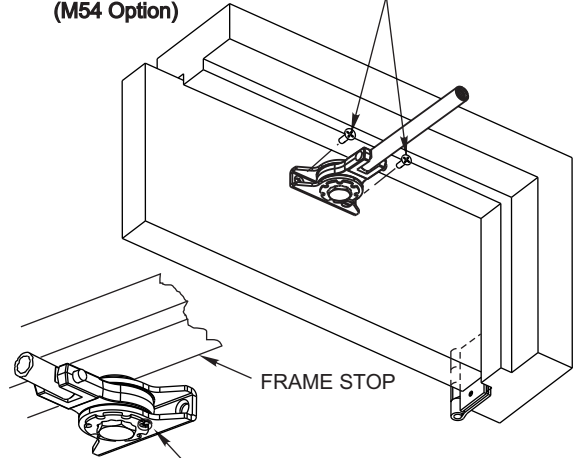

Install with dial screw facing down

5a. Position Arm on Closer

NON-HOLD OPEN ARM ONLY:

Main arm projects straight out at 90° angle to door.

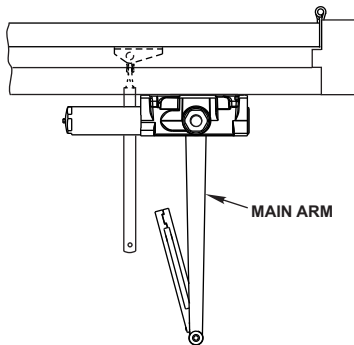

5b. Position Arm on Closer

HOLD OPEN ARM ONLY (A1 Option):

Main arm projects straight out at 90° angle to door. Remove main arm screw from elbow joint and disassemble arm. Thread the rod into the Arm Bracket as shown below.

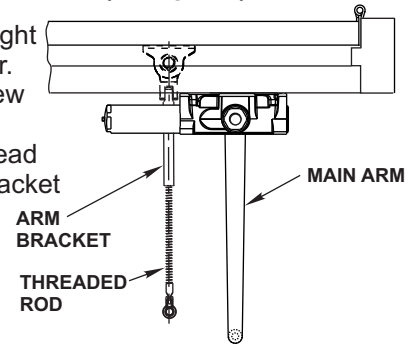

6a. Preload and Adjust Arm

NON-HOLD OPEN ARM ONLY:

Open door and slide arm rod into arm loop. Close door, swing arms so adjusting arm is 90° to frame. With 7/16" wrench, **INSTALL and TIGHTEN SCREW SECURELY.**

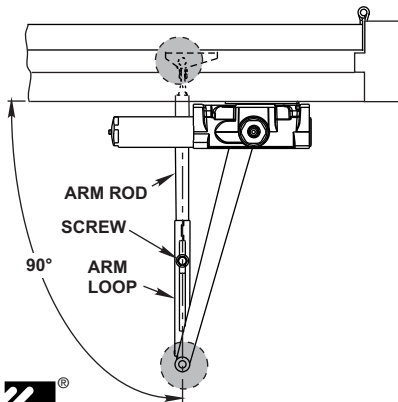

6b. Preload and Adjust Arm

HOLD OPEN ARM ONLY (A1 Option):

While door is closed, adjust the Threaded Arm in the Arm Bracket until the bearing fits back onto the elbow joint on the Main Arm at 90° as shown below. **RE-INSTALL and TIGHTEN SCREW SECURELY.**

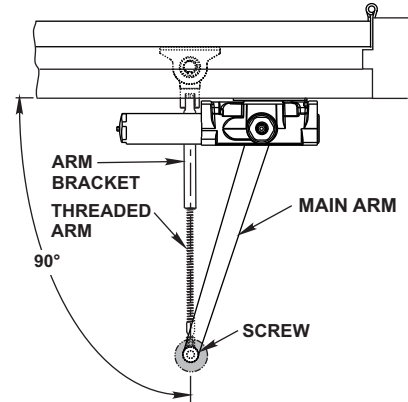

Extended Maintenance
Lubricate Arm periodically at shaded points with a drop or two of appropriate lubricant.
NOTE: When lubricating a Hold Open Arm, **DO NOT** use any lubricant on the Holding Surface components.



ASSA ABLOY

80-9330-3000-152 Rev. 05/12

For Adjustments See Page 8

ASSA ABLOY, the global leader in door opening solutions

Spring Power Adjustment

Locate spring power adjuster from illustration below
DC3200 Size 1 thru 6 Adjustment See Chart

| Interior | Size of Door | | No. of Full (360°) Turns Clockwise of Power Adjuster | Equivalent Closer Size (Approx.) |
|--------------|-------------------|--------------------|--|----------------------------------|
| | Exterior In Swing | Exterior Out Swing | | |
| 2' 4" (712) | 2' 6" (764) | | 4 | 2 |
| 2' 6" (764) | 3' 0" (915) | | 8 | 3 |
| 3' 0" (915) | 3' 6" (1067) | 2' 6" (764) | 12 | 4 |
| 3' 6" (1067) | 4' 0" (1219) | 3' 0" (915) | 16 | 5 |

DC6200 SPRING POWER ADJUSTMENT CHART

- All DC6200 closers are factory set at an approximate **Size 3**.
- Adjust closer as necessary for door size using this chart.
- Readjustment may be required to suit prevailing conditions.

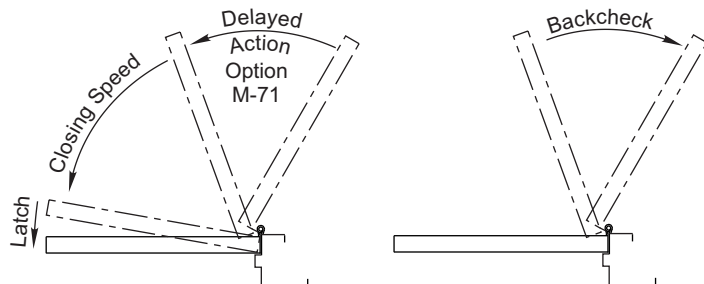
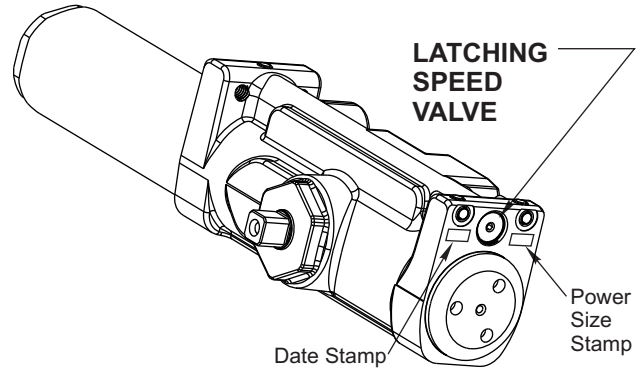
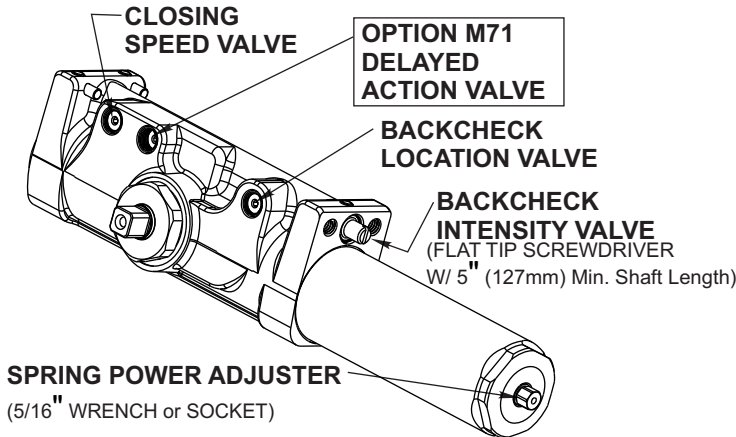

Closing Speed Valve (3/32 Allen Wrench Provided)

To adjust speed of door closing from fully open to a position 2" to 5" from closed, turn Closing Speed Valve **CLOCKWISE** to SLOW closing, **COUNTER-CLOCKWISE** to SPEED closing.

Latching Speed Valve (3/32 Allen Wrench Provided)

After closing speed has been obtained, turn latching speed valve **CLOCKWISE** to SLOW latching or **COUNTER-CLOCKWISE** to SPEED latching for last 2" to 5" of door travel.

NOTE: Set combination of CLOSING and LATCHING speeds to between 3 and 7 seconds Use of door by handicapped, elderly or small children may require even greater closing time.

Delayed Action Valve (3/32 Allen Wrench Provided)

Turn valve **CLOCKWISE** to SLOW closing, **COUNTER-CLOCKWISE** to SPEED closing. Delayed action may be adjusted from 20 seconds to 90 seconds, depending on degree of door swing. Delay occurs at the beginning of the door closing cycle from fully open down to 70°, where the closing speed valve then begins its control.

Backcheck Intensity Valve

Turn valve **COUNTER-CLOCKWISE** to reduce backcheck or **CLOCKWISE** to increase backcheck. (Backcheck should be set to give a soft cushioning action, not a sudden stop.)

Installing Cover



Full Cover (Standard)

Slip cover over closer. Hold tightly against closer mounting surface. Secure on each side with 6-32 x 1/4" PBHMS screws.

To Adjust Hold Open (A1 Option)

Open the door to desired position and tighten the hold open screw firmly (For RH application, turn screw on underside **CLOCKWISE**. For LH application, turn screw **COUNTER-CLOCKWISE**.) Place the hold open dial over the hex head of the bracket screw so that one of the slots in the dial is directly over small screw hole tapped in bracket. Seat the dial tightly over the bracket. **INSERT DIAL SCREW AND TIGHTEN SECURELY.**

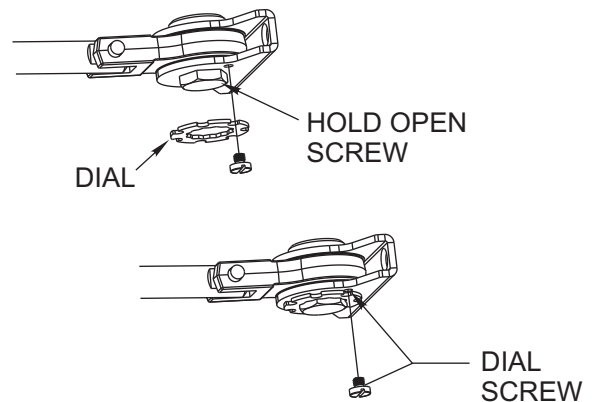

**Corbin
Russwin**

ASSA ABLOY

80-9330-3000-152 Rev. 05/12

Copyright© 2005, 2012 Corbin Russwin, Inc., an ASSA ABLOY Group company. All rights reserved. Reproduction in whole or in part without the express written permission of Corbin Russwin, Inc. is prohibited.

ASSA ABLOY, the global leader in door opening solutions