

MOUNTING INFORMATION

Sex nuts or through bolts are required for wood and plastic covered composite doors, and any type of door without reinforcements and recommended for wood core and metal clad (Kalamein) type doors unless door manufacturer has a listed alternative means for fastening door hardware.

RESPONSIBILITY

Door and Frame Manufacturers are responsible for providing adequate construction or reinforcements for proper installation of hardware shown. All architectural builders hardware must be installed on properly reinforced doors and frames, regardless of the type, material, or method of construction.

RH SHOWN
 LH OPPOSITE

CAUTION: CLOSER TO BE INSTALLED IN A TRUE HORIZONTAL POSITION TO ENSURE PROPER CLOSER PERFORMANCE.

MOUNTING SCREW SPECIFICATIONS
 ARM AND CLOSER BRACKET

DOOR THICKNESS	SEX NUT LENGTH "L"
1-3/8" (35mm)	1-9/32" (33mm)
1-3/4" (44mm) & OVER	1-21/32" (42mm)

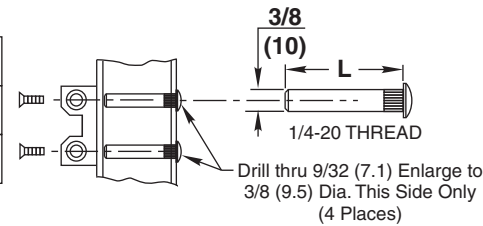

1/4-20 oval head machine screw or 1/4-14 self-drilling screw Type BSD

- or -

Option M54: Sex nuts, furnished when ordered

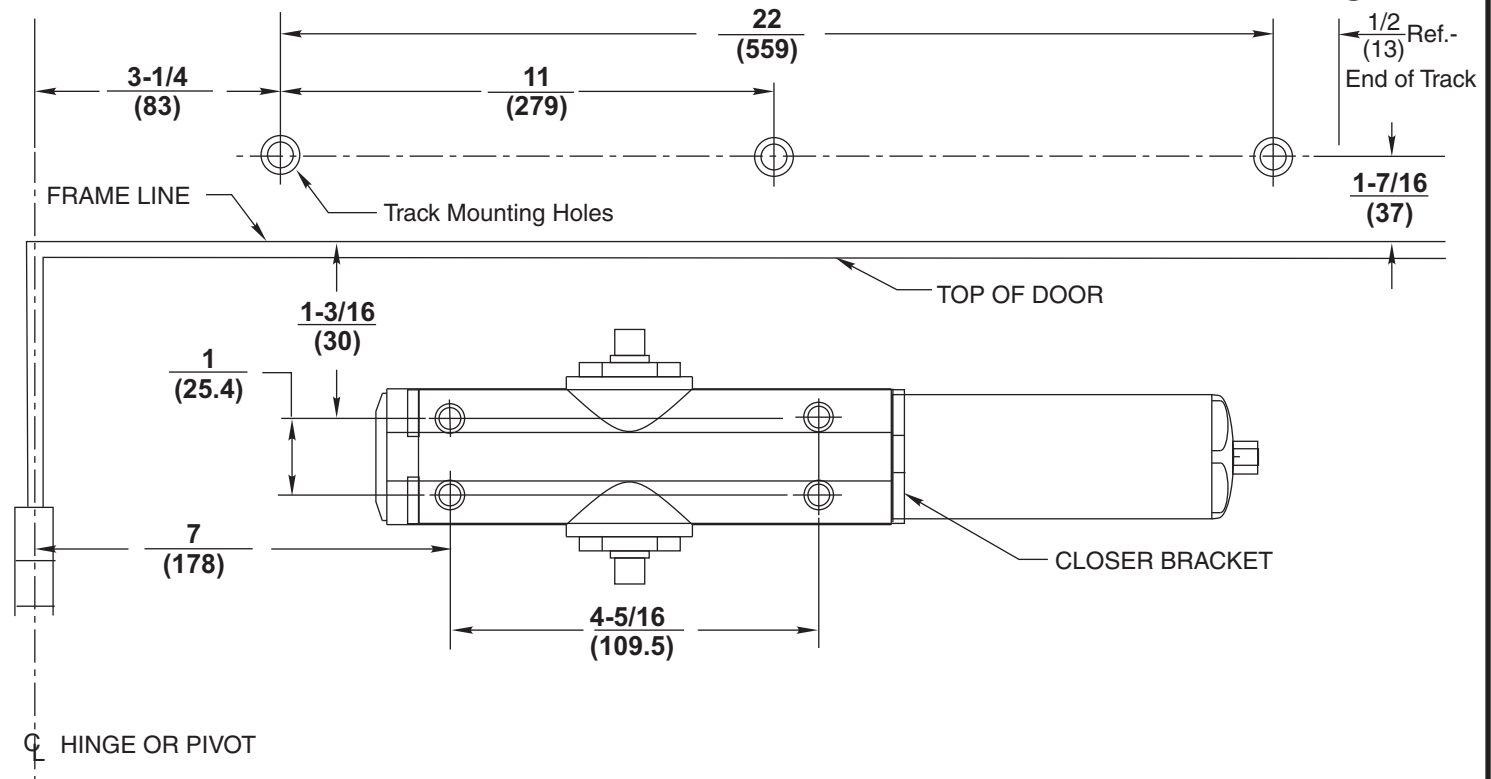

①

- NOTES:**
1. Hold-open may be set from 85° to 105° positions.
 2. Maximum degree of opening is 110°. All degrees of opening are based on use of butt hinges or 3/4" (19) offset pivots.
 3. Dimensions given in inches and (mm).
 4. Door closer with cover has a projection of 2-3/4" (70) from door.
 5. Minimum ceiling clearance is 3" (76).

DC6230 or DC6430 Series

**Surface Door Closer with Track
 Pull Side, Door Mounted Closer**



ASSA ABLOY

www.corbinrusswin.com

SUPERSEDES T31038 DO NOT SCALE DRAWING

TEMPLATE NUMBER T31038-1 DATE 04-08