

MOUNTING INFORMATION

Sex nuts or through bolts are required for wood and plastic covered composite doors, and any type of door without reinforcements and recommended for wood core and metal clad (Kalamein) type doors.

RH SHOWN
LH OPPOSITE

CAUTION: Closer To Be Installed In A True Horizontal Position To Ensure Proper Closer Performance.

MOUNTING SCREW SPECIFICATIONS
ARM AND QUIK-INSTALL™ BRACKET

#12-14 self-drilling screw.
1/8 (3) diameter pilot hole } or { Sex nuts, furnished
required for Wood } when ordered
Applications.

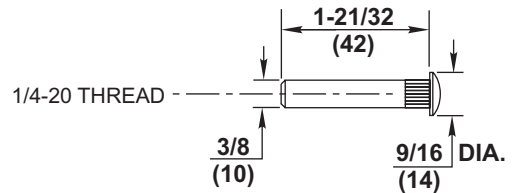

NOTES:

1. Dimensions given in inches and (mm).
2. Minimum Top Rail: 1-1/4 (32)
3. Minimum Clearance Over Door: 1-5/8 (41).
4. Door opening (up to 180°) is dependent upon door, frame, wall and hinge/pivot conditions permitting.
5. Auxiliary door stop required, by others.
6. To obtain extra closing force, add 3 (76) to dimensions marked by an astrisk (*). This will not meet ADA and limit degree of opening to 110° depending on arm adjustment.
7. Astrisk (*) dimensions apply to centerline of hinges or pivots.
8. Door silencers required when using sex nuts.

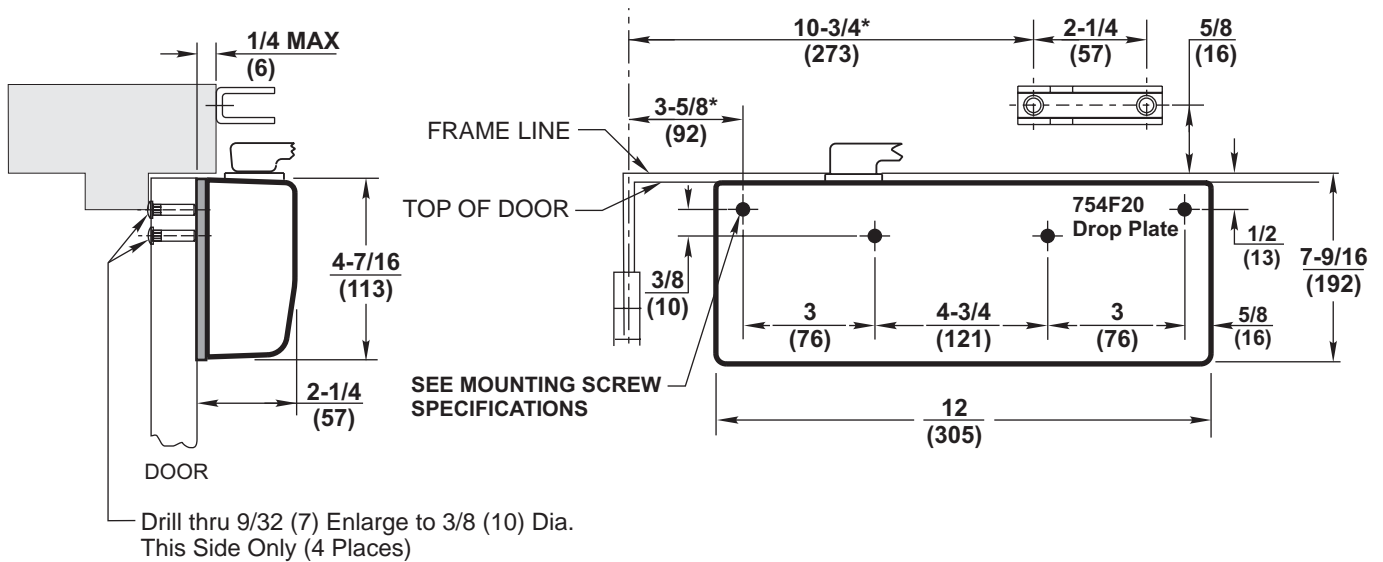

RESPONSIBILITY

Door and Frame Manufacturers are responsible for providing adequate construction or reinforcements for proper installation of hardware shown. All architectural builders hardware must be installed on properly reinforced doors and frames, regardless of the type, material, or method of construction.

DC8200 Series x A10 x 754F20

Heavy Duty Regular Arm Mounted
Surface Door Closer
with 754F20 Drop Plate



ASSA ABLOY

www.corbinrusswin.com

Do Not Scale Drawing

Supersedes _____ Dr. _____ App. _____

Date 04-08 Template Number T31102