

MOUNTING INFORMATION

Sex nuts or through bolts are required for wood and plastic covered composite doors, and any type of door without reinforcements and recommended for wood core and metal clad (Kalamein) type doors.

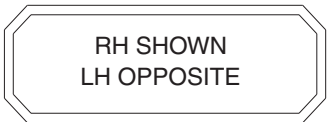

NOTES:

1. Dimensions given in inches and (mm).
2. Minimum Top Rail: 5 (127).
3. To obtain extra closing force, add 3 (76) to dimensions marked by an asterisk (*).
 - This will limit degree of opening to 110° depending on arm adjustment.
 - This setup will not meet ADA.
 - These dimensions apply to the centerline of hinge/pivot for butt hinges, offset pivots, or center pivots.
4. Parallel arm bracket shown is for non hold-open applications. Bracket mounting for hold-open applications has 4 mounting holes.
5. A1 arm cannot be used on fire doors.

CAUTION: Closer To Be Installed In A True Horizontal Position To Ensure Proper Closer Performance.

MOUNTING SCREW SPECIFICATIONS
M83 OFFSET BRACKET & QUIK-INSTALL™ BRACKET

#12-14 self-drilling screw.
1/8 (3) diameter pilot hole } or Sex nuts, furnished required for Wood Applications. } when ordered

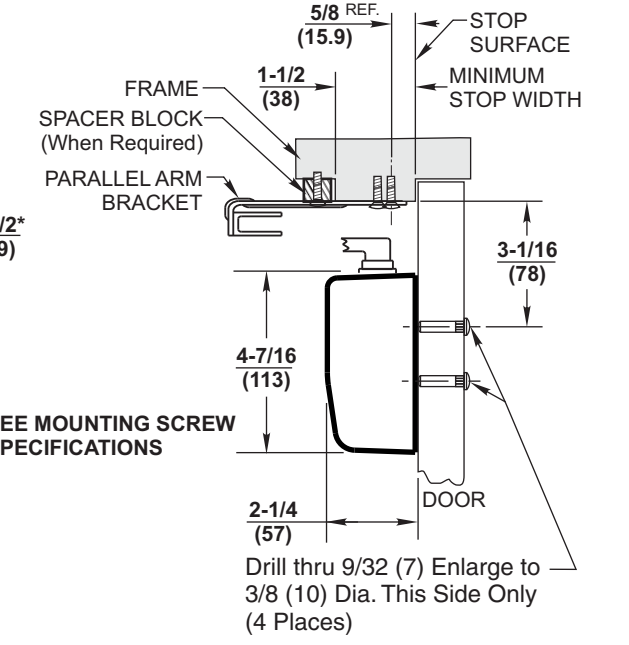
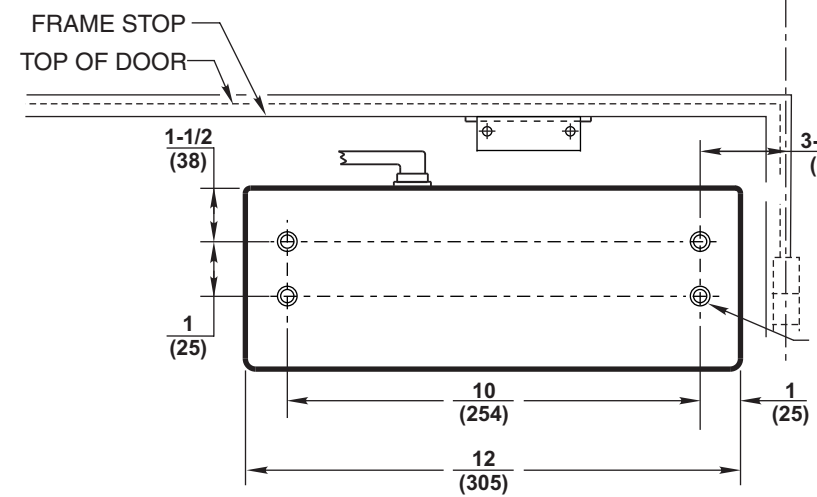
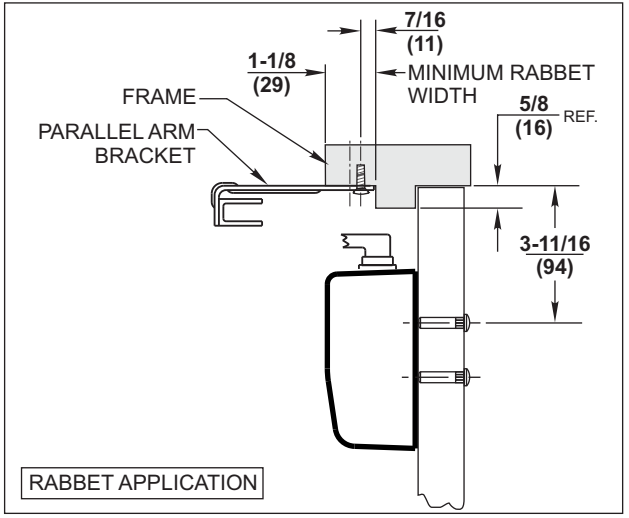
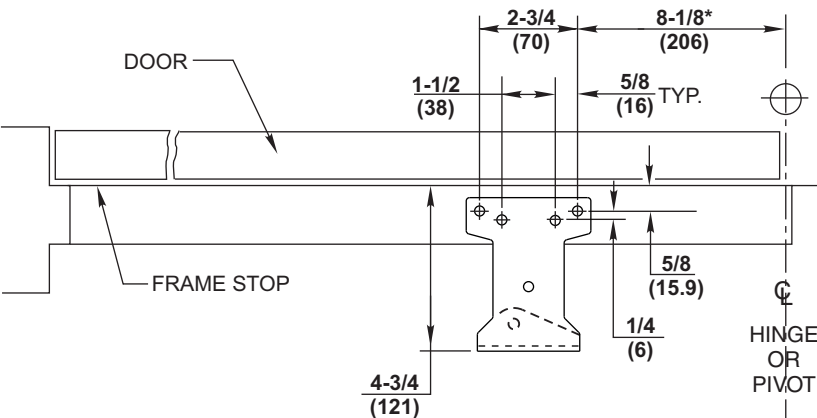
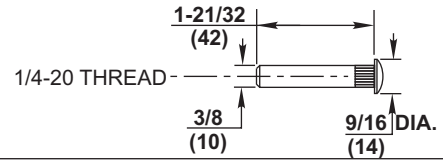

RESPONSIBILITY
Door and Frame Manufacturers are responsible for providing adequate construction or reinforcements for proper installation of hardware shown. All architectural builders hardware must be installed on properly reinforced doors and frames, regardless of the type, material, or method of construction.

DC8210 Series
Surface Door Closer
Parallel Arm Mounting
(with or without A1)

Corbin Russwin
ASSA ABLOY
www.corbinrusswin.com
Do Not Scale Drawing
Supersedes _____ Dr. _____ App. _____
Date 03-11 Template Number T31057