

DC8000 Series Heavy-Duty Door Closer

Keep talking.

We're listening.



Superior Door Control

Heavy-duty, vandal-resistant closer with enhanced features is ideal for a variety of applications.



**Corbin
Russwin** 

An ASSA ABLOY Group company

ASSA ABLOY

DC8000 Series

Heavy-Duty Door Closer

Keep talking. We're listening.

We invite you to add your ideas to our "Team Design Initiatives," an ongoing dialog with our customers and installers that results in better products, better business relationships, and more satisfied customers.



DESCRIPTION Corbin Russwin's DC8000 series door closers offer heavy-duty, vandal-resistant construction with enhanced features and innovative design. With a cast-iron closer body, forged heavy-duty steel arms, and a 1-1/2" piston bore diameter, the DC8000 is ideal for doors where high traffic, abuse and vandalism are common.

APPLICATIONS The DC8000 is perfect for institutional and commercial buildings, retail complexes, hospitals, school or universities. A cover design offering a 2-1/4" projection presents an attractive, streamlined appearance.

COMPLETE ARM OFFERING Closers are tri-packed for regular arm, top jamb or parallel arm mounting, allowing the convenience of one closer to be stocked for a variety of applications. A full compliment of heavy-duty arms are also available, including the Unitrol® by Norton®. The *Unitrol* (formerly the Heavy-Duty Spring Stop), offers the most controlled stop available with a surface door closer.

INSTALLATION The Universal QUIK-INSTALL® bracket guarantees quick and accurate installation. Retrofit plates allow easy replacement for existing door closers without modifying the door prep.

FEATURES

- Cast-iron closer body
- Tri-packed assembly (regular arm, top jamb and parallel arm mounting)
- Non-handed
- Heavy-duty, forged steel arms
- Track applications
- Universal QUIK-INSTALL® mounting bracket
- Retrofit plates
- Multi-sized (adjustable spring sizes 1 through 6)
- Factory sized units (available upon request)
- 1-1/2" piston bore diameter
- 2-1/4" projection
- Captured valves
- Door swings up to 180° (conditions permitting)

CERTIFICATIONS

ANSI/BHMA A156.4, Grade 1 certified
ADA compliant
UL10C and UBC 7-2c

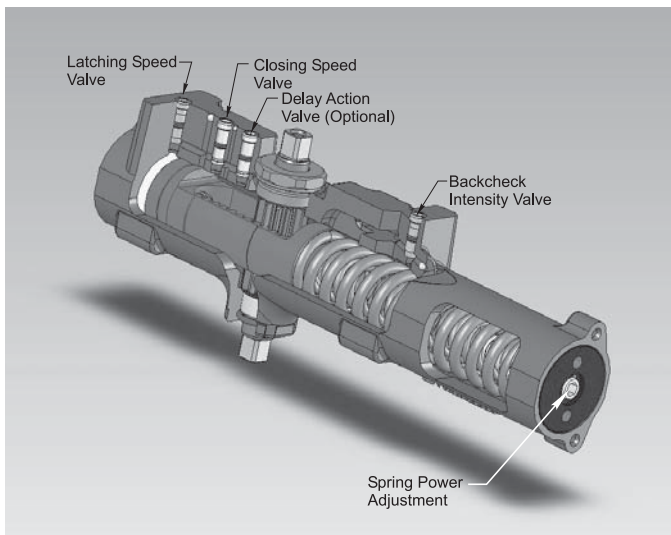
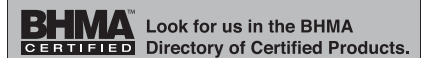
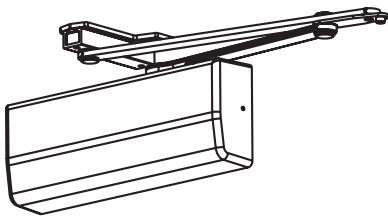

For more information

please contact your local
Door Security Solutions
representative or
visit our website at
www.corbinruswin.com

Security. Innovation. Vandal-resistance.



An ASSA ABLOY Group company

CORBIN RUSSWIN PRODUCTS:

- Pyramid Locking System
- KeyWizard™ Key Control Software
- Access Control Devices
- Electrified Systems Components
- Mortise Locks
- Cylindrical Locks
- Exit Devices
- Door Closers

ASSA ABLOY

45343-9/06N