

DL3000 Series Cylindrical Deadlock

Typical Cylinder and Thumbturn Application

WARNING
This product can expose you to lead which is known to the state of California to cause cancer and birth defects or other reproductive harm. For more information go to www.P65warnings.ca.gov.
08/2018

Locks will fit doors prepped for Fed. 161 Series Cylindrical Lock.

NOTE: When using door silencers or weather stripping, compensation must be made to ensure proper latch and strike engagement.

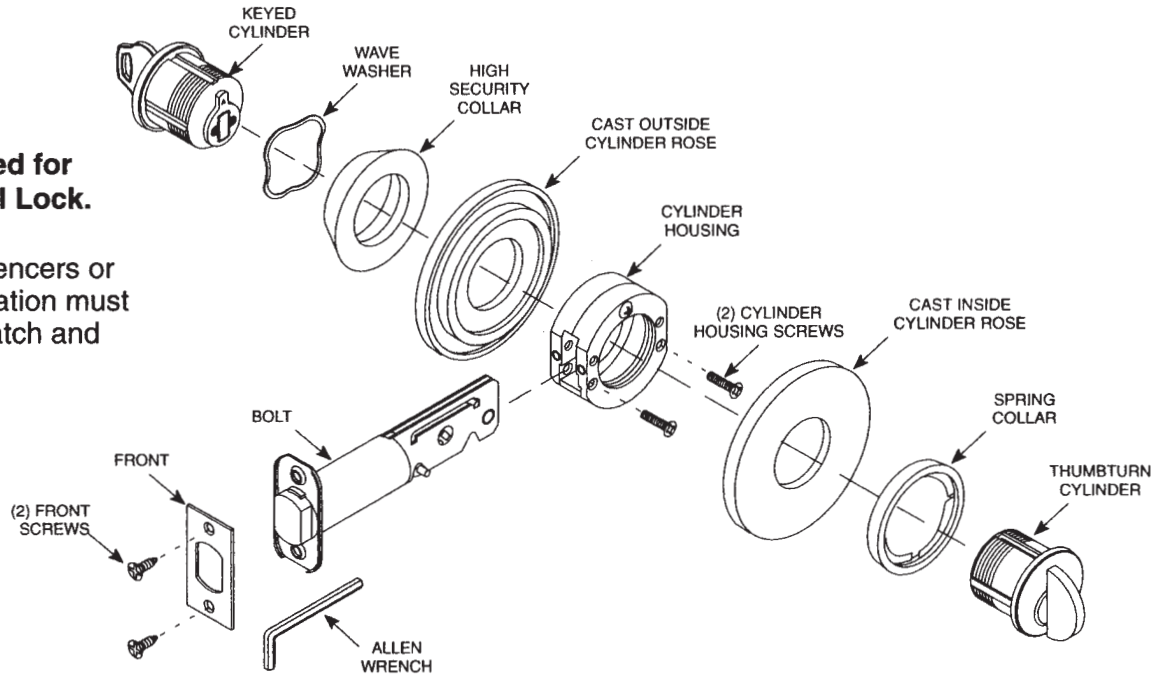

1. Mark Door

Using enclosed template mark door at desired height.

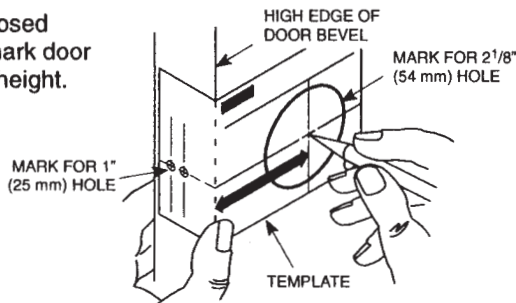

Figure 1

2. Bore Holes and Mortise for Front

- Drill 2 1/8" (54 mm) hole through both sides of door where marked.
- Drill 1" (25 mm) hole in door edge where marked for bolt.
NOTE: 1" (25 mm) bolt hole must be level and perpendicular to the 2 1/8" (54 mm) hole.
- Insert bolt in door and mark outline for bolt front. Mortise edge for bolt front.

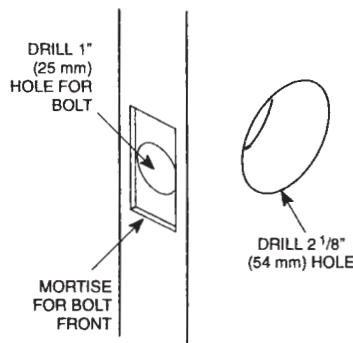

Figure 2

3. Install Cylinder Housing

- Install cylinder housing into 2 1/8" (54 mm) hole.
- Insert bolt into 1" (25 mm) bolt hole and on into cylinder housing.
- Install two (2) cylinder housing screws.

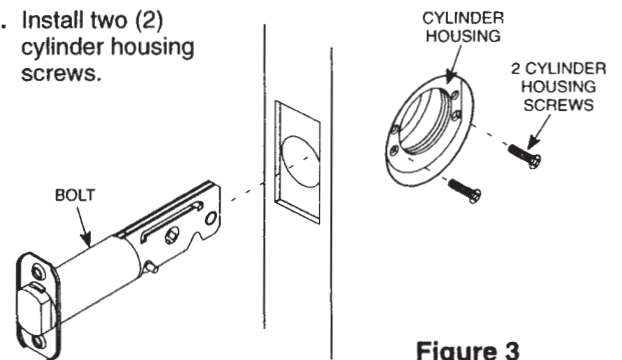

Figure 3

4. Assemble Thumbturn Cylinder and Spring Collar

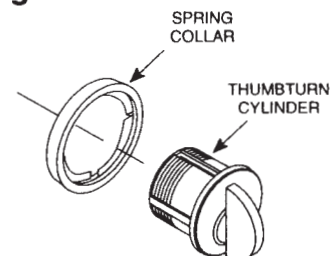

Figure 4

Installation Instructions

DL3000 Series Cylindrical Deadlock

5. Install Thumbturn Cylinder

Caution: Cam must be vertical during installation of the thumbturn cylinder. See Figure 5-1.

Do not use thumbturn as a wrench, or cam will become misaligned and result in malfunction of lock.

- DL3017 ONLY:** Cylinder must be handed before installation. Press small pin firmly into hole in back of cylinder near letter of door hand. For RH and RHR doors, install pin into hole marked R. For LH and LHR doors, install pin into hole marked L. Thumbturn should retract bolt but not project it.
- Holding cylinder rose against door, insert thumbturn cylinder and rotate thumbturn to check for proper operation.
- Insert Allen wrench along side of bolt and tighten cylinder set screw.

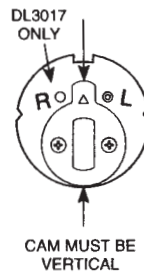

Figure 5-1

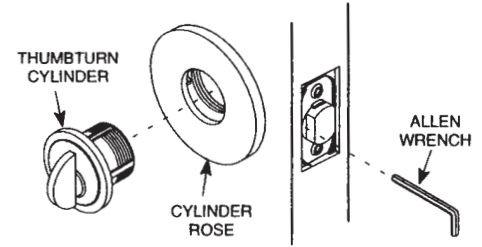

Figure 5-2

6. Assemble Keyed Cylinder, Wave Washer and High Security Collar

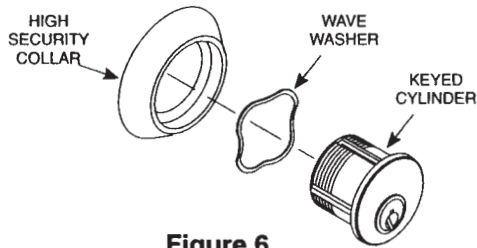

Figure 6

7. Install Keyed Cylinder (Keyed Functions Only)

- See Figure 7-1. Hold cylinder rose against door. Insert key into cylinder. Pull key out one notch and screw cylinder into housing until it stops. (Use key as wrench.)

Note: Reverse rotation of cylinder until key bow is vertical.

- Hold cylinder. Push in key and turn key to operate bolt.
- See Figure 7-2. Make sure cylinder lines up on door as shown.
- Insert Allen wrench along side of bolt until it engages screw and tighten set screw.

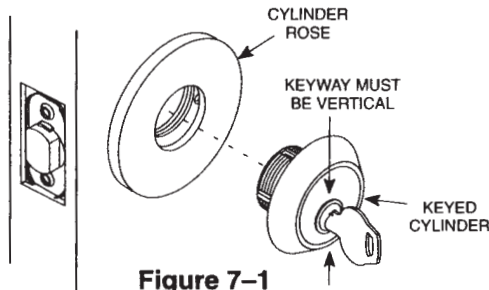

Figure 7-1

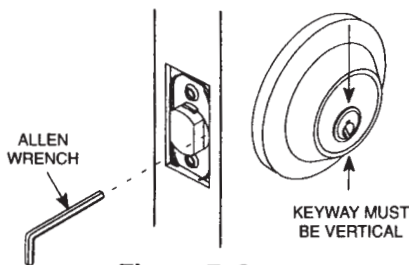

Figure 7-2

8. Install Front

Attach bolt front with two (2) front screws.

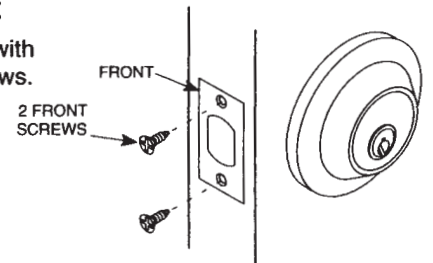

Figure 8

9. Install Box and Strike

- Line up strike with bolt and mark outline of strike. Mortise out to depth required.
- See Figure 9-1. Drill two (2) 1" (25 mm) holes 1" (25 mm) deep in jamb.
- See Figure 9-2. Chisel out for box and attach with two (2) strike screws.

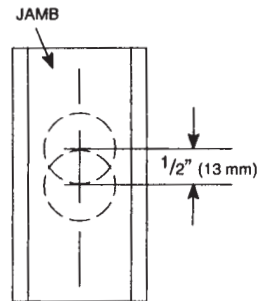

Figure 9-1

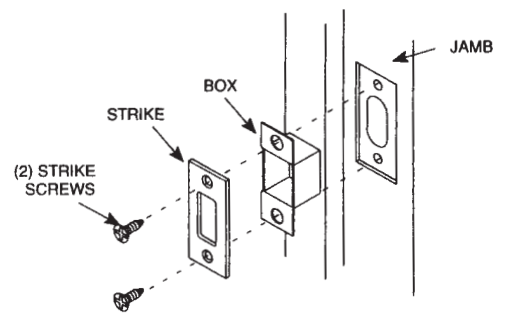

Figure 9-1

**Corbin
Russwin**
ASSA ABLOY

In U.S.:
Corbin Russwin, Inc.
225 Episcopal Road
Berlin, CT 06037 USA
Phone: 800-543-3658

In Canada:
ASSA ABLOY Door Security Solutions Canada
160 Four Valley Drive
Vaughan, Ontario, Canada L4K 4T9
Phone: 800-461-3007

Technical Product Support:
Phone: 888-607-5703