

Delayed Egress

ED4000, ED5000 Series Exit Device

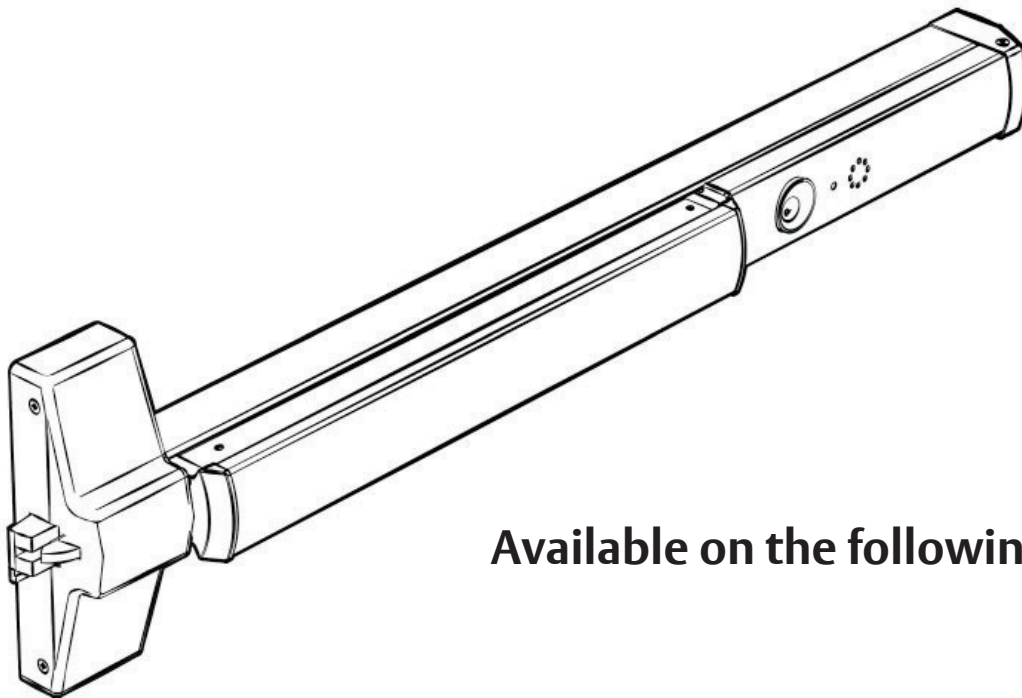

Available on the following devices:

Rim

Mortise

SecureBolt

Concealed Vertical Rod

*Surface Vertical Rod

 **WARNING**

This product can expose you to lead which is known to the state of California to cause cancer and birth defects or other reproductive harm. For more information go to www.P65warnings.ca.gov.

*Rod Guards Required (made by other manufacturers)

TOC	Table of Contents
1	Panic and Fire Rated Devices.....4
a	Checklist4
b	Required Components4
c	Optional Components4
d	Electrical Specifications.....4
2	End Cover and PC Board Assembly5
3	DIP Switch Settings6
4	Installation of End Cover Assembly to Device.....7
5	Device Mounting8
6	Wiring Layout: Input/Output Wiring Descriptions.....9
7	ElectroLynx Connector System for All Electrical Installation..... 10
8	ElectroLynx Wiring Options Overview with QC8 Hinge 11
9	Installing Delayed Egress Exit Device 12
10	ElectroLynx Wiring Options Overview with QC12 Hinge..... 13
11	ElectroLynx Wiring Deed: M93 Trim Monitor Option and QC12 Hinge 14
12	ElectroLynx Wiring Deed: Electrified Trim (ET) Option and QC12 Hinge 15
13	ElectroLynx Wiring Deed: M91 Latchbolt Monitor Option and QC12 Hinge 16
14	Non-ElectroLynx Door Prep..... 17
15	Wiring Diagram: Single Door Exit Only 18

TOC	Table of Contents
16	Wiring Diagram: Single Door with Remote Inputs & Monitoring Outputs 18
17	Wiring Diagram: M93 Trim Monitor Entry with External Door Position Switch .. 19
18	Wiring Diagram: 9903 Electrical Trim Control 20
19	Wiring Diagram: 9905 Electrical Trim Control 20
20	Operating Instructions. 21
21	Additional Options Non ElectroLynx Wiring. 22
22	BOCA 15 Second Delay M89 & BOCA 30 Second Delay M90 22
23	NFPA 101 Requirements: 30 Second Delay M88 Suffix. 22
24	Troubleshooting. 23
25	Appendix: Legacy Boards 25



Caution: Don't change factory applied finishes.

NOTE:

- Wiring method must be in accordance with CSA C22.1, Canadian Electrical Code, Part I, Safety Standard for Electrical Installations, Section 32; and CAN/ULC-S524 Installation of Fire Alarm Systems.

1

Panic and Fire Rated Devices

a

Checklist

1. Check device for shipping damage prior to installation and make sure all parts are on hand.
2. Identify options provided with device.
3. Identify model, type and hand of trim if applicable (see exit device and trim instructions for reversing hands).
4. Contact hardware supplier if device is damaged or missing parts.

b

Required Components (Numbered list correlates with numbers in Figure 1)

1. Delayed Egress Exit Device
2. 24VDC UL Listed Regulated and Filtered Power Supply with Fire Alarm Interface (recommend Securitron BPS 24-1 or 24-2 (UL294 Listed), depending on requirements). Power supply is NOT to be used in UL603 Burglar Alarm System.
3. Power transfer UL or ULC listed (2-10 wire depending on system)-Securitron (EPT) or equivalent.
4. Sign (MUST BE INSTALLED ON DOOR ABOVE DEVICE).

NOTE: The delayed egress system is to be installed in accordance with NFPA 101.

c

Optional Components (Numbered list correlates with numbers in Figure 1)

5. Remote Annunciator
6. Door Position Switch (DPS)
7. Standard Trim
8. Electrified Trim
9. Device and Trim Cylinder

d

Electrical Specifications*

Input Voltage 24VDC (+/-10%)
Wire Size:
18 AWG Min (up to 100')
Signal or Control 22AWG Min
Power Consumption:
Standard Device - 500mA
Device with Safe/Secure Electric Mortise or
Electric Trim Control - 1.5A

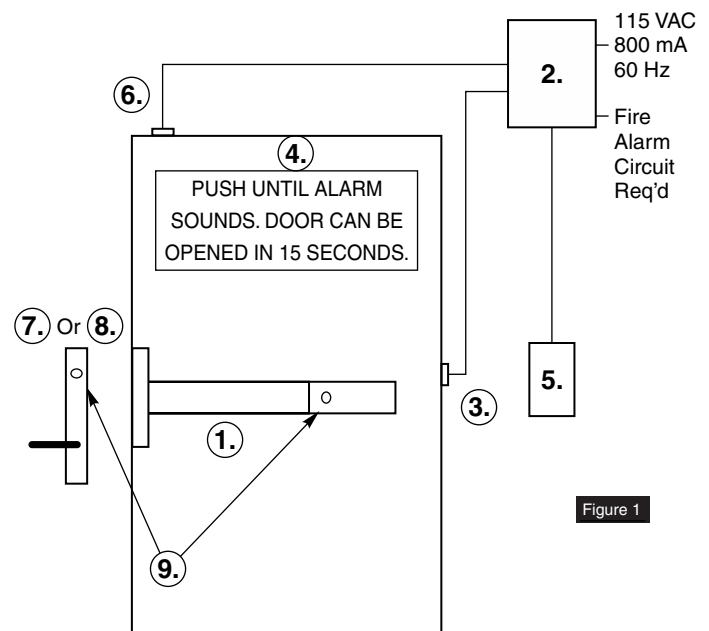

*Follow Local Electrical Codes for Wiring.

NOTE: Components shown do not reflect all possible applications. Consult manufacturer for special applications.

2

End Cover and P.C. Board Assembly

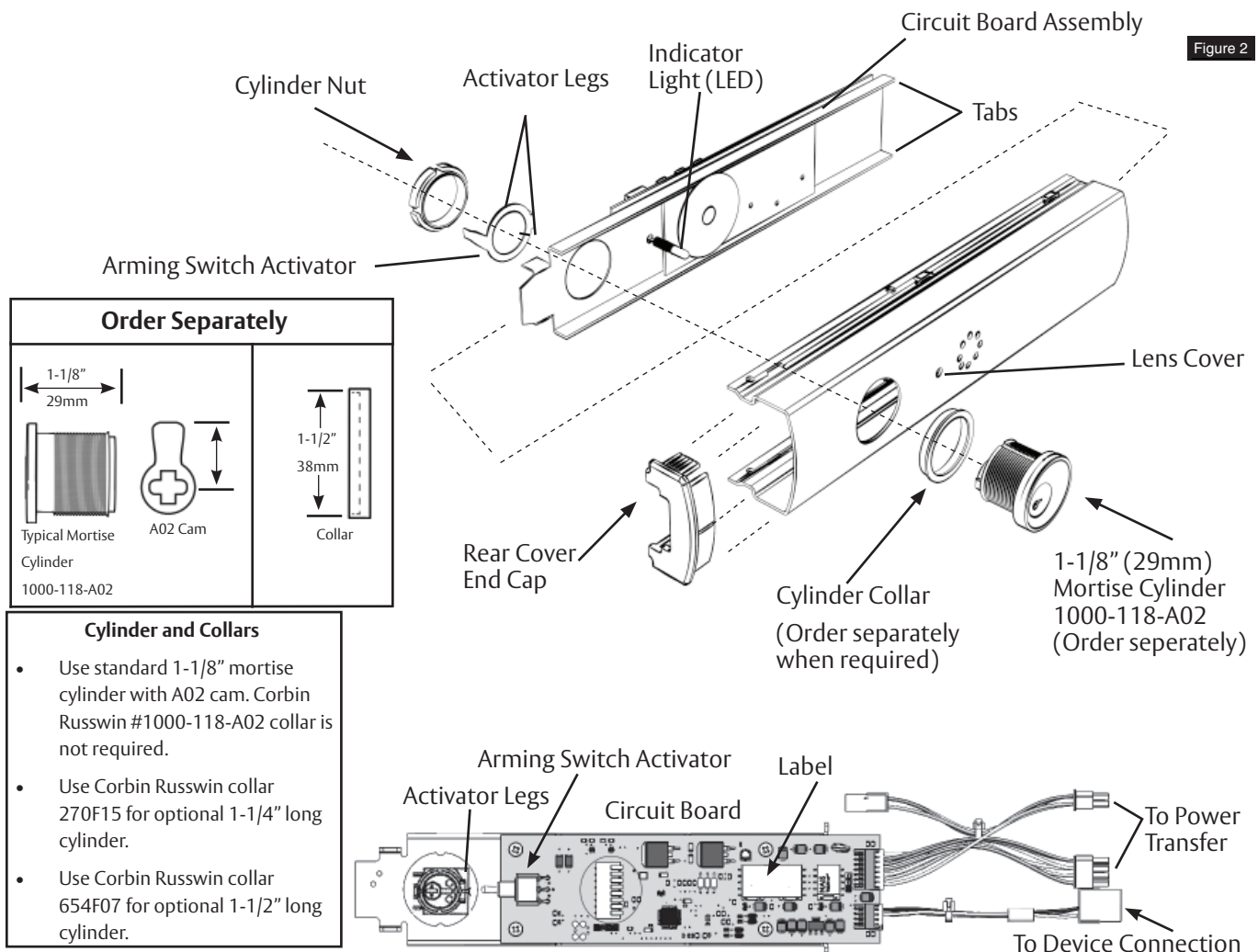

NOTES:

- Factory keyed orders will be shipped assembled.
 - Prior to end cover assembly, device must be cut to proper length to prevent damage to circuit board. 36" Device cannot be field cut. A maximum of 6" can be cut from a 48" device.
1. Slide circuit board assembly into end cover. Front of assembly must be pulled away from cover to prevent damage to LED indicator light. Housing assembly is in correct position when LED can be inserted in lens cover on end cover. (Figure 2)
 2. Insert cylinder (mortise and collar) into end cover with keyway horizontal and toward closest end of end cover.
 3. Slide arming switch activator over cylinder so activator legs are on each side of switch.
 4. Secure parts in place with cylinder nut. Be certain flange on cylinder nut inserts into arming switch activator to allow rotation of activator.
 5. Verify assembly by rotating key counter-clockwise and clockwise. Key should move freely and arming switch should trip for both rotation directions. If key does not rotate freely, verify cylinder nut is in correct orientation. If arming switch does not trip, activator legs on arming switch activator can be bent to reduce or increase rotational travel.

3

DIP Switch Settings

S2-1: Nuisance Audible may be selected ON (default) or OFF.

S2-2 and S2-3: Nuisance Delay time may be selected 0 (Immediate), 1, 2, or 3 (default) seconds.

S2-4 and S2-5: Reset Delay time may be selected 5, 10 (default), 20 or 40 seconds.

S2-6: Whether an external LBM is used for not used for this product, the switch must be set ON (default) to Bypass. S2-6 OFF position is not used.

S2-7: Switch must be set ON (default) to Bypass when an external Door Position Switch (DPS) is NOT used, and OFF when an external DPS is used.

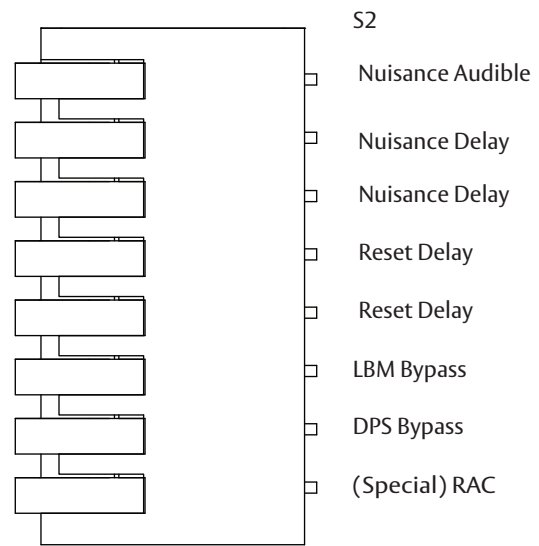

S2 DIP SWITCH - DEFAULT SETTINGS								
S2 DIP SW	1	2	3	4	5	6	7	8
OFF (UP)				OFF				OFF
DOWN (ON)	ON	ON	ON		ON	ON	ON	

PCBA DIP SWITCH VIEW

Nuisance Delay (seconds)				
	0	1	2	3
S2-2	OFF	OFF	ON	ON
S2-3	OFF	ON	OFF	ON
Reset Delay (seconds)				
	5	10	20	40
S2-4	OFF	OFF	ON	ON
S2-5	OFF	ON	OFF	ON

S2-6	OFF	Not used
	ON	LBM Bypass (always set ON)
S2-7	OFF	External DPS is wired to device
	ON	DPS Bypass, external DPS is NOT wired to device
S2-8	OFF	Momentary egress mode 5, 10, 20, or 40sec, device will immediately Rearm After Closing (RAC) door if closed before selected time expires, or will enter alarm mode if time expires with door open. See other details**
	ON	40sec momentary egress mode is extended indefinitely if door is left open, then device immediately Rearms After Closing (RAC) door. See other details*

* S2-8: When an external DPS is used and switch S2-8 ON, and 40 second reset delay (S2-4 and S2-5) are set ON, after activation of momentary egress by cylinder key switch or external remote reset signal, if the Door/DPS is open beyond 40sec the device will remain in momentary egress mode indefinitely and shall not enter alarm mode; then once the Door/DPS is closed it will rearm immediately.

** With S2-8 OFF (S2-4 and S2-5 set for 5, 10, 20 or 40sec), if door/DPS is open after selected time the alarm will sound. Close door to reset and rearm device using cylinder key or remote reset signal.

If door/DPS is opened then closed before selected time expires, the device will rearm immediately.

If DPS is not used, is bypassed with S2-7 ON, the door will rearm immediately after 5, 10, 20 or 40 sec whether the door is open or closed, with either S2-8 ON or OFF.

Ensure eight S2 Dip Switches are set per application before moving on to the next page of instructions.

ED4000, ED5000 Series Exit Device

Installation Instructions

4

Installation of End Cover Assembly to Device

1. Turn end cover assembly over to circuit board side.
2. **Ensure eight S2 Dip Switches are set for application (see previous page).**
3. Slide end cover assembly into device, making sure not to pinch or crimp wires.
4. Connect device lock assembly harness to connector J1. Place wire connectors and excess wire between end cover and P.C. board. (Figure 3, Device End View)
5. Check all connections before proceeding.
6. Proceed to device mounting (see packed instructions).

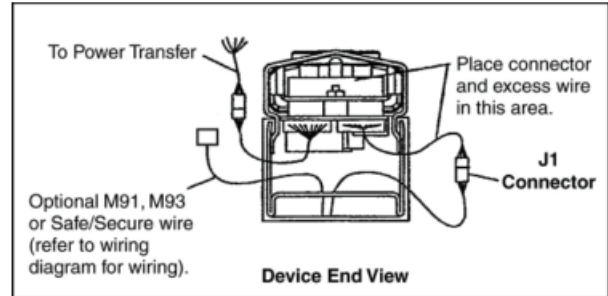
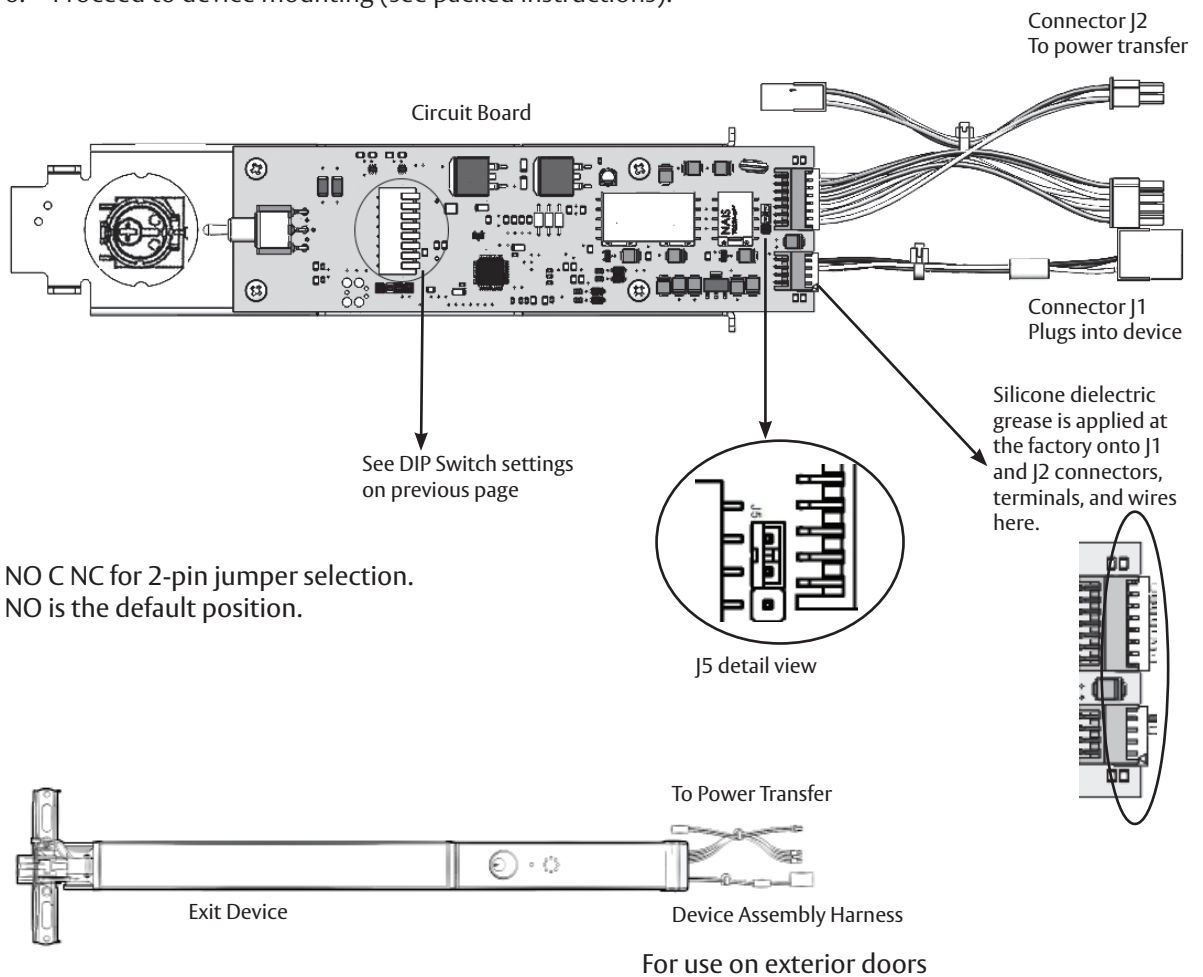

Figure 3



NOTE:

- Review J5 Alarm Relay NO or NC selection above. If NC contact is required, remove PBCA/cover assembly from rail, move 2-pin jumper to NC, then re-install PCBA/cover on rail.

5

Device Mounting

1. Refer to installation instructions included with device and trim for complete door and frame preparations. Refer to template #T30890 for wire access hole location.
2. Feed wires from power transfer through wire access hole in door. (Figure 4)
3. When required, mount outside trim to door (see trim installation instructions).
4. Mount device to door (see device installation instructions).
5. Do not install end cap until device has been wired and tested for operation (See wiring diagrams).
6. Check mechanical operation and proceed to wiring diagrams.

NOTE: Wire nuts can be inserted into wire access hole after making connections. Quick disconnect can be used without removing wire nuts.

NOTE: For QC8 and QC12 ElectroLynx wiring, refer to Sections 8 and 10. ElectroLynx has pluggable connectors, wire nuts are not needed.

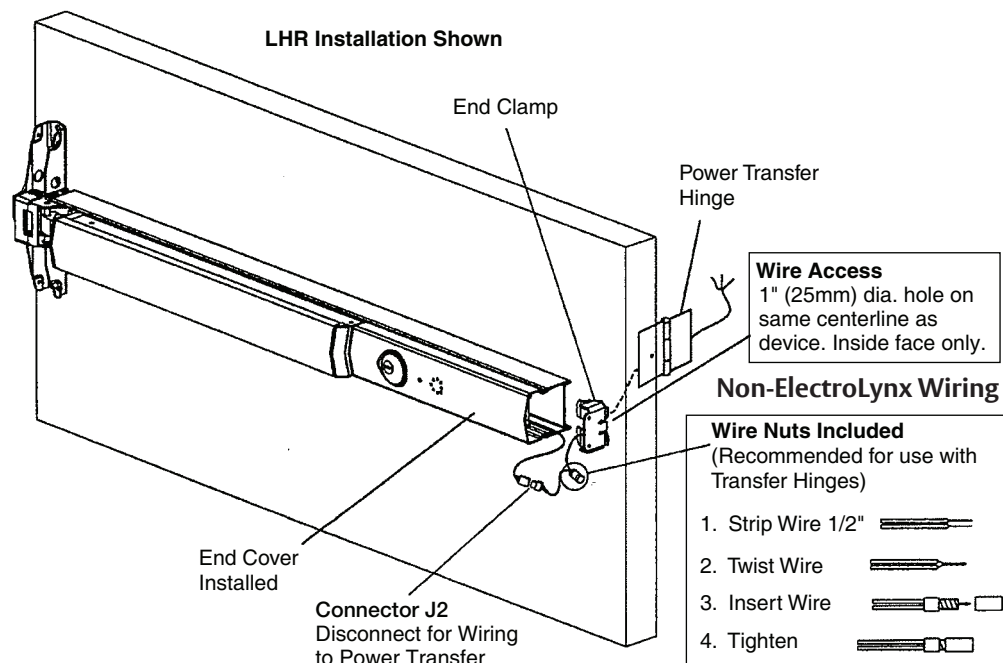

Figure 4

NOTES:

- Wires must be protected from abrasion.
- For use with Class II circuits only.

6

Wiring Layout: Input/Output Wiring Descriptions

J2 Connector
(See Figure 5 on next page)

8-Pin
ElectroLynx
Connector

Pin Number	Input/Output	Wire Color	Description	Pin Number
10	Input	Black	24VDC Power Supply (-Circuit Ground)	1
12	Input	Red	24VDC Power Supply (+Positive)	2
11	Output	White	Secure Relay Output - Normally Open (NO) contact. Power off - contact is open Powered/armed - Relay energizes contact closes. After 15 or 30 seconds delay when device releases, the relay de-energizes, contact opens (same as Power off state).	3
13	Output	Green	Secure Relay Output - Normally Closed (NC) contact. Power off - contact is closed. Powered/armed - Relay energizes, contact opens. After 15 or 30 seconds delay when device releases, relay de-energizes, contact is closed (same as Power off state).	4
NC	EGND	Orange	Earth Ground connection to PCB mounting plate via ring terminal	5
3	Output	Blue	Alarm Relay Output - J5 jumper Selectable NO/NC contact that changes state when alarm cycle has been activated. Default shipped position - jumper is on NO contact setting. Power off - contact is NO or NC as per jumper selection. Powered/armed - Relay energizes contact reverses state. When alarm cycle is activated - Relay de-energizes (same as Power off state).	6
8	Input	Brown	Remote Reset Input - Momentary input from key switch, pushbutton, etc. Will release device for 5, 10, 20, or 40 seconds for egress or ingress and also reset device when in bypass or alarmed state.	7
6	Input	Yellow	Remote Bypass Input - Momentary input from key switch, pushbutton, etc. Will maintain device in an unlocked state for normal device operation. Device must be rearmed by resetting from key switch on device or remote reset.	8

NOTE: ElectroLynx QC8 Hinge is only required if all eight wires are used. When DPS and any other wiring options are on the 4-pin connector, the hinge is NOT required.

NOTE: Secure and Alarm Relay contacts are rated max load 1A @24VDC.

6

Wiring Layout: Input/Output Wiring Descriptions, continued

J2 Connector (See Figure 5 below.)

4-Pin ElectroLynx Connector

Pin Number	Input/Output	Wire Color	Description	Pin Number
NC	Input/Output	Violet	C, LBM or C, Trim Mon. or ET(-)	1
NC	Input/Output	Gray	NO, LBM or NO, Trim Mon. or ET(+)	2
NC	Input/Output	Pink	NC, LBM or NC, Trim Mon.	3
2	Input	Tan	Door Position Switch Input-Input sense for DPS switch option	4

NOTE: ElectroLynx QC12 Hinge is required if DPS and/or any options shown are required.

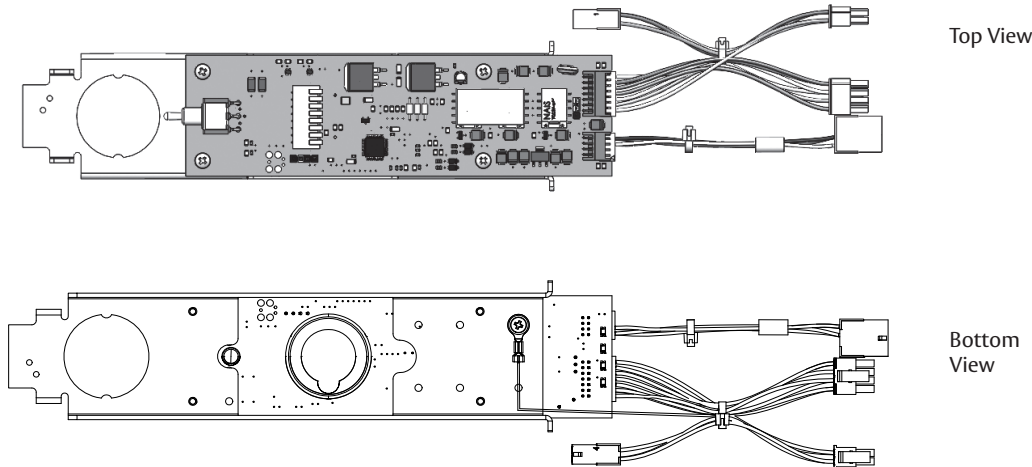

Figure 5

NOTE: Refer to Section 25 if replacing legacy PCBA/wiring with new PCBA/wiring.

7

ElectroLynx Connector System for All Electrical Installation

1. Mount exit device per instruction sheet provided.
2. Plug exit device connector into raceway connector in door. Feed through 1" (25mm) hole in door. Install rail mounting end clamp bracket with two (2) screws supplied. Install end cap.
3. Plug raceway connector from edge of door into electric hinge connector and feed wires back through door prep. Mount electric hinge to door.
 - A. If wiring now, wire frame side wires, to wires on pigtail harness, on hinge as required by using connectors allowed by local code. Plug pigtail harness connector into electric hinge connector. Feed harness through frame prep and mount electric hinge.
 - B. If wiring later, plug pigtail harness connector into electric hinge connector. Feed harness through frame prep and mount electric hinge.

7

ElectroLynx Connector System for All Electrical Installation, continued

Installation Notes:

1. Wiring to pigtail harness is per facility wiring requirement.
2. For an ElectroLynx system, go to function or monitor page(s) with your device.
3. Combinations of certain monitors can be used in each device. These instructions detail installation of each monitor separately.

ElectroLynx Connector System Notes:

System is designed to be installation friendly, with plug connectors from electric hinge through door to device. The only wiring required is loose wires on pigtail harness assembly on frame side of electric hinge (included with QC Hinge). Combinations of certain switches and monitors can be used.

The plug and receptacle connectors are designed to mate and lock together. Plug connectors into each other with locking mechanism aligned. Do NOT force connectors together any other way.

8

ElectroLynx Wiring Options Overview with QC8 Hinge

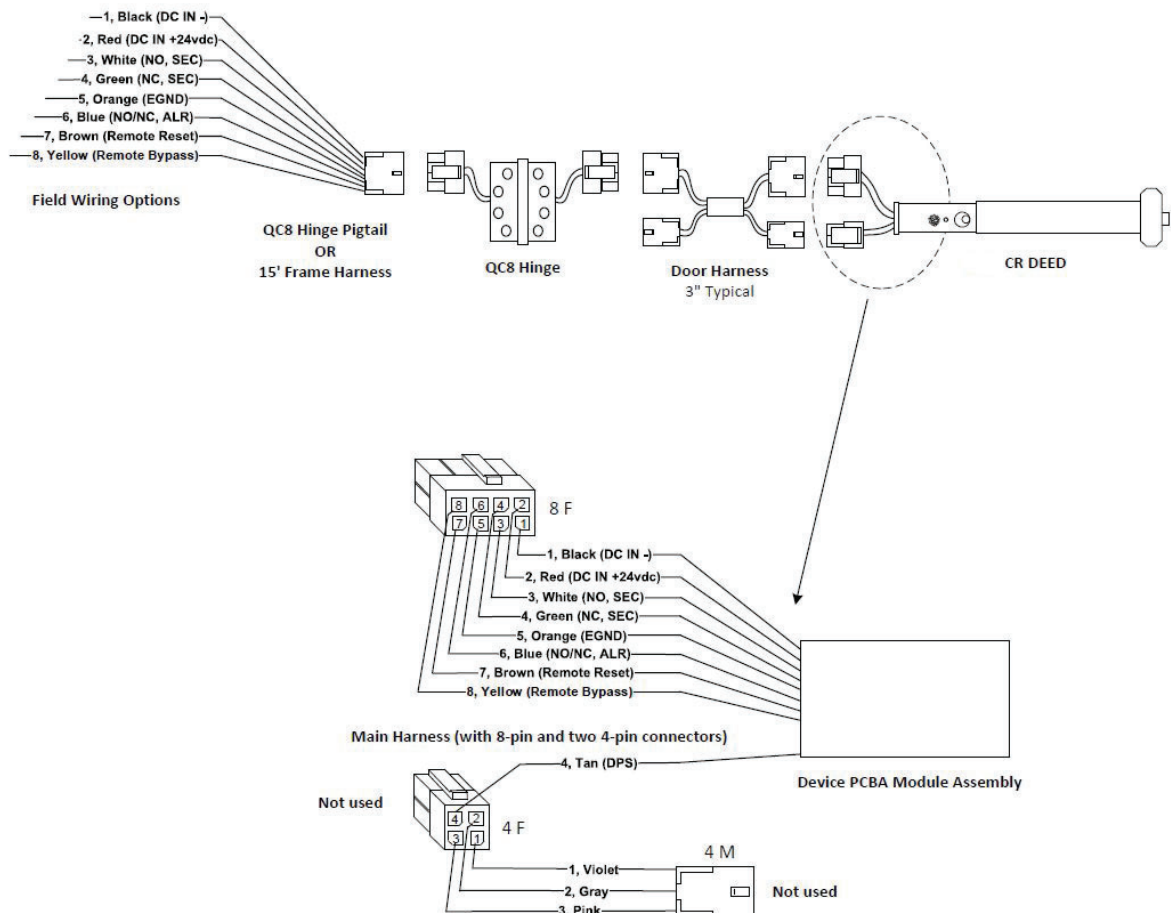

9

Installing Delayed Egress Exit Device

Refer to Figure 6 for delayed egress exit device installation wiring.

NOTE: For ElectroLynx Hinge Connector System: Follow Section 6 wiring instructions.

For non-ElectroLynx door:

Remove connector at end of exit device and connect to incoming wires from power source using wire nuts, butt splices, etc. See Section 14 for hole locations and sizes.

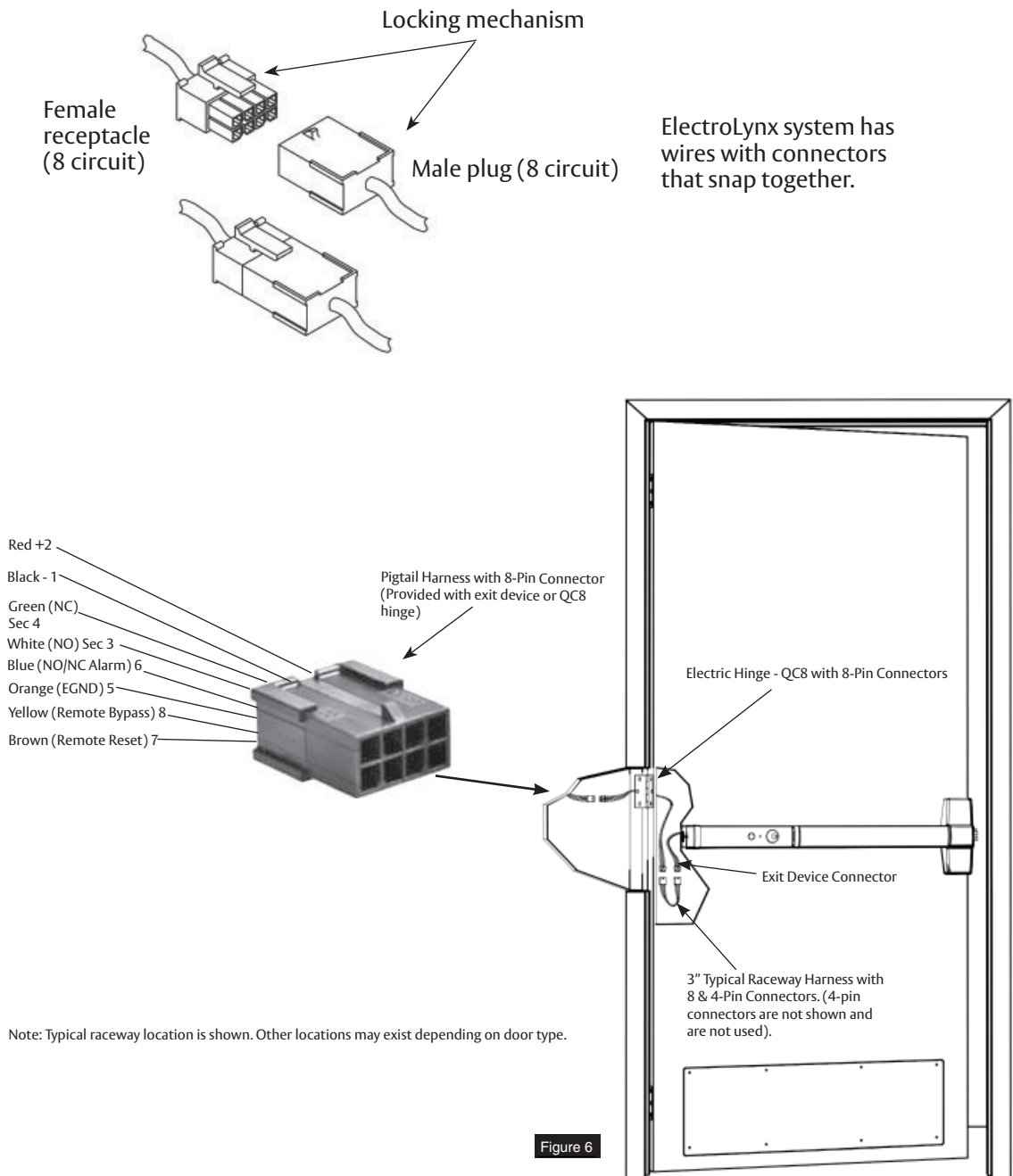

10

ElectroLynx Wiring Options Overview with QC12 Hinge

Refer to Figure 7 for M93 Monitor - Trim Actuated SPDT Switch wiring.

NOTE:

- Switch wiring max load: 2A @28VDC.
- Wire must be protected from abrasion.
- For use with Class II circuits only.
- For ElectroLynx QC12 Hinge Connector System: Follow Sections 11, 12, and 13 wiring instructions.
- For non-ElectroLynx door:
Remove connector at end of exit device and connect to incoming wires from power source using wire nuts, butt splices, etc. See Section 14 for hole locations and sizes.

Note:

New wiring shown. Items followed by * indicate NEW PCBA wiring OR NEW DEVICE wiring that differs from Legacy wiring. Pluggable 4-pin connections from Device Harness to Main Harness is for new QC12 hinge wiring method.

QC12 Hinge - Wiring Options

Wiring to 8-pin and 4-pin connectors are REQUIRED (12 wires max)
- If external DPS wiring is REQUIRED (Set PCBA Dip Switch S2-7 OFF)
- If LBM, Trim Monitor, OR Electrified Trim Options are REQUIRED.

After routing two wires from ET through the chassis and the wire channel in back of rail then Install Molex Female 4-pin connector (supplied) onto pre-crimped female terminals onto Black wire pin 4-1, Red wire pin 4-2

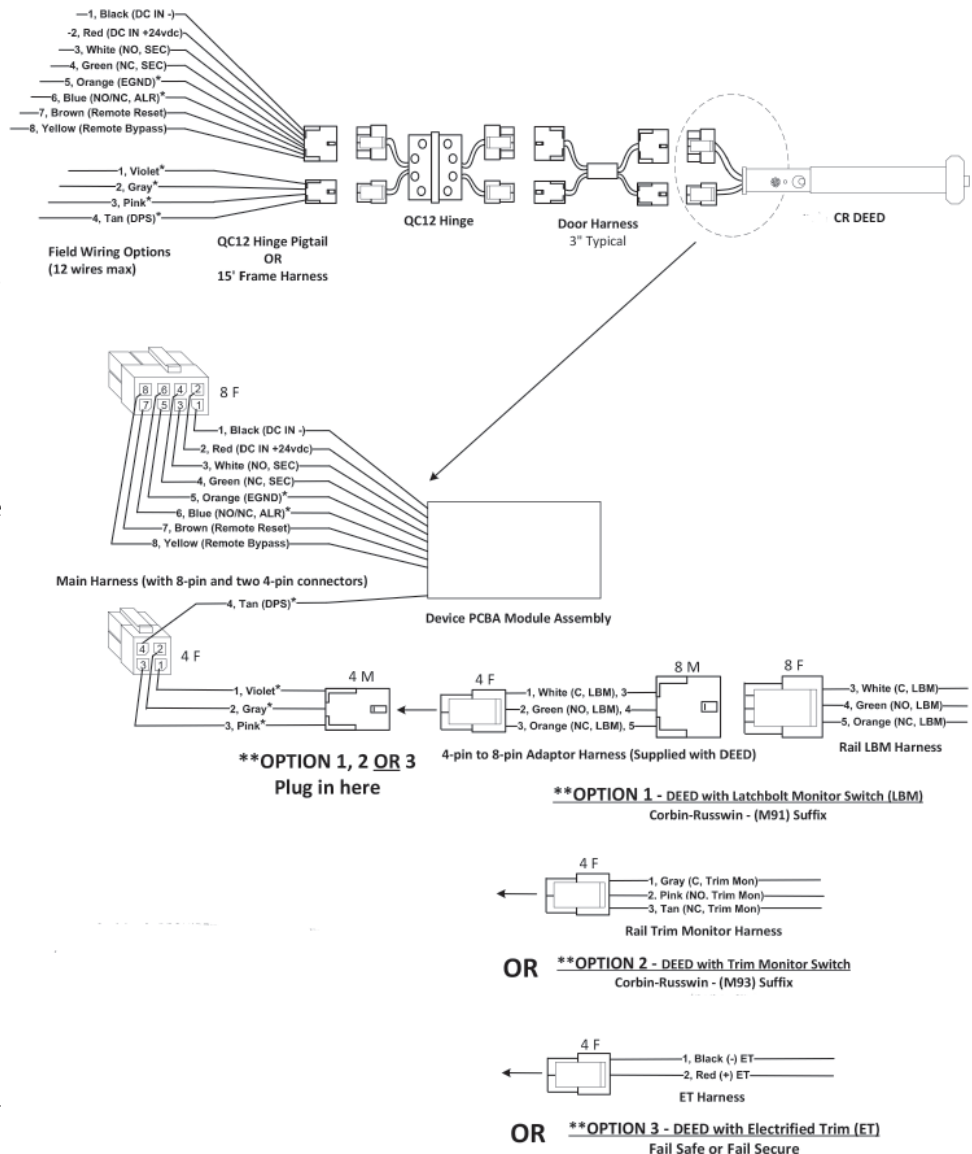

Figure 7

Delayed Egress

ED4000, ED5000 Series Exit Device

Installation Instructions



11

ElectroLynx Wiring Deed with M93 Trim Monitor Option and QC12 Hinge

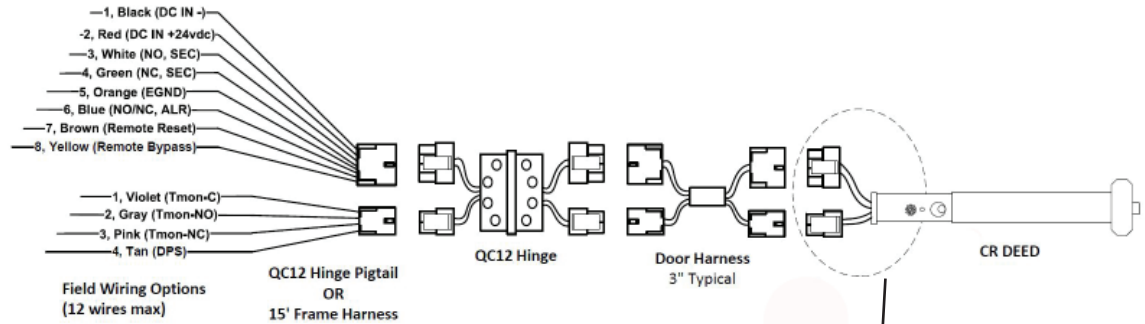

QC12 Hinge - Field Wiring Options

Wiring to 8-pin and 4-pin connectors is **REQUIRED** (12 wires max).

- If external DPS wiring is **NOT REQUIRED**, set PCBA Dip Switch S2-7 **ON**.
- If external DPS wiring is **REQUIRED**, set PCBA Dip Switch S2-7 **OFF**.

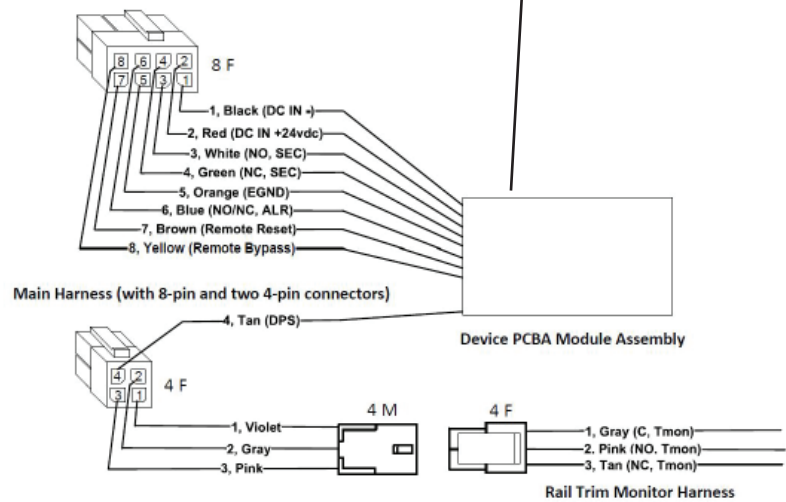

Supplied with DEED when ordered with M93 Trim Monitor (Tmon) Option

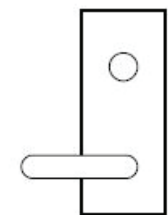
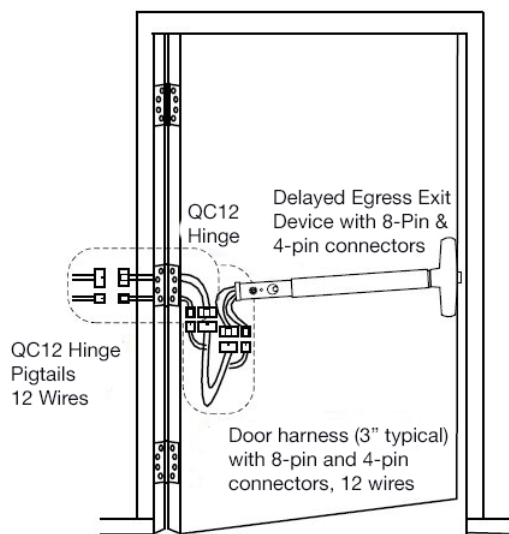

Mechanical Trim

Note: Typical raceway location shown.
Other locations may exist depending on door type.

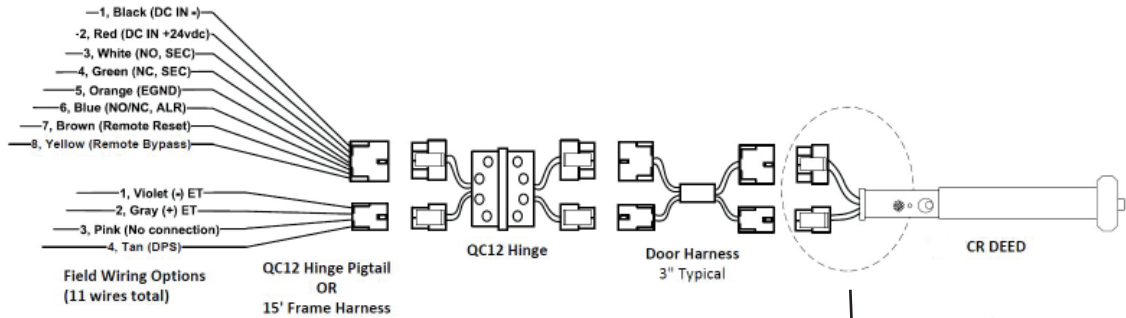

QC12 Hinge - Field Wiring Options

Wiring to 8-pin and 4-pin connectors is **REQUIRED** (12 wires max).

- If external DPS wiring is **NOT REQUIRED**, set PCBA Dip Switch S2-7 **ON**.
- If external DPS wiring is **REQUIRED**, set PCBA Dip Switch S2-7 **OFF**.

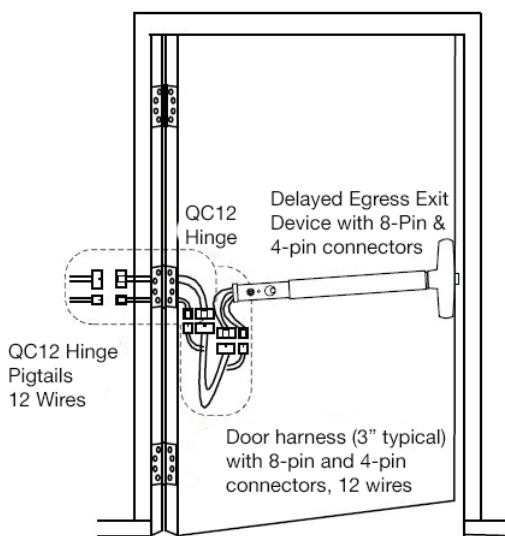
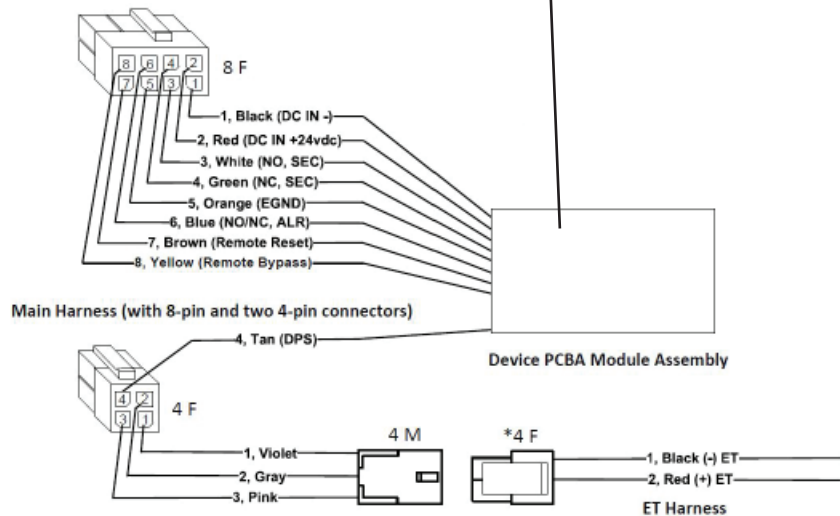

Supplied with DEED when ordered Fail Safe or Fail Secure Electrified Trim (ET)

*Requires field to route two wires from ET through the chassis and the wire channel in back of rail then install loose Molex Female 4-pin (*4F) connector (supplied) onto pre-crimped female terminals onto Black wire pin 4-1, Red wire pin 4-2.

- 9903 Electrified Trim (ET) (SAF)
Fail Safe
- Or
- 9905 Electrified Trim (ET) (SEC)
Fail Secure

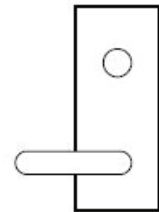

Note: Typical raceway location shown.
Other locations may exist depending on door type.

Delayed Egress

ED4000, ED5000 Series Exit Device

Installation Instructions



ASSA ABLOY

13

ElectroLynx Wiring Deed with M91 Latchbolt Monitor Option and QC12 Hinge

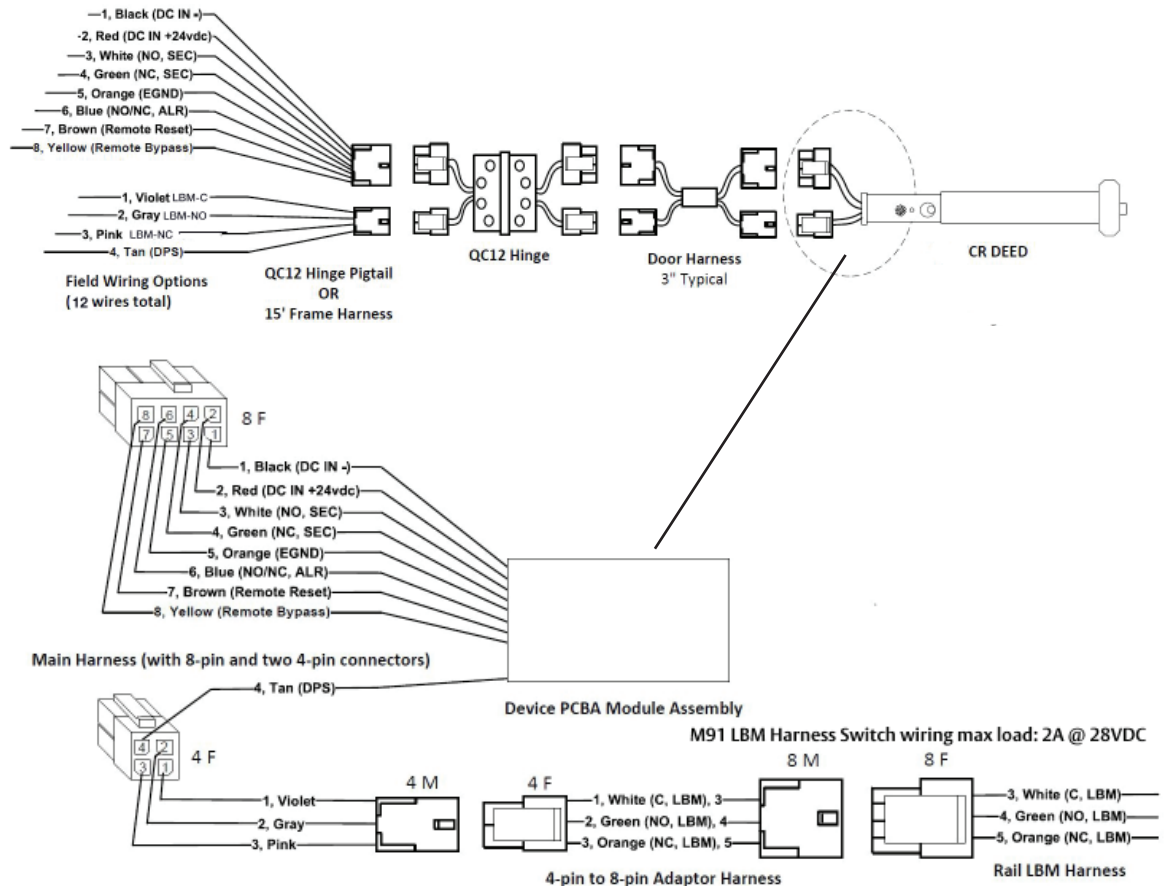

Supplied with DEED when ordered with M91 (LBM) Option

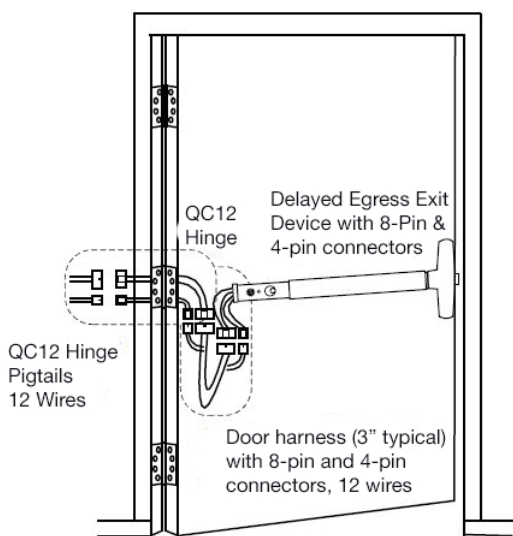

QC12 Hinge - Field Wiring Options
Wiring to 8-pin and 4-pin connectors is **REQUIRED** (12 wires max).

- If external DPS wiring is **NOT REQUIRED**, set PCBA Dip Switch S2-7 **ON**.
- If external DPS wiring is **REQUIRED**, set PCBA Dip Switch S2-7 **OFF**.

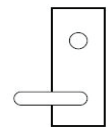

Mechanical Trim

Note: Typical raceway location shown.
Other locations may exist depending on door type.

ED4000, ED5000 Series Exit Device

Installation Instructions

14

Non-ElectroLynx Door Prep

Refer to Figure 8 for non-ElectroLynx Door preparation.

NOTE:

- Do not scale drawing.
- Dimensions are in inches (") and millimeters (mm).
- LHR H.M. opening shown. Details are typical for all opening materials (both hands).
- This preparation is an addition to preparation shown on device template.
- See device template to locate centerline.
- Shields for wiring access recommended for insulated and composite doors.
- Locate and prepare wiring access holes when installing device.

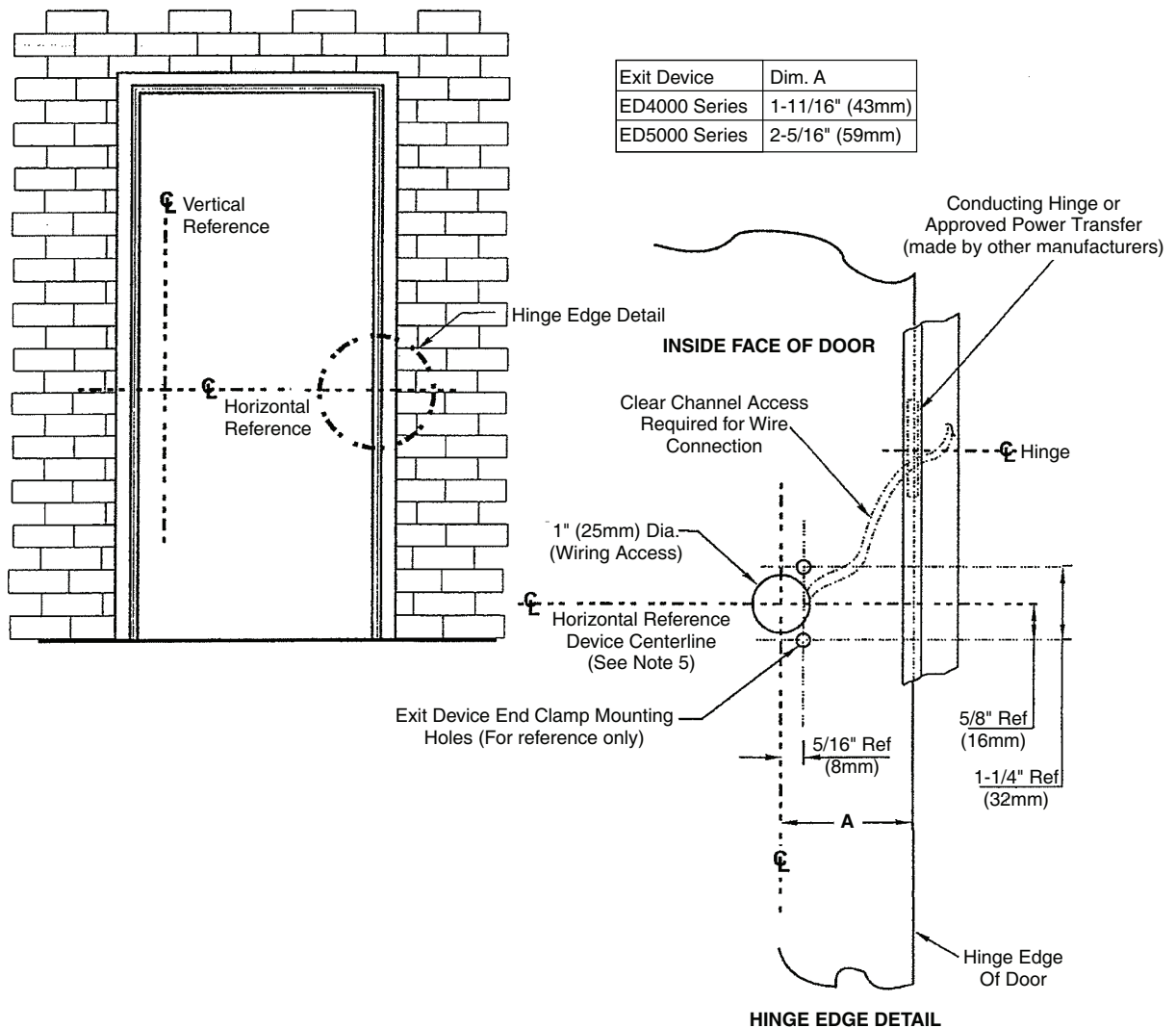

Figure 8

15 Wiring Diagram - Single Door Exit Only

Operation:

Mechanical trim can be added for entry. Ingress by trim without touching device push bar rim will not affect alarm if a door position switch is not being used. Refer to DPS wiring if necessary.

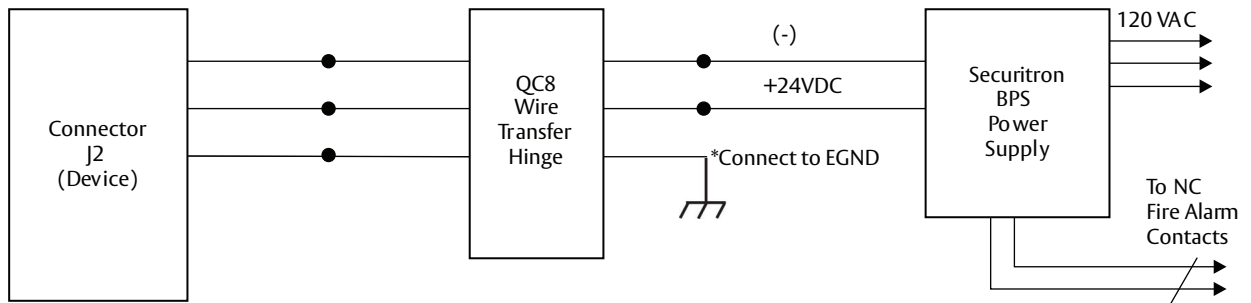

Figure 9

16 Wiring Diagram - Single Door With Remote Inputs & Monitoring Outputs

Operation:

Monitoring: Red LED indicates device is armed and secure. Activating device will sound alarm. (Figure 10)
Green LED will illuminate after 15 seconds. Device will release for exit (unsecure).

NOTE: If dry contacts are needed for signaling or monitoring, a 24VDC relay is recommended.

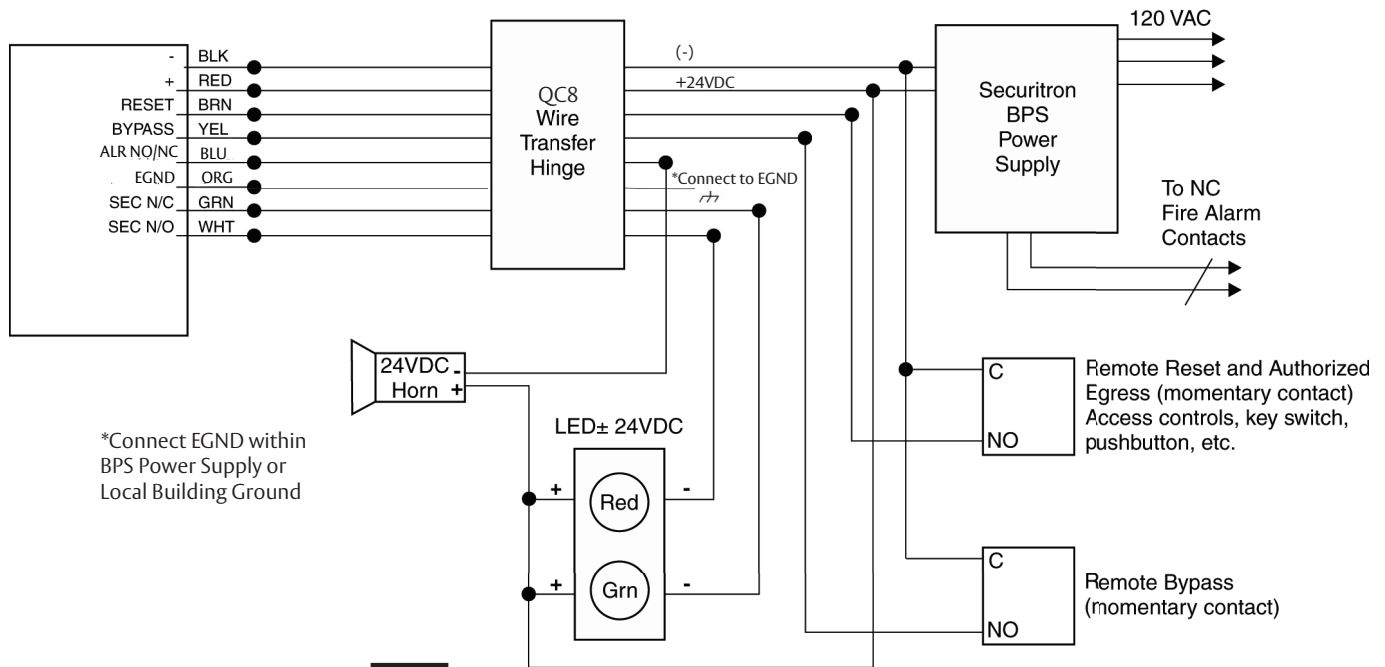

Figure 10

*Connect EGND within BPS Power Supply or Local Building Ground

17

Wiring Diagram - M93 Trim Monitor Entry with External Door Position Switch

* Door Position Switch (DPS) made by other manufacturers.

Operation:

Door Position Switch (DPS)* is used to activate alarm when door has been forced open. It also prevents device from being armed when door is propped open.

M93 trim monitor switch, when activated, will bypass unit and allow entry. Unit must be manually reset for rearming with cylinder key. (Figure 11)

NOTE: Requires M93 trim monitor switch on device for alarm shunting.

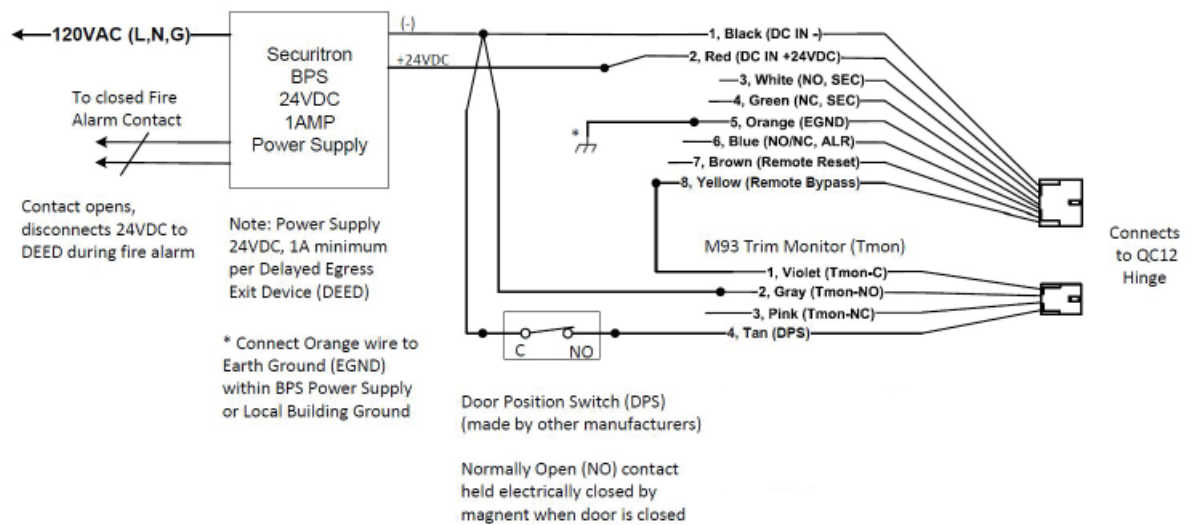

Figure 11

18

Wiring Diagram - 9903 Electric Trim Control

Operation:

Fail Secure (SAF) Trim allows normal access control for entry, and also allows entry during power failure or fire alarm activation. (Figure 12)

Electric trim operation will not affect armed device.

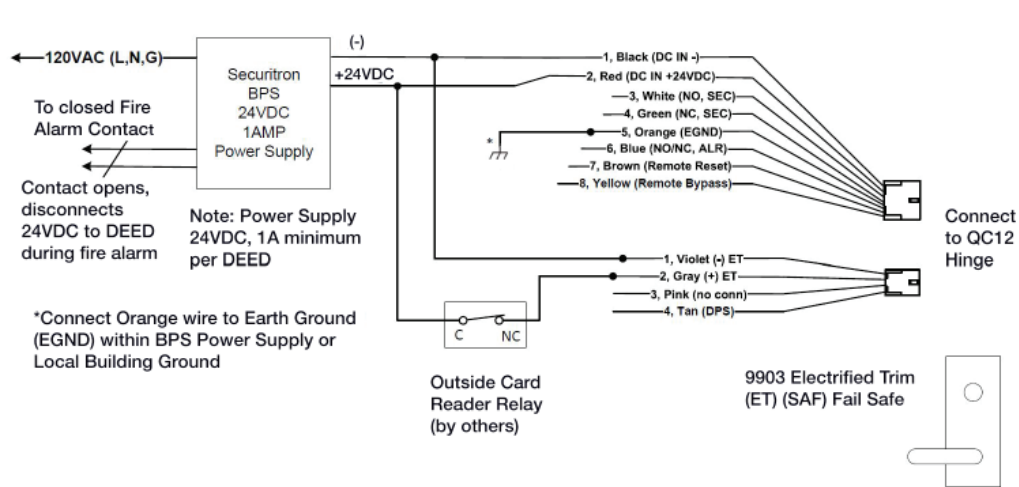

Figure 12

19

Wiring Diagram - 9905 Electric Trim Control

Operation:

Fail Secure (SEC) Trim allows access control for entry. Outside trim will remain locked during power failure or fire alarm activation. (Figure 13)

Electric trim operation will not affect armed device.

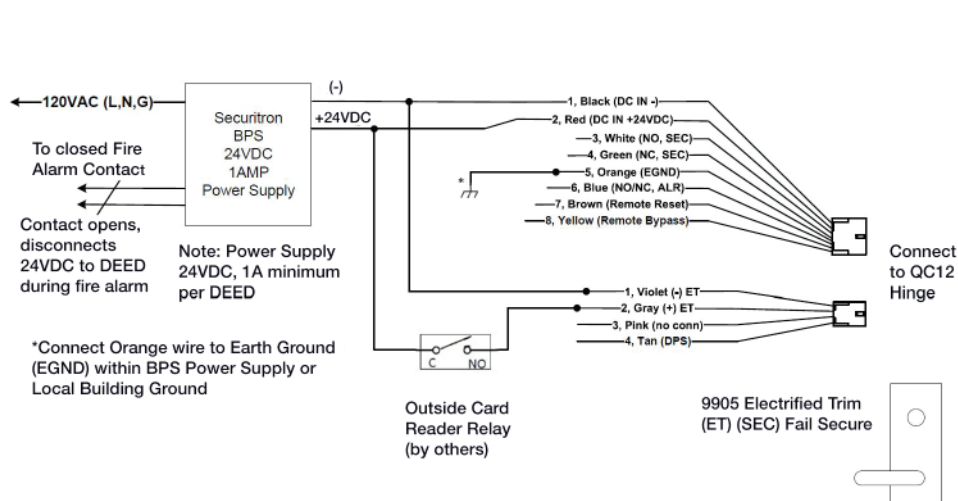

Figure 13

There are three (3) modes of operation (Figure 14):

- Delayed Egress
- Momentary Egress
- Bypass (Maintained) Egress

Delayed Egress Mode

1. Apply power to device. The initialization / self test sequence is as follows:

- Cover LED is RED for 2 seconds with horn sounding for 500ms.
- Cover LED is then GREEN for 2 seconds, followed by AMBER for 1 second with the 4 diagnostic LEDs illuminated.
- Cover LED is RED and green diagnostic LED is illuminated. The device is now armed, which will not allow pushpad to retract latchbolt for immediate egress.

2. If the device is not functioning, refer to the Troubleshooting Guide.

Momentary Egress Mode (Figure 14)

1. With device armed, rotate key counter clockwise and return to center position (remove key).
2. Red LED will flash quickly, approximately two times every second. Device will release for momentary egress for 10 seconds (factory set). 5, 10, 20 or 40 second reset delay may be selected using DIP switch positions 4 and 5.
3. After the reset delay time has elapsed, or if the cylinder key is rotated a second time counter clockwise during a reset delay, the device shall re-arm. When an external DPS is used and door is opened and closed during momentary egress, the selected reset delay shall be canceled and the device shall re-arm.
4. Device will now be back in delayed egress mode.

Bypass (Maintained) Egress Mode (Figure 14)

1. Rotate key clockwise, return key to center position and remove.
2. Red LED will flash slowly (one time every four seconds).
3. Device is disarmed, acting as a standard exit device which allows free egress.

Resetting device from Bypass Mode to Delayed Egress Mode (Figure 14)

1. Rotate key counter clockwise, return to center position and remove.
2. Solid red LED will illuminate.
3. Device will be in delayed egress mode.

Delayed Egress Operation When Armed

Exit door is normally closed and latched. Delayed Egress device secures door in locked mode with solid red LED indicating locked mode status. Depressing pushpad for three (3) seconds or less will sound device nuisance beeps, twice every 1.2 seconds without initiating alarm. Depressing pushpad longer than three (3) seconds will initiate an irreversible local audible alarm with a continuous tone, and a visual amber indicator. After delay time (15 or 30 seconds), device releases, LED changes to green, and the local audible alarm remains as a continuous tone until reset by keyswitch. Remote monitoring contact outputs can be used to alert security personnel. Person depressing pushpad is denied egress for 15 or 30 seconds (depending upon setup) and security personnel are alerted.

NOTE: 30 seconds may be accepted by local jurisdiction.

Figure 14

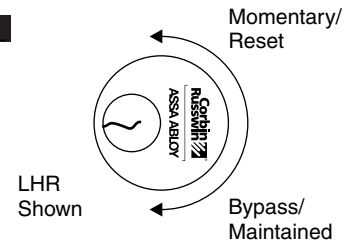

20

Operating Instructions, continued

Re-arm After Closing for Indefinite Delay

With 40 second momentary egress setting (S2-4 ON & S2-5 ON), S2-8 ON, and an external DPS is wired to the PCBA-after activation of momentary egress by cylinder key switch or external remote reset signal, if the Door/DPS is open beyond 40 seconds, it will remain in momentary egress mode indefinitely and shall not enter alarm mode. Then once the Door/DPS is closed, it will re-arm immediately. With (S2-4 ON & S2-5 ON) S2-8 OFF for same scenario as above, the device will enter alarm mode after 40 seconds if the Door/DPS is still open. If Door/DPS is closed before 40 seconds, it will re-arm immediately.

21

Additional Options Non ElectroLynx Wiring

Electrically Controlled Trim (Mortise Device) “Safe/Secure”

The Delayed Egress Exit Device is available with Fail Safe (SAF) or Fail Secure (SEC) outside trim operation. In a fire condition, the Fail Safe trim will release for entry. When Access control is used, the Fail Secure trim allows entry by means of a remote card reader, keyswitch, push button, etc.

Note: If a Door Position Switch is not used, the trim will open the door without affecting the device in an armed condition (refer to wiring diagrams for wiring).

This option is used when outside trim is desired to be used with an external Door Position Switch (by others). This switch will allow bypass (disarms device) when the trim is used for ingress. The device will need to be reset upon entry by means of the keyswitch on the device or a remote SPDT switch (refer to wiring diagrams for wiring).

Note: If an external DPS is not used, Standard trim and Safe/Secure trim will allow entry without affecting the device in an armed mode. The device will only be affected when the push pad is depressed. Latchbolt monitor switch is a SPDT switch that monitors security of latchbolt or vertical rods.

Figure 15

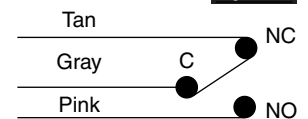

Outside Trim Monitor Switch
(M93) Suffix

Figure 16

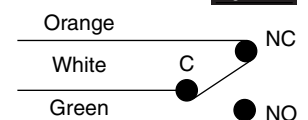

Latchbolt Monitor Switch
(M91) Suffix

22

BOCA 15 Second Delay M89 and BOCA 30 Second Delay M90

Upon depressing the pushpad for 1 second or longer, the device will sound an audible continuous tone and allow the door to be opened within 15 (or 30) seconds. The alarm will remain as a continuous tone until reset. Resetting of the alarm and re-arming of the device occurs automatically once the door has been returned to the closed position for 30 seconds. The 30-second re-arming timer will re-start if the pushpad is depressed or the door is re-opened before actual re-arming of the device occurs. A DPS (Door Position Switch) is required for the BOCA option.

NOTE: BOCA option is not suitable for installations in accordance with NFPA 101.

23

NFPA 101 Requirements: 30 Second Delay M88 Suffix

Upon depressing the pushpad for 3 seconds or longer, the device will sound an audible continuous tone and allow the door to be opened after 30 seconds. The alarm will remain as a continuous tone until reset. Resetting of the alarm and re-arming of the device is accomplished by manual means only.

Problem	Solution
Power is applied, but unit will not arm (No red LED).	<ul style="list-style-type: none">• Check all connections on circuit board and wire harness.• Check for power 24VDC at power inputs (-black) and (+red) and check polarity.• Check wire transfer for any bad connections or broken wires.• Check power output at power supply.• Must be 24VDC regulated.
Device alarms continuously when power is applied.	<ul style="list-style-type: none">• Check trigger mechanism wire harness on circuit board and all other connections.• Check pushpad activating switch in device.
Units with Door Position Switch (made by other manufacturers).	<ul style="list-style-type: none">• Make sure DPS is wired (electrically closed - with door closed) into wire harness. Make sure DPS is working properly by using a meter to check continuity when door is opened and closed.
Device allows mechanical latchbolt retraction with power applied and LED shows armed.	<ul style="list-style-type: none">• Check for correct power, 24VDC regulated.• Check for correct amperage on power supply (must be rated equal or greater than device, 500mA minimum).
Exit device latchbolt/rods will not latch properly.	<ul style="list-style-type: none">• Refer to standard exit device installation instructions troubleshooting guide.

NOTE: If device is not working properly after troubleshooting, contact your local hardware distributor or local Corbin Russwin representative, or contact Corbin Russwin.

Refer to the following table and notes for an explanation of each LED's function.

Diagonistic LEDs	Function
Yellow	ON - LBM Bypass DIP switch position 7 is OFF-set ON OFF- LBM Bypass DIP switch position is ON (normal operation)
Red (Push Rail Switch)	ON- Rail Push Bar is depressed. OFF- Rail Push Bar is released.
Orange (Door Status Switch)	ON- Door Status Switch is open. Door is open/violated. OFF- Door Status Switch is closed or DPS Bypass DIP switch position 6 is ON.
Green (Solenoid)	ON- Rail Solenoid is energized. (+24 VDC from main board) OFF- Rail Solenoid is de-energized.

NOTES:

1. When the rail is armed (in Delayed Egress Mode) and the door is closed and latched, the **Red End Cover LED** and the **Green Diagnostic LED** should be ON only. All other LEDs should be OFF.
2. With the rail armed, depressing the rail push bar slightly will turn the **Red Diagnostic LED** ON. The rail should go into alarm immediately (no nuisance delay) or after being pressed for 1, 2, or 3-second nuisance delay setting. The rail will be in the irreversible alarm mode - End Cover LED is Amber with local audible beeping tone. After a standard delay of 15 seconds (Or 30-second optional delay), the rail solenoid de-energizes and passage is allowed. End cover LED is green with alarm at a steady tone which continues until reset by key switch.
3. When a Door Status switch is used and the door is opened, the **Orange Diagnostic LED** will turn ON, which indicates that the door is not closed. When not using a door status switch, DIP switch position 7 must be set to ON, Orange Diagnostic LED shall be off.

Diagnostic LEDs

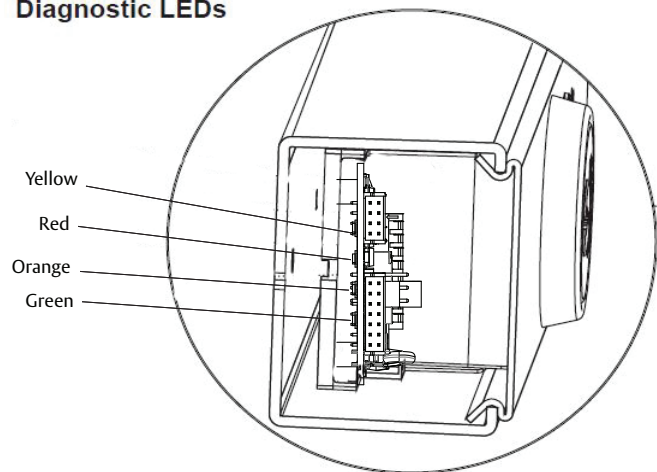

There were two versions of legacy printed circuit boards where the wire colors, alarm, and secure relay connections differed. Please refer to the below diagrams as a reference, if needed.

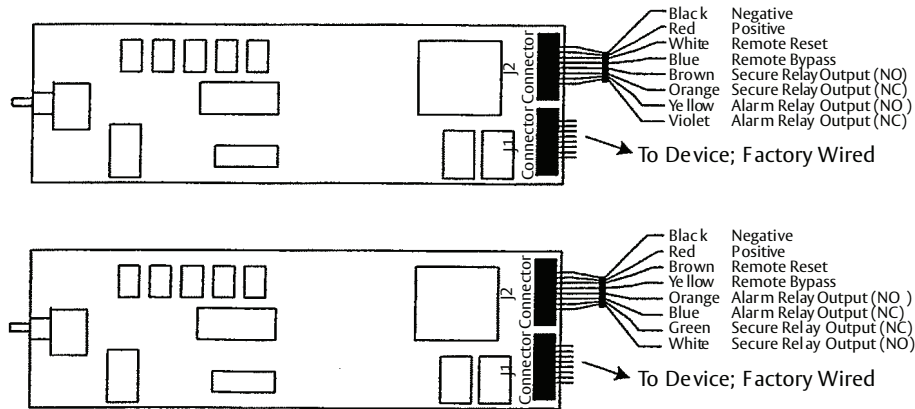

Delayed Egress

ED4000, ED5000 Series Exit Device

Installation Instructions



ASSA ABLOY

Delayed Egress

ED4000, ED5000 Series Exit Device Installation Instructions



The ASSA ABLOY Group is the global leader in access solutions. Every day, we help billions of people experience a more open world.

ASSA ABLOY Opening Solutions leads the development within door openings and products for access solutions in homes, businesses and institutions. Our offering includes doors, door and window hardware, locks, access control and service.



Corbin Russwin
225 Episcopal Road
Berlin, CT 06037
Phone: 800-543-3658

Experience a safer
and more open world