

Strike Reinforcement
(See Note 6)

Notes:

1. Do not scale drawing.
2. Dimensions are in inches (mm).
3. LHR door shown. Preparation is typical for both door hands.
4. Minimum door stile width: 3-1/2(89).
5. Prepare mounting holes when installing the device.
6. Unreinforced frames require blind rivet nuts (by others) to mount the strike.
7. Dimension from door face.
8. For recommended door reinforcements see template T30800. Unreinforced doors require SNB option to mount the device components and strike interlock.
9. Holes for optional SNB: 9/32 (7.00) dia. inside door face;
3/8 (9.50) dia. outside door face.
10. Provide door stiffeners as needed to prevent door collapse due to installation with power tools, door use, or abuse.
11. Device mount to hinge stile (not shown) requires hole location and preparation during device installation.
12. For outside trim preparation see appropriate trim template.
13. For electrical devices (suffixes M91, M92, M93, M94, M97) also see template T30890.
14. This hole MUST be field located using physical part as template after installation is complete and device is fully operational.

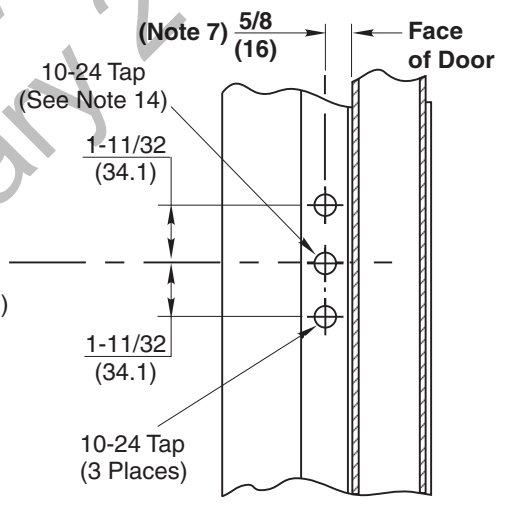
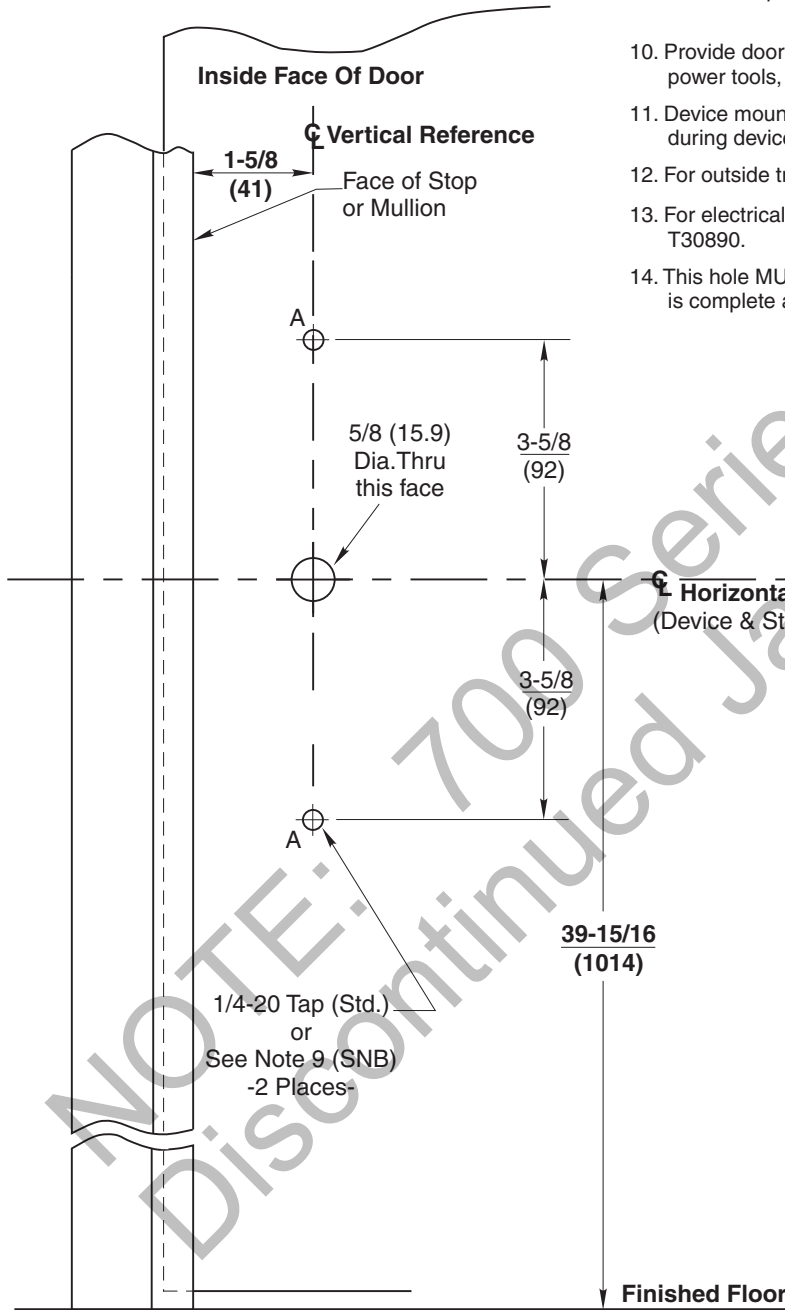

Strike Preparation Details

FRAME TEMPLATE	MULLION		
	SERIES	SIZE	ILLUSTRATION
T30882	700 Series	1-1/2" x 3" (38 x 76)	Doors ← 1-1/2" Mullion Width
T31074	900 Series	2" x 3" (51 x 76)	Doors ← 2" Mullion Width
T31075	FE700 Series WS700 Series		

CAUTION: Width of mullion used with exit device will affect device backset. Determine Mullion Series and Width before prepping doors for exit devices.

ED4200M Rim Panic Devices
for Narrow Escutcheon Trim with 650F308 Strike Standard
Application for Metal Door and Frame or Mullion
(Not for Fire Labeled Devices)



SUPERSEDES	DO NOT SCALE DRAWING
TEMPLATE NUMBER	DATE
T31159	05-09

ASSA ABLOY, the global leader in door opening solutions
Copyright© 2009 Corbin Russwin, Inc. All rights reserved.
Reproduction in whole or in part without the express written permission of Corbin Russwin, Inc. is prohibited.